

ELSZ 60S Extended Carriage

Call 800-321-7800 or visit us online at www.nookindustries.com to configure and order your ELSZ 60S Extended Carriage today!

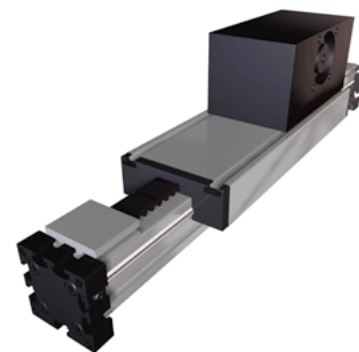
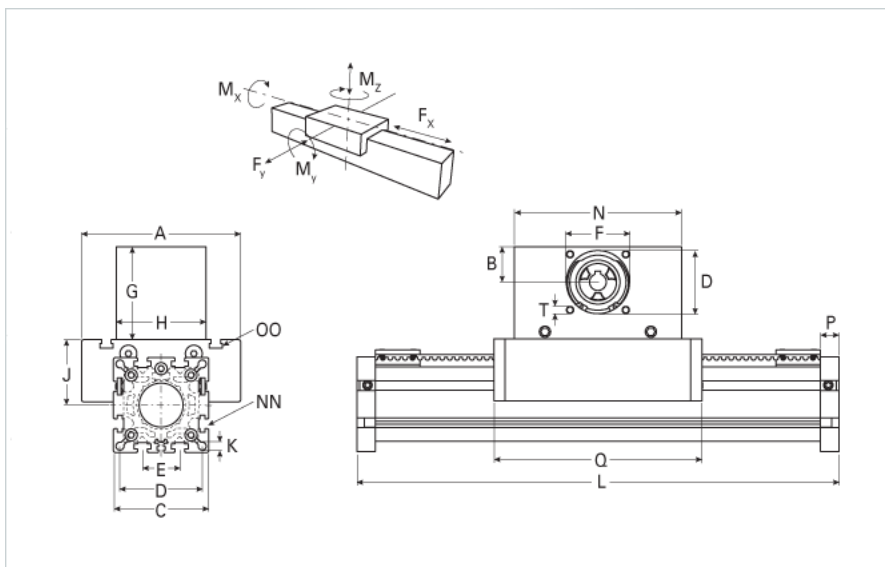

Details

| | |
|-----------------|------|
| Size | 60S |
| Belt | 5M25 |
| mm/Rev | 130 |
| Number of Teeth | 26 |

Dimensions

| | |
|--------------------------------|---------|
| Basic Length L [mm] | 431 |
| A [mm] | 170 |
| B [mm] | 30 |
| C [mm] | 82 |
| D [mm] | 47 |
| E [mm] | 30 |
| F [mm] | 42 |
| G [mm] | 80 |
| H [mm] | 80 |
| I [mm] | - |
| J [mm] | 53 |
| K [mm] | 8.5 |
| MM | - |
| N [mm] | 130 |
| NN | M8 |
| O [mm] | 69 |
| OO | M8 |
| P [mm] | 16 |
| Q [mm] | 329 |
| T | M6 |
| V [mm] | - |
| Shaft Diameter and Length [mm] | 14 x 35 |
| Key | 5x5x28 |

Speed

| | |
|---------------------|---|
| Speed Maximum [m/s] | 7 |
|---------------------|---|

Forces and Torques

| | |
|-----------------------------|------|
| No-load torque [Nm] | 0.9 |
| Tensile force 0.2 sec [N] | 1000 |
| Tensile force permanent [N] | 900 |
| Fx dynamic [N] | 800 |
| Fy dynamic [N] | 3100 |
| Fz dynamic [N] | 1600 |
| Mx dynamic [Nm] | 65 |
| My dynamic [Nm] | 140 |
| Mz dynamic [Nm] | 170 |
| Fx static [N] | 894 |
| Fy static [N] | 4100 |
| Fz static [N] | 2160 |
| Mx static [Nm] | 88 |
| My static [Nm] | 190 |
| Mz static [Nm] | 230 |

Geometrical moments of inertia of aluminum profile

| | |
|--|----------|
| Elastic modulus [N/mm ²] | 70000 |
| Ix [mm ⁴] | 679000 |
| Iy [mm ⁴] | 697000 |
| Weight | |
| Additional Weight per 100 mm [kg] | 0.62 |
| Basic Weight [kg] | 6.1 |
| Values for Calculating Inertias | |
| Pulley Material - Drive Pulley (x1) | Steel |
| Pulley Material - Idler Pulleys (x2) | Aluminum |
| Pulley Diameter [mm] | 41.38 |
| Effective Pulley Width [mm] | 80 |
| Belt Weight [kg/m] | 0.123 |
| Standard Carriage Weight [kg] | 3.88 |
| No-load torque [Nm] | 0.9 |
| Friction Coefficient | 0.01 |