

## Type 5K, End Code 40

Call 800-321-7800 or visit us online at [www.nookindustries.com](http://www.nookindustries.com) to configure and order your Type 5K, End Code 40 today!

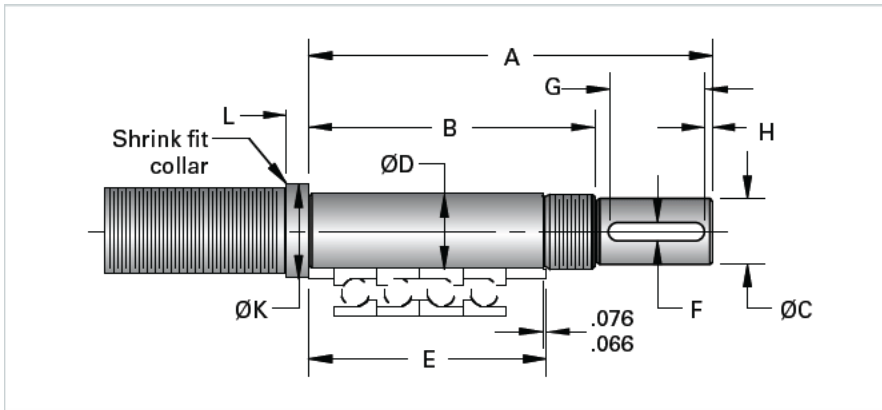

### Product Info

Nominal Bearing Journal Size [mm] 40

### Dimensions

|                |            |
|----------------|------------|
| A [mm]         | 216        |
| B [mm]         | 153        |
| C Maximum [mm] | 35         |
| C Minimum [mm] | 34.97      |
| D Maximum [mm] | 40.011     |
| D Minimum [mm] | 44.995     |
| E [mm]         | 127        |
| F [mm]         | 10         |
| G [mm]         | 51         |
| H [mm]         | 4          |
| K [mm]         | 50         |
| L [mm]         | 12         |
| Lock Nut       | SFZ 40X1.5 |