

P R E C I S I O N L I N E A R A C T U A T O R S

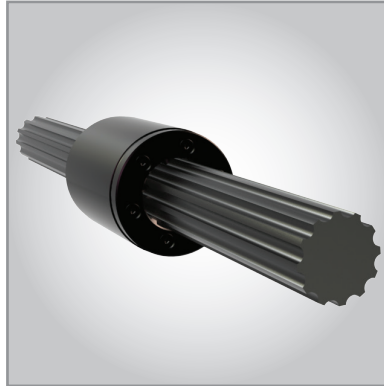

Precision Ball Screws



Ball Splines

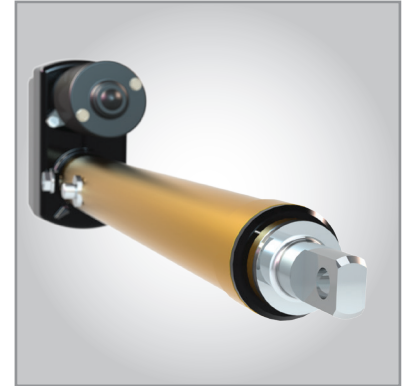

CC™ Cylinders



Worm Gear Screw Jacks

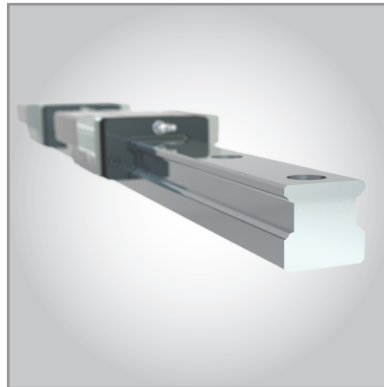

Profile Rails

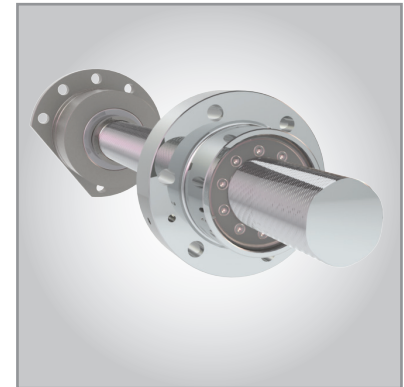

Planetary Roller Screws

HISTORY

In 1969, Joseph H. Nook Jr. founded Nook Industries, Inc., intent on becoming a global supplier of Linear Motion products. Ball screws, both rolled and ground, were the cornerstone products in the early 1970's, putting Nook Industries, Inc. on the map as a successful business and a trusted company.

Through the years, Nook Industries, Inc. has served as a leading manufacturer of engineered products. From

the first ball screws to the latest technologies, Nook Industries, Inc. strived to provide customers with high quality products and engineered solutions.

In 2021, Nook Industries, Inc. was acquired by Altra Industrial Motion Corp. and integrated into Thomson Industries, Inc. within the Automation & Specialty segment.

MARKET SEGMENTS SERVED



Aerospace



Tire Manufacture



Pulp & Paper



Packaging



Entertainment



Steel



Automotive



Semiconductor



Chemical



Electronics



Military and Defense



Medical & Diagnostic



Transportation



Factory Automation

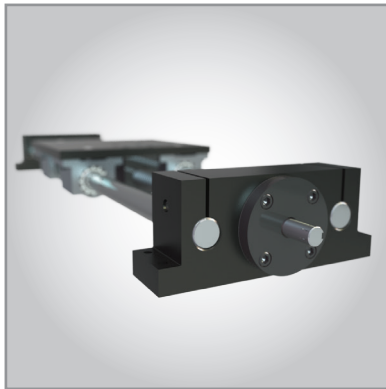

Linear Slides

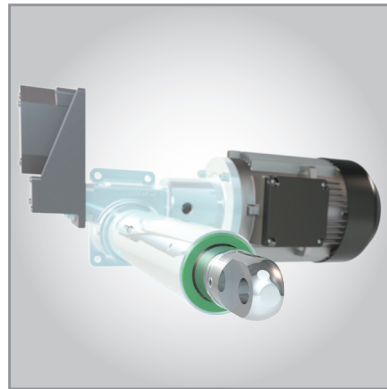

Electric Cylinders



EZZE Mounts™

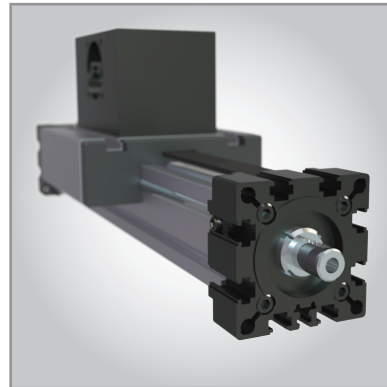

Modular Linear Actuators

TABLE OF CONTENTS

TECHNICAL INTRODUCTION.....	2-3
Selecting an Actuator	2
Screw Technology	3
ELECTRIC CYLINDERS.....	4-85
Introduction	4-15
ILA Electric Cylinders.....	16-29
DD Electric Cylinders	30-49
RAD Electric Cylinders	50-65
Accessories	66-85
PA ACTUATOR™	86-103
Features	88-95
Accessories	96-98
Speed.....	99-103
CC™ CYLINDERS	104-123
Introduction.....	104-109
Ball Screw Cylinder	110-111
Acme Screw Cylinder	112-113
Accessories	114-123
COMMERCIAL SERIES	124-132
VMD3 Linear Actuator	126-129
ND8 Linear Actuator	130-135
NIA5 Linear Actuator.....	136-141

MISSION

Companies around the world depend on the quality products provided by Nook/Thomson to ensure their success. Nook/Thomson provides a complete line of linear motion products, serving a wide range of market segments.

Pairing traditional and proven design with the latest technology, Nook/Thomson manufactures products that customers value. The expansion of product lines and the development of application specific components and engineered systems have propelled Nook/Thomson to the forefront of the industry.

Nook/Thomson is committed to customer satisfaction and providing high-quality, high-value products that are delivered on time at a competitive price.

PARTNERS



SELECTING AN ACTUATOR

ELECTRIC CYLINDERS

- Rugged
- Industrial
- Heavy Duty
- Harsh Environments

PA ACTUATOR™

- Programmable
- Square Extrusion Tube Structure
- Ease of Mounting
- Servo or Stepper option

CC™ CYLINDER & COMMERCIAL SERIES

- High Value
- Small Package
- Low Cost
- Feedback Options
- Flexible Mounting Options

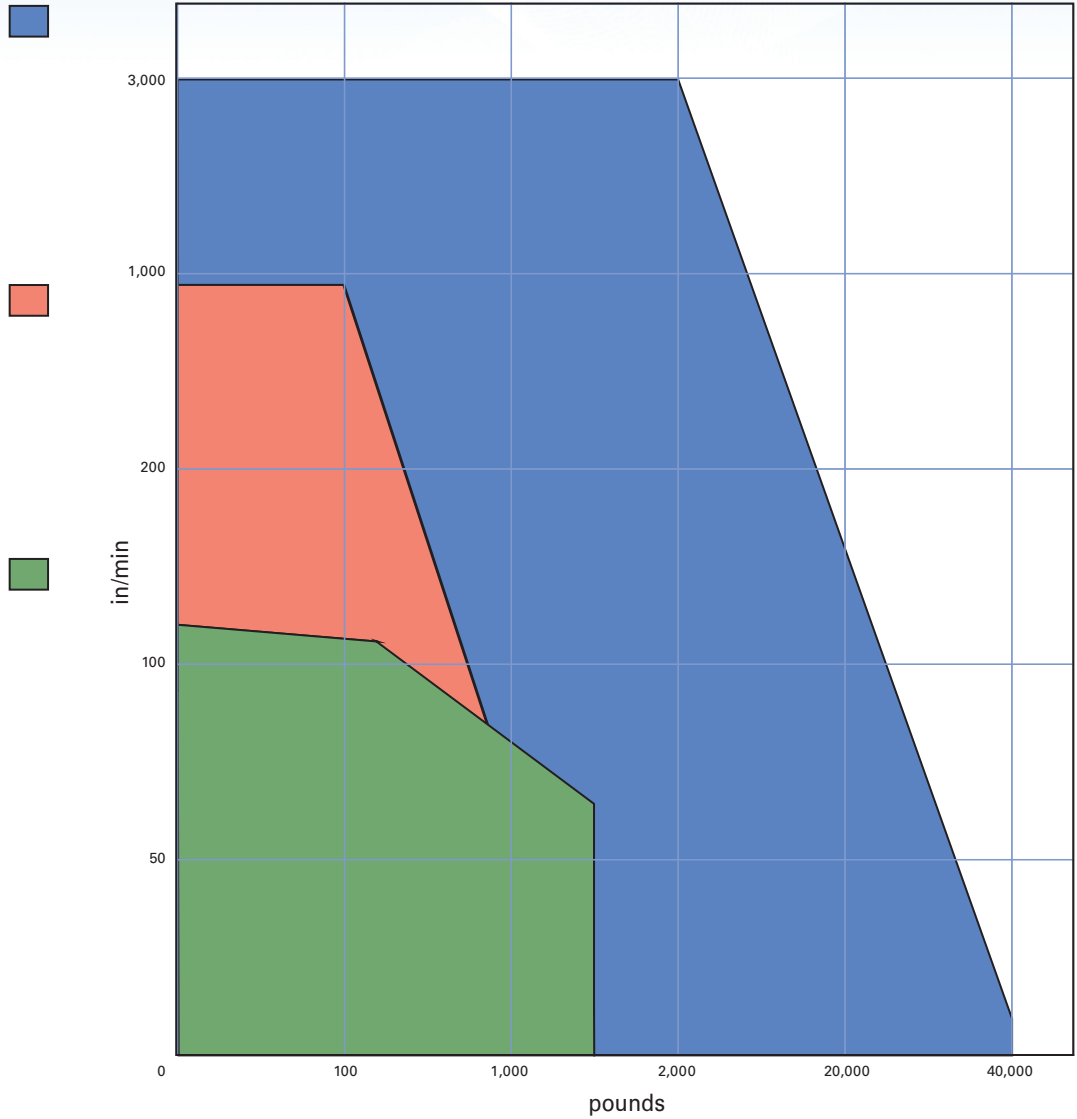

Nook/Thomson Linear Actuators are used in many light rail applications.

SCREW TECHNOLOGY

Nook/Thomson Linear Actuators use the finest acme and ball screws manufactured in the world.

ACME SCREWS

Nook/Thomson manufactures PowerAc™ precision acme screws by thread rolling for Electric Cylinders, PA Actuator™, and Commercial Series Actuators - a process that produces high-precision screws. Nook/Thomson Acme Screw products feature centralizing thread forms for smooth, no-wedging performance.

PowerAc™ Acme screws are made from 4140 Alloy steel with a black oxide finish with a 2C (Centralizing) thread form. Nook/Thomson acme nut material has been selected for low friction, minimum wear, long life, and clean operations.

BALL SCREWS

Nook/Thomson PowerTrac™ ball screws offer an efficient means of converting rotary motion to linear motion for Electric Cylinders, PA Actuator™, and Commercial Series Actuators. A ball screw is an improvement over an acme screw just as an antifriction ball bearing is an improvement over a plain bushing.

Ball screw assemblies have a number of bearing balls that transfer the load between the nut and screw. The thread form in which the bearing balls ride is an ogival shape formed from two arcs of the same radius with offset centers. This form is also referred to as a gothic arch.

Nook/Thomson ball screws are made of high strength materials. The screw shaft is made of medium carbon induction hardenable alloy steel. Ball nuts are manufactured from high grade bearing steel. Both the ball screw and nuts are heat-treated to a surface hardness not less than 56 HRC with a case depth suitably chosen to carry the load.

LEAD ACCURACY

SCREW	LEAD ACCURACY
Acme	± .0003 in/in up to 1½" dia.
Ball	± .004 in/ft

BACKLASH

Backlash (lash) is the relative axial movement between a screw and nut without rotation of the screw or nut. The axial movement between a new nut and screw will range from .003" to .015" depending on size. Lash in ball screws will remain constant during normal use.

BALL SCREW SELECTIVE FIT

When less than standard lash is desired, ball nuts can be custom-fit to a specific screw with selected bearing balls to minimize lash to .003" to .005" depending on ball size. Select fitting may result in lower life.

BALL SCREW PRELOAD NUTS

Nook/Thomson Linear Actuators can be modified to fit a preloaded nut, which is created by shifted internal threads that are ground. The resulting concentricity ensures uniform preload. Factory fitting on the ball screws provides a backlash-free system with uniform torque, high stiffness and long life.

LIFE

Ball screws use rolling elements to transfer a load similar to an anti-friction (ball) bearing. These elements do not wear during normal use, but rather fatigue. Therefore, ball screw life is predictable and is determined by calculating the fatigue failure of the components. Proper lubrication, regular maintenance, and operation within specified limits will allow Nook ball screws to operate to the predicted life.

	ACME SCREW	BALL SCREW
Max Speed	Moderate	High
Acceleration	Low	High
Life	Good	Better
Efficiency	Low to Moderate	High
Self Locking	Yes	No
Positioning Accuracy	Moderate	High
Stiffness	Very High	Moderate
Static Load	Moderate*	High
Dynamic Load	Moderate*	Low
Resistance to Failure From Shock Loading	High	Low
Resistance to Failure From Vibration	High	Low
Resistance to Failure From Dithering	High	Low
Ease of Installation	Easy	Easy
Manufacturing Time	Low	Moderate

* May double Dynamic Load with a double nut

PRECISION LINEAR ACTUATORS



Nook/Thomson Electric Cylinders are widely used in the satellite dish industry.



ELECTRIC CYLINDERS

TECHNICAL INTRODUCTION.....4-13

- Electric Cylinder Models6-7
- Definitions and Terms8-9
- Design Considerations..... 10-13
- Application Examples..... 14-15

ILA ELECTRIC CYLINDERS16-29

- ILA Series Technical Information 16-19
- Technical Data.....20-29

DD ELECTRIC CYLINDERS.....30-49

- DD Series Technical Information30-35
- Technical Data.....36-49

RAD ELECTRIC CYLINDERS50-65

- RAD Series Technical Information50-55
- Technical Data.....56-65

ACCESSORIES66-85

ELECTRIC CYLINDERS

Electric Cylinders are ruggedly designed and produced in standard models with thrust capacities from 500 lbs. to 40,000 lbs. Electric Cylinders are intended for use in industrial environments and feature precision-ground hard chrome-plated actuator tubes with industrial enamel paint on exterior surfaces. Epoxy paint is available on request. Electric Cylinders can be supplied for outdoor applications.

These cylinders may be used individually or in multiple arrangements. Each Electric Cylinder is built to specification.

ILA ELECTRIC CYLINDER

ILA In-Line Electric Cylinders are designed to have a motor or gear reducer directly coupled to the lift shaft. This provides for faster, more precise operation and/or higher duty cycles.

ILA Electric Cylinders feature standard trunnion pin mounting. They are easily adapted for use with servo motors and planetary gear reducers. Configurations are available with keyed actuator tubes.

In-line Electric Cylinders are Ball Screw actuated. Acme Screw models are also available; contact Nook Engineering.

DD WORM GEAR ELECTRIC CYLINDERS

DD worm gear driven Electric Cylinders incorporate an alloy steel worm which drives a high strength bronze worm gear (drive sleeve). The worm shaft is supported on anti-friction tapered roller bearings with external seals provided to prevent loss of lubrication (sealed radial ball bearings on the Series 5 and Series 10 units). The drive sleeve is supported on anti-friction tapered roller or ball thrust bearings. The electric cylinder housing is made of ductile iron and proportioned to support the rated capacity of the unit.



DD ELECTRIC CYLINDER

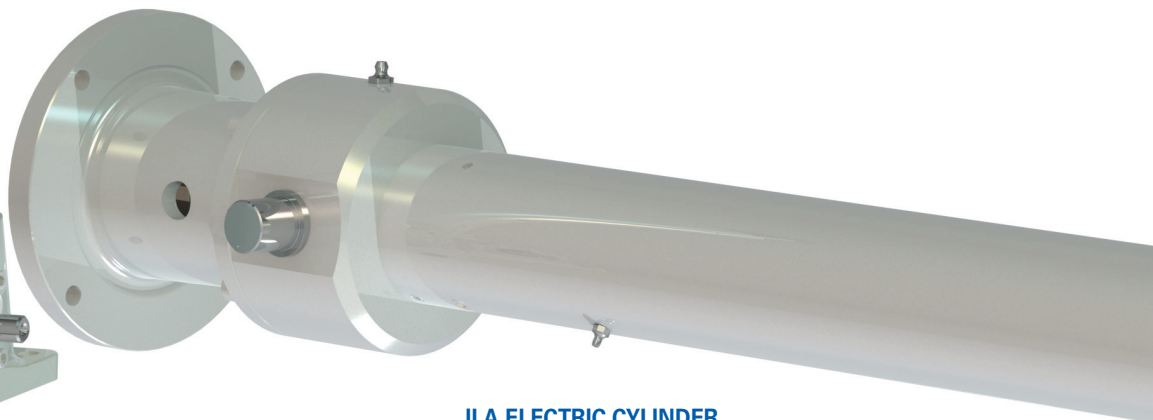

ILA ELECTRIC CYLINDER

In operation, the drive sleeve rotates the lift shaft causing the actuator tube to extend and retract from the housing tube. Actuator tube must be secured to prevent rotation. Special keyed actuator tubes are available.

For use in multiple cylinder arrangements, DD Electric Cylinders can be supplied without motor mounts.

DD Electric Cylinders are available in Acme Screw or Ball Screw versions and have a variety of worm gear ratios resulting in a wide range of speeds and thrust capacities.

RAD WORM GEAR ELECTRIC CYLINDERS

RAD worm gear driven Electric Cylinders incorporate the features of the DD with a second stage gear reduction. This secondary worm gear reduction of the RAD Electric Cylinders provides higher thrust at lower speeds. The reducer and motor can be mounted in eight possible positions for maximum flexibility.

RAD Electric Cylinders are available in Acme Screw or Ball Screw versions and have a variety of worm gear ratios resulting in a wide range of speeds and thrust capacities.

RAD ELECTRIC CYLINDER



DEFINITIONS & TERMS

BACKLASH

Backlash (lash) is the relative axial movement between a screw and nut without rotation of the screw or nut. Backlash in cylinders occurs wherever reversible load conditions exist. Backlash is less than .015" for all but the largest cylinder models. Ball Screw Cylinders can be factory adjusted to reduce backlash at the lift shaft by selecting bearing ball size in the ball nut. This selective fit technique can be used to achieve a minimal lash between the ball nut and ball screw of .003" to .005". Precision ball screws with preloaded nuts can be supplied when less than .003" backlash is required.

REACTION TORQUE

When an electric cylinder is used to move a load, the actuator tube must be secured to prevent rotation. The reaction torque required to prevent rotation is a function of the screw lead and the load applied on the cylinder. See product specification sheets for rod reaction torque. Prior to installation, the actuator tube can rotate freely in or out of the cylinder without movement of the input worm. This ability to rotate aids installation but prevents the optional rotary limit switch from being factory preset for end of travel positions.

Rod-Type Limit Switches prevent tube from freely rotating but are not intended to absorb the rod reaction torque.

TRAVEL LENGTH

Electric Cylinders are not pre-assembled or stocked with standard length screws. Each cylinder is made to order based on travel length.

Cylinders can be built with non-standard lead screws to change the cylinder operating speed or with ground or preloaded screws if required by the application. Contact Nook Industries for availability of special units.

LEAD ACCURACY

Lead accuracy is the difference between the actual distance traveled versus the theoretical distance traveled based on lead. For example: Consider a lift shaft with a .5" lead and +/- .004"/foot lead accuracy. If the shaft is rotated 24 times, the distance the nut moves is 11.996 to 12.004 inches.

The rolled thread screws, as employed in products, are held within +/- .004" per foot lead error.

INPUT TORQUE

The input torque is the rotary force required at the input of the cylinder to generate an output force at the actuator tube. The torque necessary to raise one pound is shown in charts on pages 18, 32-33, and 52-53. This number, multiplied by the load, is the required input torque.

Due to static friction, starting or "breakaway" torque can be as much as two to three times running torque. If the load is moved horizontally, the force required to move the load will be lessened in proportion to the coefficient of friction of the surface along which the load is moved. In addition, the force needed to start, stop and hold

the load (inertia loading) is provided by the cylinder. Cylinder sizing should consider all these forces.

If an application calls for several cylinders to be driven together in series, input torque values should be limited to three times the rated value of the first cylinder. For multiple high lead (HL, SL) ball screw cylinders contact Nook/Thomson for allowable input torque values. Multiple cylinders driven in a series may require operation at reduced load.

INPUT SPEED

DD and RAD Electric Cylinder models are rated at 1,725 rpm input. If provided with a servo motor, cylinders may be operated up to 3,000 rpm provided horsepower and temperature ratings are not exceeded. Contact Nook/Thomson engineers if higher speeds are required.

When using variable speed motors, use the "Turns of Worm Per Inch Of Travel" information from the Electric Cylinder Design Data table to determine actual travel speed. Input speed (rpm) divided by input turns per inch of travel produces the travel speed in inches per minute.

NOTE: Maximum horsepower values should not be exceeded.

DUTY CYCLE

Duty cycle is the ratio of run time to total cycle time. Some of the electrical energy input to an electric cylinder is converted into heat. The duty cycle is limited by the ability of the electric cylinder to dissipate this heat. An increase in temperature can affect the properties of some components resulting in accelerated wear, damage and possible unexpected failure.

Ratings for DD and RAD Electric Cylinders are based on intermittent operation. The approximate allowable duty cycles for DD and RAD worm gear cylinders are:

Ball Screw versions = 35%
Acme Screw versions = 25%

Duty cycle is based on standard ambient temperature, with 1 minute on 2 minute off cycles. For operation at higher duty cycles or repeated use over any segment of the total travel, housing temperature must be monitored and remain less than 200°F. Continuous or heavy duty operation is possible by de-rating the cylinder capacity, external cooling of the unit, or through the use of a recirculating lubrication system.

ILA and ILAK cylinders are direct drives with no internal gears. Duty cycle for these cylinders is a function of the motor or add-on gear box.

SELF-LOCKING AND BRAKES

Self-locking occurs when system efficiencies are low enough that the force on the actuator lifting tube cannot cause the drive system to reverse direction. Electric Cylinders that utilize acme screws and have ratios of 20:1 or greater are self-locking and, in the absence of vibration, will hold loads without backdriving. All other models require a motor brake to prevent backdriving.

Holding torque is the amount of input torque required to restrain the load once stopped. The standard brake torque shown in the product specification sheets for DD and RAD Cylinders will stop low inertia loads within the stopping distances shown. Larger brakes may be required to stop high inertial loads, or to stop travel in shorter distances. Contact Nook Industries for recommendations.

TEMPERATURE

All Electric Cylinders are suitable for operation within the specified limits, provided that the housing temperature is not lower than -20°F or higher than +200°F. Factory supplied grease in standard units will operate in this range. For higher or lower operating temperature ranges contact Nook Industries, for recommendations.

END-OF-TRAVEL STOPS

Travel stops are not standard. A limit switch and a brake should be used to stop the motor. Mechanical stops can cause damage to the cylinders because most electric motors will deliver stall torques much higher than their rated torques and motor inertia can cause severe shock loads. For hand operation, mechanical stops can be provided.

MAXIMUM LOAD

The maximum thrust load, including shock, that can be applied to the actuator without damaging the assembly.

DYNAMIC CAPACITY

The maximum allowable thrust load based on horsepower, thrust bearing, and screw limitation.

TENSION LOAD

A load that tends to "stretch" the screw.

COMPRESSION LOAD

A load that tends to "squeeze" the screw.



Nook/Thomson Linear Actuators used in a roadside lighting column.

DESIGN CONSIDERATIONS

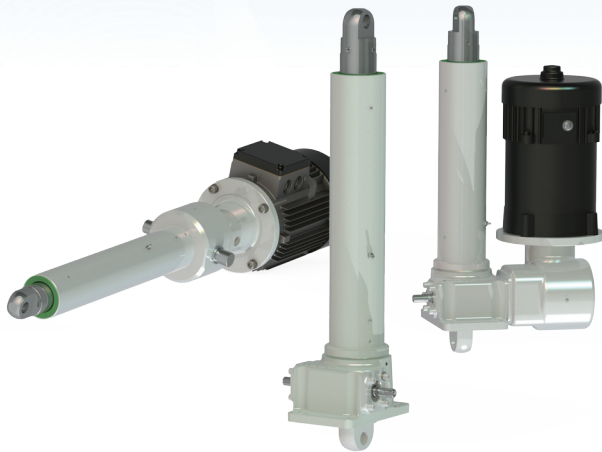

LOAD CAPACITY

All anticipated loads should be within the rated capacity of the cylinder. Loads on the cylinder in most applications include: static loads, dynamic or moving loads, cutting or other reaction forces and acceleration/deceleration loads.

For shock loads, the peak load must not exceed the rated capacity of the cylinder, and an appropriate design factor should be applied commensurate with the severity of the shock.

For accidental overloads not anticipated in the design of the system, cylinders can sustain the following overload conditions without damage: 10% for dynamic loads, 30% for static loads. For multiple cylinder systems, load distribution should be considered. System stiffness, center of gravity, drive shaft windup and lead variation in the lift shafts may result in unequal load distribution.

HORSEPOWER RATINGS

Standard DD and RAD Electric Cylinder Models are supplied with electric brake-motors sized for the load and speed rating of the cylinder.

The horse power rating of the DD and RAD Cylinders are based on max duty cycle running at standard ambient temperature, with 1 minute on 2 minute off cycles.

If an Electric Cylinder is applied at less than rated capacity, higher duty cycles may be possible. The best way to determine allowable duty cycle is to measure the cylinder gear housing temperature. The temperature of the housing near the worm must not exceed 200°F.

For Electric Cylinders supplied without brakemotors, use the information in the “Electric Cylinder Design Data” chart on pages 18, 32-33, and 52-53 for motor sizing. The horsepower is calculated by using the following formula:

$$\text{Horsepower per cylinder} = \frac{\text{Torque to raise one pound} \times \text{Number of pounds to be raised} \times \text{Input rpm}}{63,025}$$

The “Torque to raise one pound” value is particular to each cylinder and can be obtained from the “Electric Cylinder Design Data” charts on pages 18, 32-33, and 52-53.

Maximum horsepower ratings are based on intermittent operation. To determine whether performance is within horsepower and duty cycle limits, measure the cylinder temperature. The temperature of the housing near the worm (or at the thrust bearing mounting block for ILA cylinders) must not exceed 200°F.

CAUTION: Do not exceed the maximum allowable input horsepower for a cylinder.

COLUMN STRENGTH

Electric Cylinder capacity may be limited by its column strength. Column strength is the ability of the cylinder to hold compressive loads without buckling. With longer screw lengths, column strength can be substantially lower than nominal cylinder capacity. When the lift screw is in tension only, travel is limited by available screw and/or tube material or by screw critical speed. If there is any possibility for the cylinder to go into compression, the application should be checked for sufficient column strength. The charts on each cylinder specification page are used to determine the cylinder size in applications where the lift screw is loaded in compression.

The charts assume proper cylinder alignment with no bending loads present. Effects from side loading are not included in this chart. Also, cylinders operating horizontally with long lift screws can have significant bending from the weight of the screw and tubes. Consult Nook Industries if side loads are anticipated.

CYLINDER SIZING DATA

Cylinders are limited by two constraints: load capacity and horsepower. The load capacity of the cylinder is limited by the physical constraints of its components (drive sleeve, lift shaft, bearings, etc.). The horsepower limit of the cylinder is a result of the ability to dissipate the heat generated from the inefficiencies of its components.

In order to test for these constraints, application information must be collected. The data required to size a cylinder includes:

1) Total Load – The total load includes static loads, dynamic loads and inertia loads from acceleration and deceleration. Also consider reaction forces received from the load such as drilling or cutting forces when using a cylinder to move a machine tool.

2) Number of Cylinders – The number of cylinders used depends on physical size and design of the equipment. Stiffness of the equipment structure and guide system will determine the appropriate number of cylinders required. Fewer cylinders are easier to drive, align and synchronize. For multiple-cylinder arrangements, do not assume equal loading. Calculations should be based upon “worst case” unequal loading.

3) Travel Rate – Establishing a travel rate allows for a quick cylinder selection and will be used to evaluate critical speed and horsepower

limits. The desired rate should include time for acceleration/ deceleration.

4) Travel – Travel is the total distance the cylinder extends. This is the number that is used to calculate maximum compressive load. For cylinders with nonstandard retracted lengths, include the additional length in the compressive load evaluation.

5) Duty Cycle – The duty cycle is the ratio of run time to the total cycle time.

6) Type of Guidance – Every linear motion system needs something to move the load and something to guide the load. The degree of guidance (stiffness, accuracy, etc.) is based on application requirements.

CYLINDER SELECTION

Once the cylinder sizing information is collected, a preliminary cylinder selection can be made and verified.

1) Select a Standard Cylinder – Use the DD, RAD, and ILA Design Data and Quick Reference Charts on pages 18, 32-33, and 52-53 to find a unit which matches the desired force and speed. Choose between a ball screw or acme screw model based on duty cycle (model suffixes which begin with “A” are acme models).

2) Travel Length – When a unit is chosen, go to the product specification page for that model. Check that the desired travel length does not exceed column strength and maximum travel limits. A larger capacity cylinder may be required in order to stay within these limits.

NOTE: Travel length must include any over-travel to accommodate stopping distance.

3) Reference Number – Use the information on page 19, 35, or 55 to specify a complete Electric Cylinder Reference Number.

If the cylinder is to be used with a motor other than those listed in the catalog, if multiple cylinders are used or if the cylinder is manually operated, go to the Electric Cylinder Design Data on pages 18, 32-33, and 52-53.

1) Select a Cylinder – Choose a model whose basic capacity matches or exceeds the expected load. Make certain the dynamic and static loads do not exceed the cylinder capacity. In multiple cylinder applications, check the distribution of the load for potential uneven loading on the cylinders.

2) Speed – Use the “turns for one inch of travel” from the chart to determine the input speed required. If travel rate and motor speed are known, divide the motor speed (rpm) by the travel rate (inches per minute) to determine the “turns for one inch of travel.”

3) Motor Horsepower – Calculate the horsepower required from the load, speed and “torque to raise one pound value” from the chart. Use the horsepower calculation on page 10.

If using the cylinders in multiple cylinder systems, check the total horsepower. Remember that additional gearboxes and couplings used to distribute power to the cylinders are not 100% efficient.

If the horsepower required exceeds the maximum value for the cylinder selected, several solutions are possible.

- Use a larger cylinder model to increase the maximum allowable horsepower
- Use a Ball Screw Cylinder to reduce the power required to do the same work
- Operate at a lower input speed
- Use a RAD cylinder to bring the power requirement within acceptable limits

Upon selecting a motor and brake, verify that the brake has sufficient torque to both hold the load and stop the load.

CAUTION: Cylinders with high lead ball screws (HL and SL) may require larger brakes to stop the load. An appropriately sized brake will insure against excessive “drift”

4) Column Strength – If it is possible for the cylinder to be loaded in compression, check for column strength. Consider cases where a unit normally loaded in tension can be compressively loaded if it runs into an obstruction. Also check horizontal applications for compressive loading due to acceleration or deceleration.

5) Cycle Time – If using a worm gear style Electric Cylinder, make sure cycle time does not exceed the allowable duty cycles.

6) Life – For Ball Screw Cylinders, check life expectancy against the life charts.

7) Reference Number – Use the information on page 19, 35, or 55 to specify a complete Electric Cylinder Reference Number.

INSTALLATION

The alignment of the cylinders directly affects their service life. Cylinders must be properly aligned in all planes so the actuator tube can move in and out without evidence of binding.

Since the majority of cylinder applications use the cylinders with clevis or trunnion mounts, simply align the clevises and install the cylinder.

Set limit switches before operating. Allow for drift when setting the position. The actuator tube can move (rotate) until the unit is installed. Turn the actuator tube in or out to get the cylinder to a known position before installation to prevent over-travel.

DESIGN CONSIDERATIONS (CONTINUED)

MAINTENANCE

Electric Cylinders require minimum maintenance. In addition to maintaining lubrication levels in the gearbox and tubes, the following items should be checked:

- The actuator tube should be kept free of dirt. If possible, the actuator should be returned to the retracted position when not in use.
- For acme cylinders, lash between the lift shaft and travel nut greater than $\frac{1}{4}$ the screw pitch indicates the need for replacement of the cylinder lift shaft components.
- For machine screw or ball screw worm gear Electric Cylinders, check for excessive backlash between the worm and worm gear. Lash in excess of 30° for ratios 5:1 to 8:1 and 60° for ratios 20:1 and 24:1 indicates the need to replace the worm and worm gear.

LUBRICATION

Electric Cylinders require lubrication to operate efficiently and with maximum life. Standard lubrication is NLGI #2 grease. If operating conditions exceed -20°F to 200°F , contact Nook/Thomson, for alternative lubricants.

The cylinder gear boxes are shipped pre-greased unless otherwise specified. Before operating any unit, check the lubricant level. All cylinder housings are furnished with a grease fitting. Most have a pipe plug opposite the grease fitting. When adding grease to the housing, remove the pipe plug and fill the unit until grease exits the pipe plug opening. Overfilling the cylinder may result in grease leakage from the seals.

In normal operation, cylinder lubricant levels should be checked once per month. Application conditions may dictate a more or less frequent lubrication cycle. In extreme conditions, automatic lubrication may be desired.

Lubricants containing additives such as molydisulfide or graphite should not be used.

The lift shafts (ball and acme screws) inside the Electric Cylinder actuator tube receive lubrication through the fittings on the outside of the housing tube. Lubrication added to the housing tube can pass to the screw regardless of actuator tube position. The best way to lubricate this section of the cylinder is to add some lubricant when the cylinder is fully retracted and additional lubricant when the cylinder is extended beyond where the guide is past the lube port (see cylinder cutaway views on pages 17, 31, and 51).



H ARRANGEMENT



T ARRANGEMENT

REQUIRED APPLICATION DATA

Load

- Total maximum thrust load on cylinders
- Total maximum thrust load on any one cylinder
- Number of cylinders

Travel

- Inches
- Orientation (vertical, horizontal, arc, diagonal, etc.)

Travel Rate

- Optimal speed
- Minimal acceptable speed
- Maximum acceptable speed

Duty Cycle

- Distance per cycle
- Number of cycles per time period
- Maximum distance traveled in any year
- Life desired

Configuration

- Tension, compression, or both
- Driven by motor or other
- Translating, Rotating, or Double Clevis

Arrangement

- Arrangement Type, (H, T, U, Inline)
- Arrangement Dimensions (X, Y1, Y2, etc.)

For dimension information, please refer to the guides online at www.nookindustries.com.



Nook Electric Cylinders are used in many maritime applications.



U ARRANGEMENT



IN-LINE ARRANGEMENT

APPLICATION EXAMPLES

APPLICATION #1 – DISTRIBUTION CONVEYOR

An agricultural conveyor system distributes filler material across a 48 inch wide packaging line. One end of the conveyor is hinged to a loading station, the other end must move across the conveyor.

SPECIFICATIONS:

- The maximum load from the conveyor with material is 1,100 lb
- A servo drive will be used to control the actuator
- The conveyor will move 480 times per hour, 16 hours per day, 350 days per year
- Life expectancy is 5 years
- Travel length is 24 inches maximum
- Minimum Travel Rate is 24 inches in 3 seconds

ANALYSIS:

An In-Line cylinder will be used because of the frequent cycle requirement. With a travel rate of 480 inches per min ((24 inches / 3 seconds) × 60 seconds) and a life expectancy of 15 million inches, an ILA-10-HL is selected. The application would require a servomotor that can produce 96.8 inch-lbs of torque (0.088 inch-lbs × 1,100 lbs) at 960 rpm (480 inches per min / .500 Lead).

SELECTION:

ILA-10-HL / SPC / TC/ 24 / M

M - Custom motor mount to fit customer-specified servo motor.



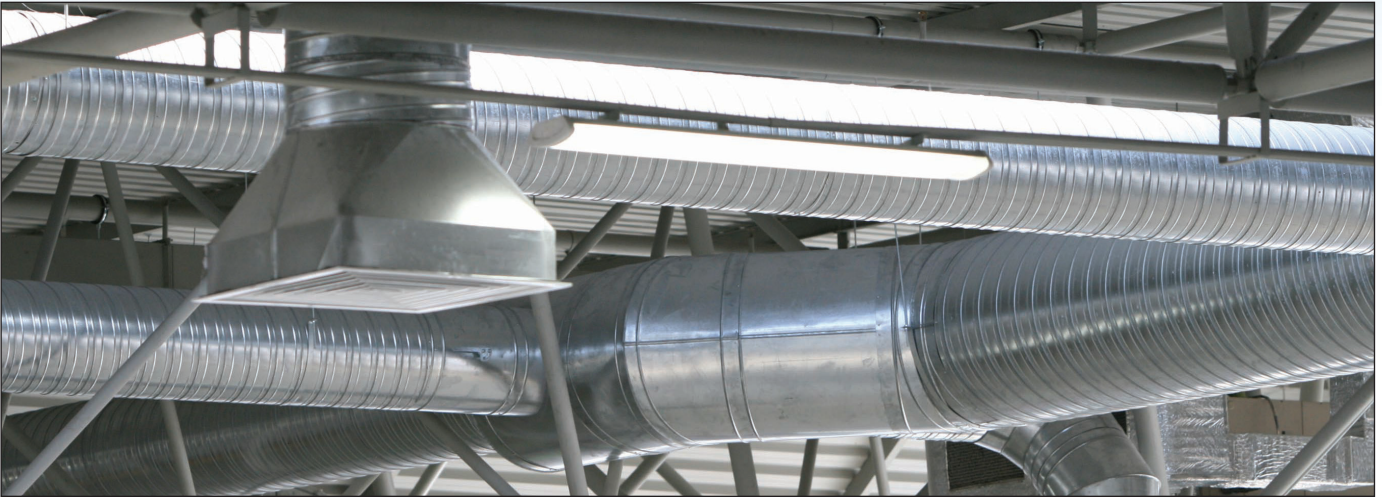

APPLICATION #2 – HVAC DUCT VALVE

An HVAC 6' x 6' duct valve is located 30 feet above a manufacturing process facility floor. The baffle needs to be adjusted periodically to maintain proper airflow through the building. The loads, duty cycle and other operation details have been identified. The concern is with the amount of dust and particulate that will accumulate on the actuator due to the fact that it is located directly above foam manufacturing equipment.

SPECIFICATIONS:

- Maximum force to open and close the valve under maximum airflow is 2,000 lb
- Cylinder will be in compression
- Maximum speed is 32 inches per minute
- Actuation cycle: 2 times per day; 365 days per year
- Desired design life is twenty years
- Mechanism must be mounted overhead
- Limit switches required
- Maximum travel is 18 inches

ANALYSIS

There is a specific life requirement so a ball screw actuator is required. As shown on the Series DD-25 product reference pages 40-41, using the DD-2512-HD with a ½ hp brake motor will provide a travel rate of 36"/min and give 4.1 million inches of life at 2,000lbs.

Additionally, the charts show that this application is within the column load strength of the DD-2512-HD. The door swings through an arc so a double clevis style will be required. Due to the environment concerns, an enclosed Rotary Limit Switch should be used instead of a Rod-Type Limit Switch.

SELECTION:

DD-2512-HD / 05BT -1 / 2CA - 4E / CC / 18 / S



ILA ELECTRIC CYLINDERS

ILA Electric Cylinders have many of the same benefits of DD and RAD Electric Cylinders, including a rugged design and capacities from 1,000 lb to 21,000 lb. ILA Electric Cylinders incorporate a direct drive without an internal reduction. The screw drive is directly coupled with an external speed reducer, stepper motor, servo motor, or NEMA mounted motors.

ILA Electric Cylinders can be supplied for outdoor applications. Each Electric Cylinder is built to specification. Custom motor or reducer mounts are available.

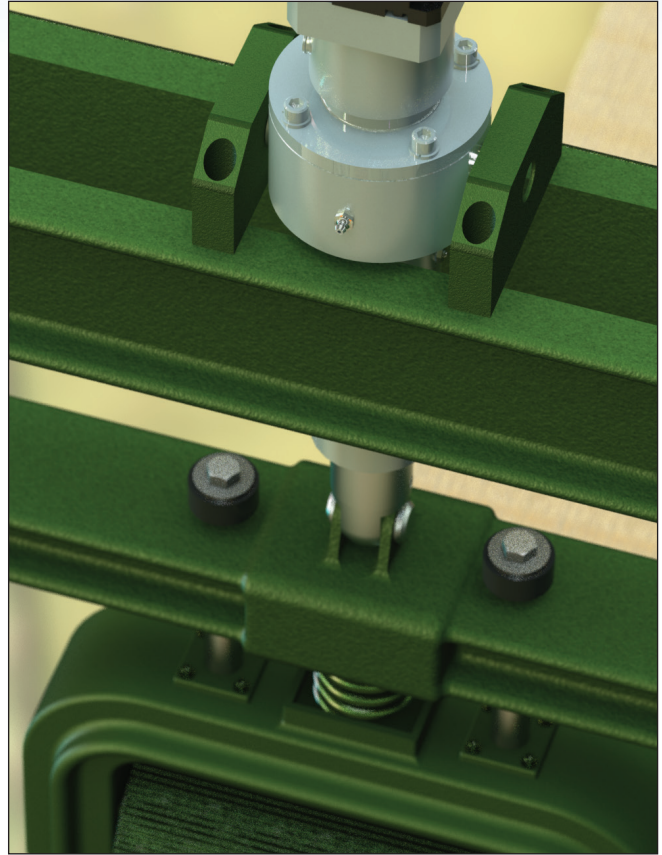

Nook/Thomson Electric Cylinders used in a commercial sawmill.



ILA ELECTRIC CYLINDERS20-21
Design Data 20
Reference Number System 21

ILA ELECTRIC CYLINDERS
TECHNICAL DATA22-31
Series ILA-5 & ILAK-5 22-23
Series ILA-10 & ILAK-10 24-25
Series ILA-25 & ILAK-25 26-27
Series ILA-100 & ILAK-100 28-29
Series ILA-200 & ILAK-200 30-31

ILA DESIGN DATA

	MODEL NUMBER	SCREW SIZE	INPUT TURNS PER INCH OF TRAVEL	TORQUE TO RAISE 1 LB (IN-LB)	MAX LOAD (LB)
5 SERIES	ILA - 5 HL	0631-0500 SRT RA	2	0.088	1,000
	ILA - 5 HD	0631-0200 SRT RA	5	0.035	1,000
	ILAK - 5 HL	0631-0500 SRT RA	2	0.088	1,000
	ILAK - 5 HD	0631-0200 SRT RA	5	0.035	1,000
10 SERIES	ILA - 10 HL	0750-0500 SRT RA	2	0.088	1,200
	ILA - 10 HD	0750-0200 SRT RA	5	0.035	2,200
	ILAK - 10 HL	0750-0500 SRT RA	2	0.088	1,200
	ILAK - 10 HD	0750-0200 SRT RA	5	0.035	2,200
25 SERIES	ILA - 25 HL	1000-1000 SRT RA	1	0.177	2,200
	ILA - 25 ML	1000-0500 SRT RA	2	0.088	3,500
	ILA - 25 HD	1000-0250 SRT RA	4	0.044	3,500
	ILAK - 25 HL	1000-1000 SRT RA	1	0.177	2,200
	ILAK - 25 ML	1000-0500 SRT RA	2	0.088	3,500
	ILAK - 25 HD	1000-0250 SRT RA	4	0.044	3,500
100 SERIES	ILA-100 SL	1500-1875 SRT RA	.53	0.332	2,500
	ILA-100 HL	1500-1000 SRT RA	1	0.177	4,600
	ILA-100 HD	1500-0473 SRT RA	2.11	0.084	9,000
	ILAK-100 SL	1000-1875 SRT RA	.53	0.332	2,500
	ILAK-100 HL	1500-1000 SRT RA	1	0.177	4,600
	ILAK-100 HD	1500-0473 SRT RA	2.11	0.084	9,000
200 SERIES	ILA-200 HL	2250-1000 SRT RA	1	0.177	11,000
	ILA-200 HD	2250-0500 SRT RA	2	0.088	21,000
	ILAK-200 HL	2250-1000 SRT RA	1	0.177	11,000
	ILAK-200 HD	2250-0500 SRT RA	2	0.088	21,000

Optional Configuration - Contact Nook Engineering

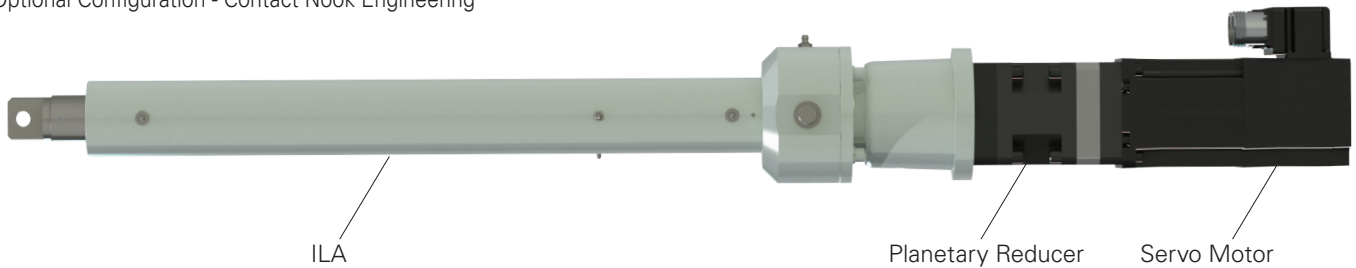

REFERENCE NUMBER SYSTEM

ILA-100-HD / X05 / TC / 24.5 / S

SERIES ILA MODEL

Refer to product pages for available models.

- ILA = Standard In-Line Actuator
- ILAK = Keyed In-Line Actuator

MOTOR MOUNT CODES

SPC_ = Special Modified Motor Mount

Motor Mounts Without Motor (Refer to product pages for available models.)

NEMA Frame Mounts

- X04 = (48C) ILA-5, ILAK-5, ILA-10, ILAK-10
- X05 = (56C) All models except ILA-200, ILAK-200
- X14 = (140TC) All models except ILA-5, ILAK-5, ILA-10, ILAK-10
- X18 = (180TC) ILA-100, ILAK-100, ILA 200, ILAK-200
- X21 = (210TC) ILA-100, ILAK-100, ILA 200, ILAK-200

IEC Frame Mounts

- 56B5 = ILA-5, ILAK-5
- 56B14 = ILA-5, ILAK-5
- 63B5 = ILA-10, ILAK-10
- 63B14 = ILA-10, ILAK-10
- 71B5 = ILA-10, ILAK-10, ILA-25, ILAK-25
- 71B14 = ILA-10, ILAK-10, ILA-25, ILAK-25
- 80B5 = ILA-25, ILAK-25, ILA-100, ILAK-100
- 80B14 = ILA-25, ILAK-25, ILA-100, ILAK-100
- 90B5 = ILA-100, ILAK-100
- 90B14 = ILA-100, ILAK-100
- 100B5 = ILA-100, ILAK-100, ILA0-200, ILAK-200
- 100B14 = ILA 100, ILAK-100, ILA0-200, ILAK-200

* Unless specified at the time of order, the electric cylinder will be supplied with a jaw-type coupling that may reduce the allowable torque input. For more information please contact Nook application engineers.

HOUSING CONFIGURATION

T = Standard Trunnion Pins

ROD CONFIGURATION

- T = Threaded End
- C = Clevis End
- D = Threaded rod end with female clevis installed
- P = Top Plate

TRAVEL

Travel in inches

MODIFIER LIST

- Always S, B or M
- S = Standard. no additional description required
- B = Bellows Boots (See pages xxx-xxx)

SERIES ILA-5 & ILAK-5

TRUNNION MOUNT PART NUMBER 9015-5

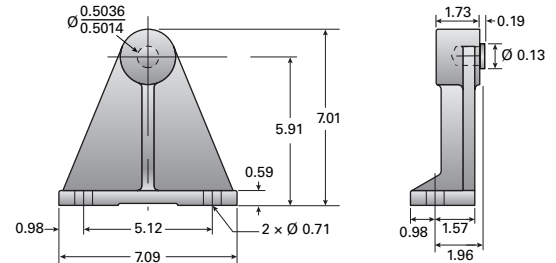

MODEL NUMBER	Maximum Load (lb)	Max Input Torque (in.-lb.)	Max Travel Rate (in./min)	Ball Screw Model Number	Torque per lb. (in.-lb.)	Basic Weight (lb)	Dimensions	
							A	B
ILA-5 HL	1.000	88	2,377	0631-0500 SRT	0.088	29	2.25	2.25
ILA-5 HD	1.000	35	951	0631-0200 SRT	0.035	29	2.25	2.25
ILAK-5 HL (keyed)	1.000	88	2,377	0631-0500 SRT	0.089	29	3.50	3.50
ILAK-5 HD (keyed)	1.000	35	951	0631-0200 SRT	0.036	29	3.50	3.50

Total Weight = (0.87 lb) × Travel + Basic Weight
 Rod Reaction Torque = Torque per lb. × Load

NOTE: Cylinder is self-lowering.
 Input shaft must be secured to prevent rotation.

NOTE: Nook/Thomson ILA Series cylinders can be supplied with motor mounts. The sizes listed in the chart are mounts designed to match up to common motor faces. Application torque requirements and coupling size, style and attachment method will affect the size of the motor mount. See reference number pages 68 and 69 for motor mount/cylinder model availability. A custom motor mount can be manufactured to your specifications, please contact Nook/Thomson.

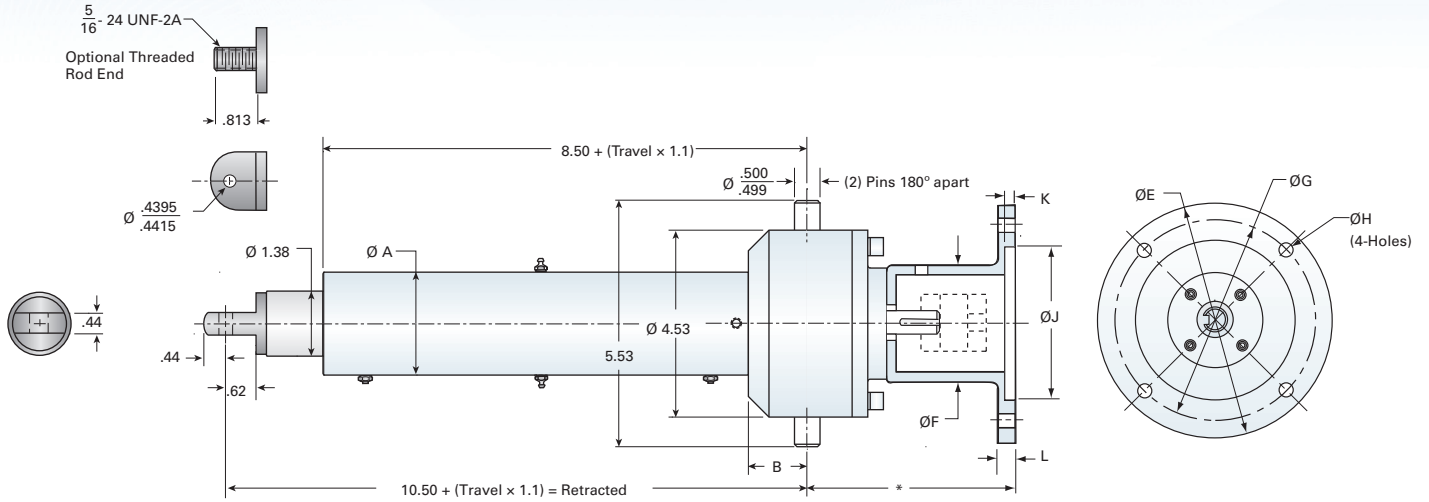

* Dimension based on motor mount. Contact factory with your specific requirements

Motor Frame	Frame Size	ØE	ØF	ØG	ØH	ØJ	K	L
NEMA	48	4.63"	3.12"	3.75"	.28"	3.00"	.16"	.50"
IEC	56B5	120mm	64mm	100mm	8.5mm	80mm	3.5mm	7mm
IEC	56B14	80mm	64mm	65mm	6mm	50mm	3.0mm	6mm

Servo or stepper motors are available.

COLUMN LOAD

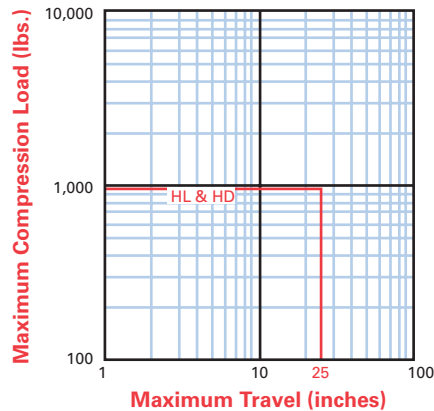

CRITICAL SPEED

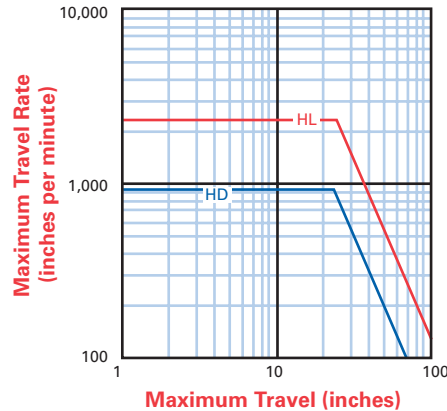

LIFE EXPECTANCY

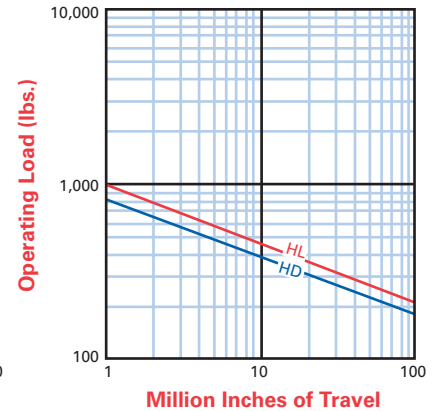

SERIES ILA-10 & ILAK-10

TRUNNION MOUNT PART NUMBER 9015-10

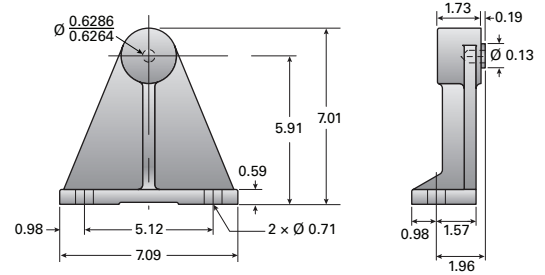

MODEL NUMBER	Maximum Load (lb)	Max Input Torque (in.-lb.)	Max Travel Rate (in/min)	Ball Screw Model Number	Torque per Lb. (in.-lb.)	Basic Weight (lb)	Dimensions	
							A	B
ILA-10 HL	1,200	105	2,000	0750-0500 SRT	0.088	32	2.50	1.44
ILA-10-HD	2,200	77	800	0750-0200 SRT	0.035	32	2.50	1.44
ILAK-10 HL (Keyed)	1,200	105	2,000	0750-0500 SRT	0.089	32	4.00	1.25
ILAK-10 HD (Keyed)	2,200	77	800	0750-0200 SRT	0.036	32	4.00	1.25

Total Weight = (0.98 lb) × Travel + Basic Weight
 Rod Reaction Torque = Torque per lb. × Load

NOTE: Cylinder is self-lowering.
 Input shaft must be secured to prevent rotation.

NOTE: Nook/Thomson ILA Series cylinders can be supplied with motor mounts. The sizes listed in the chart are mounts designed to match up to common motor faces. Application torque requirements and coupling size, style and attachment method will affect the size of the motor mount. See reference number pages 68 and 69 for motor mount/cylinder model availability. A custom motor mount can be manufactured to your specifications, please contact Nook/Thomson.

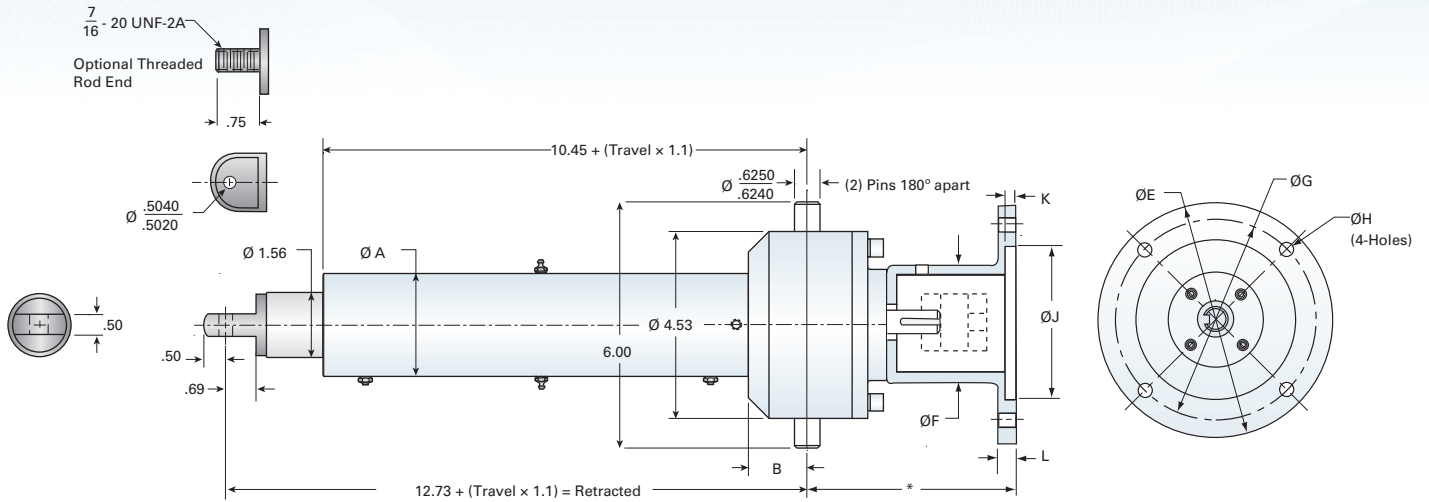

* Dimension based on motor mount. Contact factory with your specific requirements

Motor Frame	Frame Size	ØE	ØF	ØG	ØH	ØJ	K	L
NEMA	56C	6.75"	3.50"	5.88"	.41"	4.50"	.16"	.50"
IEC	63B5	140mm	70mm	115mm	9mm	95mm	4mm	8mm
IEC	63B14	90mm	70mm	75mm	6mm	60mm	3.5mm	8mm
IEC	71B5	160mm	85mm	130mm	9mm	110mm	4.5mm	10mm
IEC	71B14	105mm	85mm	85mm	7mm	70mm	4mm	10mm

Servo or stepper motors are available.

COLUMN LOAD

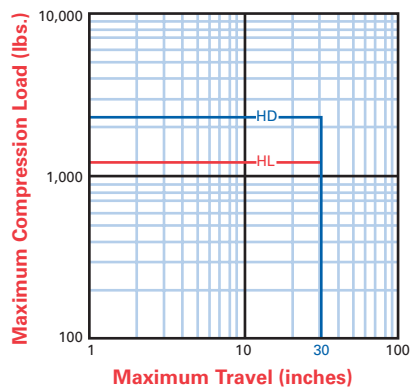

CRITICAL SPEED

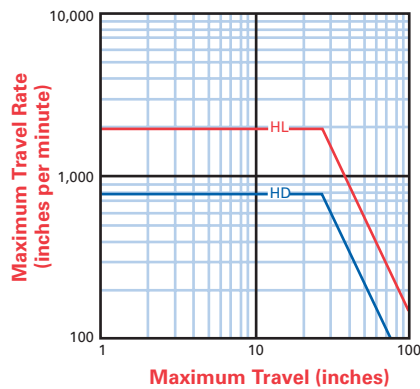

LIFE EXPECTANCY

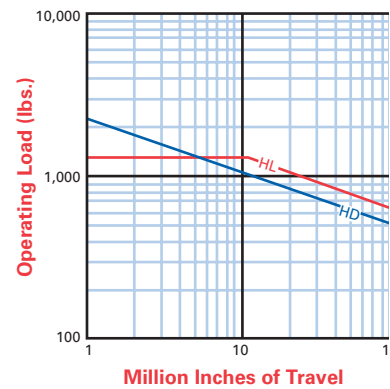

SERIES ILA-25 & ILAK-25

TRUNNION MOUNT PART NUMBER 9015-25

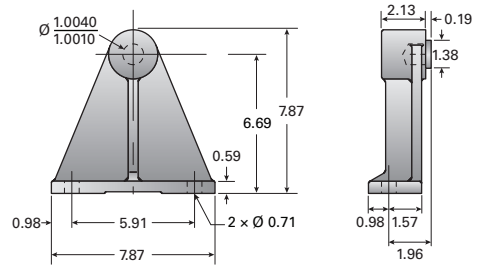

MODEL NUMBER	Maximum Load (lb)	Max Input Torque (in.-lb.)	Max Travel Rate (in/min)	Ball Screw Model Number	Torque per Lb. (in.-lb.)	Basic Weight (lb)	Dimensions	
							A	B
ILA-25 HL	2,200	390	3,000	1000-1000 SRT	0.177	47	3.00	1.50
ILA-25-ML	3,500	308	1,500	1000-0500 SRT	0.088	47	3.00	1.50
ILA-25-HD	3,500	154	750	1000-0250 SRT	0.044	47	3.00	1.50
ILAK-25 HL (Keyed)	2,200	390	3,000	1000-1000 SRT	0.179	47	4.00	1.25
ILAK-25-ML (Keyed)	3,500	308	1,500	1000-0500 SRT	0.093	47	4.00	1.25
ILAK-25-HD (Keyed)	3,500	154	750	1000-0250 SRT	0.044	47	4.00	1.25

Total Weight = (1.29 lb) × Travel + Basic Weight
Rod Reaction Torque = Torque per lb. × Load

NOTE: Cylinder is self-lowering.
Input shaft must be secured to prevent rotation.

NOTE: Nook/Thomson ILA Series cylinders can be supplied with motor mounts. The sizes listed in the chart are mounts designed to match up to common motor faces. Application torque requirements and coupling size, style and attachment method will affect the size of the motor mount. See reference number pages 68 and 69 for motor mount/cylinder model availability. A custom motor mount can be manufactured to your specifications, please contact Nook/Thomson.

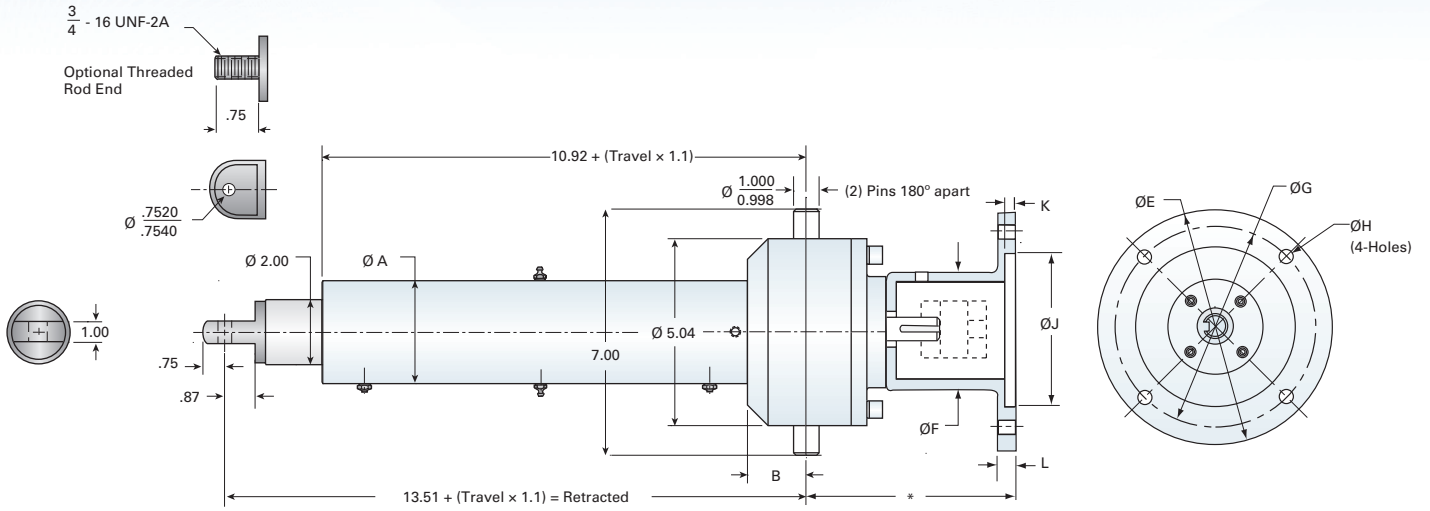

* Dimension based on motor mount. Contact factory with your specific requirements

Motor Frame	Frame Size	ØE	ØF	ØG	ØH	ØJ	K	L
NEMA	56C	6.75"	3.75"	5.88"	.41"	4.50"	.16"	.50"
NEMA	140TC	6.75"	3.75"	5.88"	.41"	4.50"	.16"	.50"
NEMA	180TC	9.25"	3.75"	7.25"	.56"	8.50"	.28"	.75"
IEC	71B5	160mm	85mm	130mm	9mm	110mm	4.5mm	10mm
IEC	71B14	105mm	85mm	85mm	7mm	70mm	4mm	10mm
IEC	80B5	200mm	85mm	165mm	11mm	130mm	4.5mm	12mm
IEC	80B14	120mm	85mm	100mm	7mm	80mm	4mm	12mm

Servo or stepper motors are available.

COLUMN LOAD

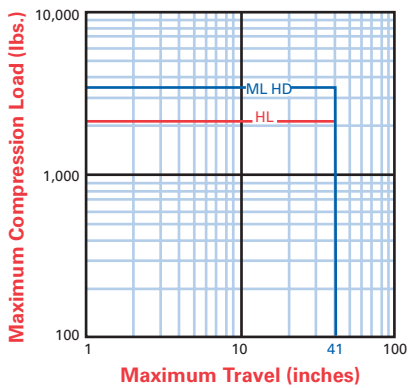

CRITICAL SPEED

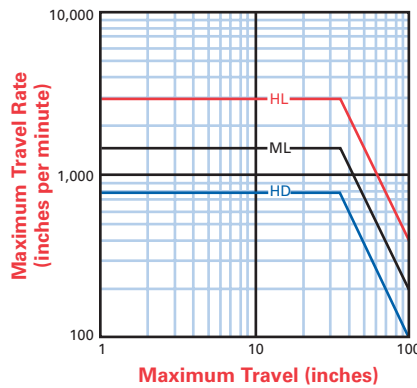

LIFE EXPECTANCY

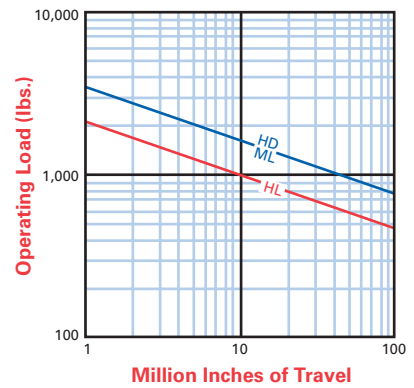

SERIES ILA-100 & ILAK-100

TRUNNION MOUNT PART NUMBER 9015-100

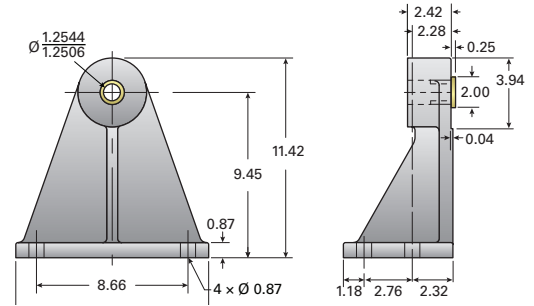

MODEL NUMBER	Max Load (lb)	Max Input Torque (in.-lb.)	Max Travel Rate (in./min)	Ball Screw Model Number	Torque per Lb. (in.-lb.)	Basic Weight (lb)	Dimensions			
							A	B	C	D
ILA-100 SL	2,500	830	3,750	1500-1875 SRT	0.332	89	4.00	2.50	16.00	19.00
ILA-100 HL	4,600	814	2,000	1500-1000 SRT	0.177	89	4.00	2.50	14.18	17.14
ILA-100 HD	9,000	756	946	1500-0473 SRT	0.084	89	4.00	2.50	14.18	17.14
ILAK-100 SL (keyed)	2,500	830	3,750	1500-1875 SRT	0.336	89	6.50	2.00	17.50	20.50
ILAK-100 HL (keyed)	4,600	814	2,000	1500-1000 SRT	0.179	89	6.50	2.00	14.18	17.14
ILAK-100 HD (keyed)	9,000	756	946	1500-0473 SRT	0.084	89	6.50	2.00	14.18	17.14

Total Weight = (2.08 lb) × Travel + Basic Weight

Rod Reaction Torque = Torque per lb. × Load

NOTE: Cylinder is self-lowering.

Input shaft must be secured to prevent rotation.

NOTE: Nook/Thomson ILA Series cylinders can be supplied with motor mounts. The sizes listed in the chart are mounts designed to match up to common motor faces. Application torque requirements and coupling size, style and attachment method will affect the size of the motor mount. See reference number pages 68 and 69 for motor mount/cylinder model availability. A custom motor mount can be manufactured to your specifications, please contact Nook/Thomson.

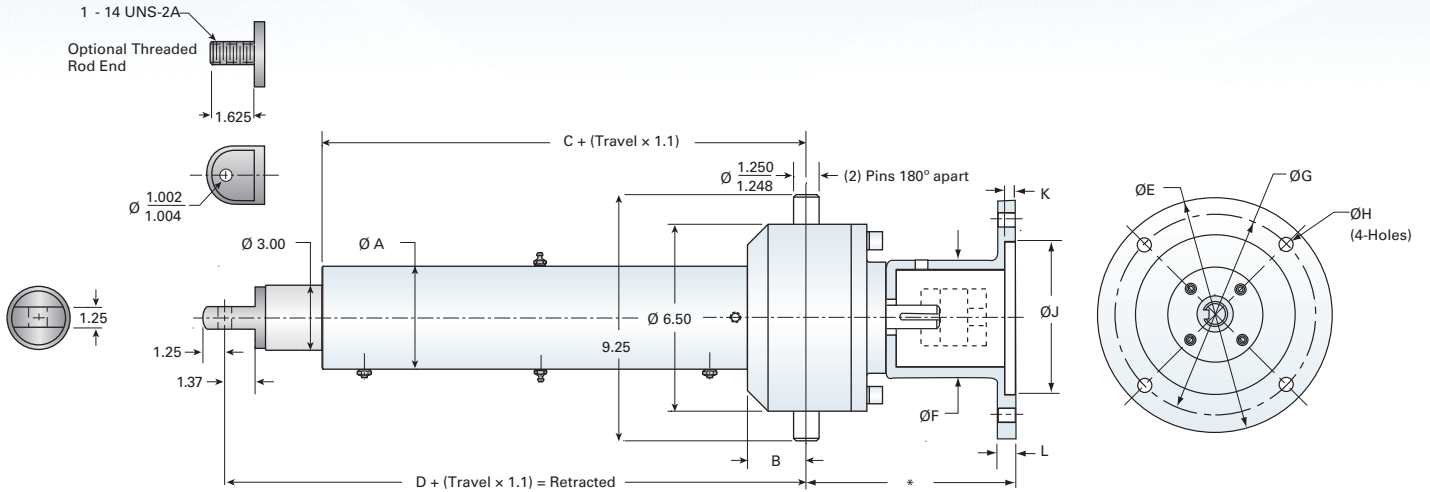

* Dimension based on motor mount. Contact factory with your specific requirements

Motor Frame	Frame Size	ØE	ØF	ØG	ØH	ØJ	K	L
NEMA	56C	6.75"	4.38"	5.88"	.41"	4.50"	.16"	.50"
NEMA	140TC	6.75"	4.38"	5.88"	.41"	4.50"	.16"	.50"
NEMA	180TC	9.25"	5.19"	7.25"	.56"	8.50"	.28"	.75"
IEC	80B5	200mm	96mm	165mm	11mm	130mm	4.5mm	12mm
IEC	80B14	120mm	96mm	100mm	7mm	80mm	4mm	12mm
IEC	90B5	200mm	116mm	165mm	11mm	130mm	4.5mm	12mm
IEC	90B14	140mm	116mm	115mm	9mm	95mm	4.5mm	12mm
IEC	100B5	250mm	116mm	215mm	13mm	180mm	5mm	14mm
IEC	100B14	160mm	116mm	130mm	9mm	110mm	5mm	14mm

Servo or stepper motors are available.

COLUMN LOAD

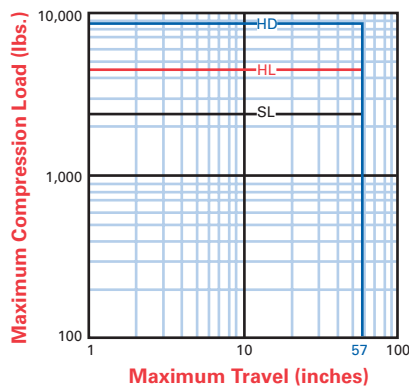

CRITICAL SPEED

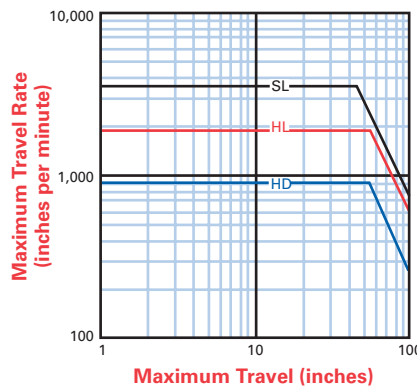

LIFE EXPECTANCY

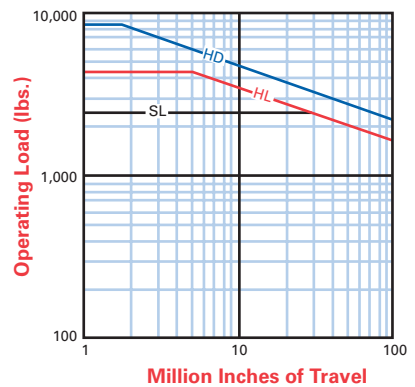

SERIES ILA-200 & ILAK-200

TRUNNION MOUNT PART NUMBER 9015-200

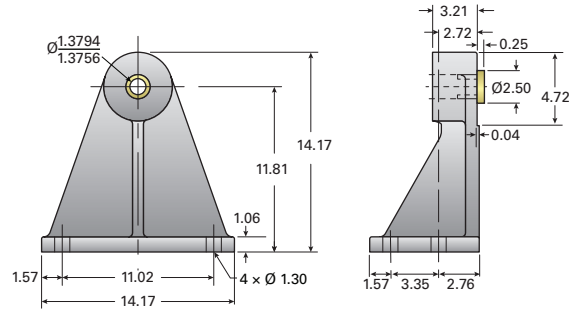

MODEL NUMBER	Maximum Load (lb)	Max Input Torque (in.-lb.)	Max Travel Rate (in/min)	Ball Screw Model Number	Torque per Lb. (in.-lb.)	Basic Weight (lb)	Dimensions
							A
ILA-200 HL	11,000	1,947	1,333	2250-1000 SRT	0.177	194	5.25
ILA-200-HD	21,000	1,848	667	2250-0500 SRT	0.088	194	5.25
ILAK-200 HL (Keyed)	11,000	1,947	1,337	2250-1000 SRT	0.178	194	7.50
ILAK-200 HD (Keyed)	21,000	1,848	667	2250-0500 SRT	0.088	194	7.50

Total Weight = (3.06 lb) × Travel + Basic Weight
 Rod Reaction Torque = Torque per lb. × Load

NOTE: Cylinder is self-lowering.
 Input shaft must be secured to prevent rotation.

NOTE: Nook/Thomson ILA Series cylinders can be supplied with motor mounts. The sizes listed in the chart are mounts designed to match up to common motor faces. Application torque requirements and coupling size, style and attachment method will affect the size of the motor mount. See reference number pages 68 and 69 for motor mount/cylinder model availability. A custom motor mount can be manufactured to your specifications, please contact Nook/Thomson.

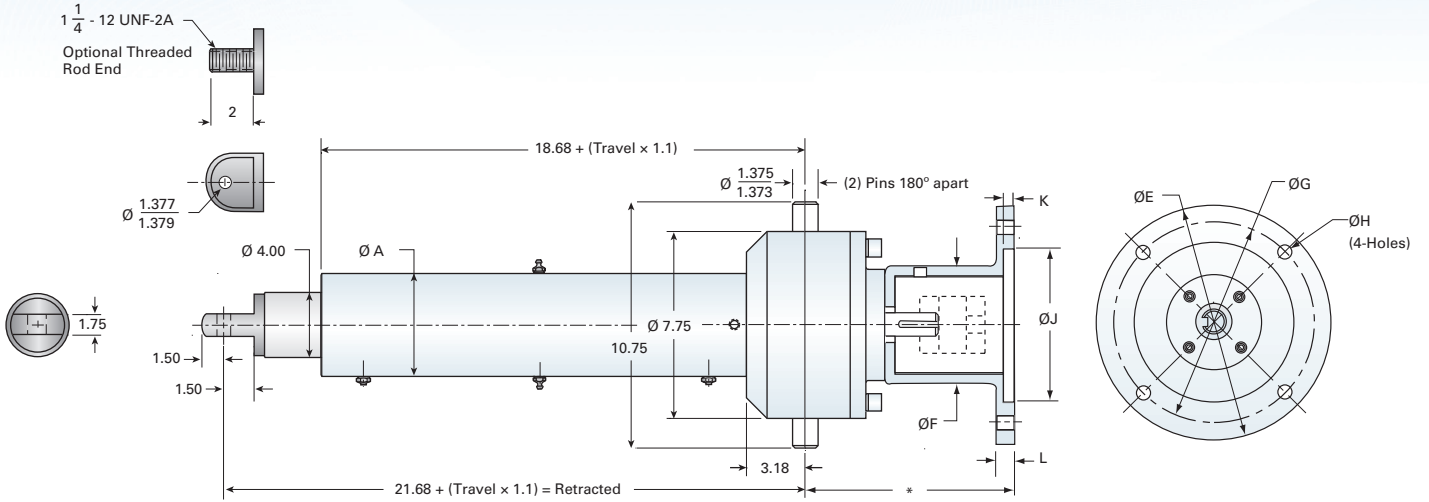

* Dimension based on motor mount. Contact factory with your specific requirements

Motor Frame	Frame Size	ØE	ØF	ØG	ØH	ØJ	K	L
NEMA	180TC	9.25"	5.19"	7.25"	.56"	8.50"	.28"	.75"
NEMA	213TC	8.88"	5.69"	7.25"	.56"	8.50"	.28"	.88"
IEC	100B5	250mm	134mm	215mm	13mm	180mm	5mm	14mm
IEC	100B14	160mm	134mm	130mm	9mm	110mm	5mm	14mm

Servo or stepper motors are available.

COLUMN LOAD

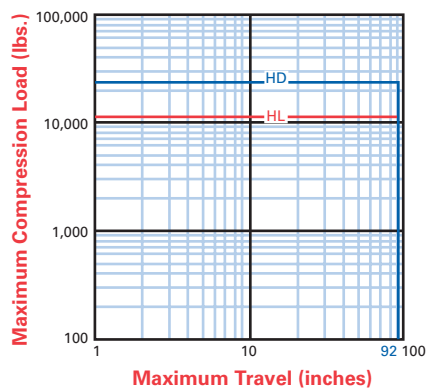

CRITICAL SPEED

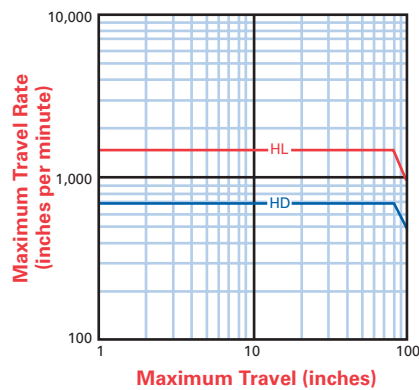

LIFE EXPECTANCY

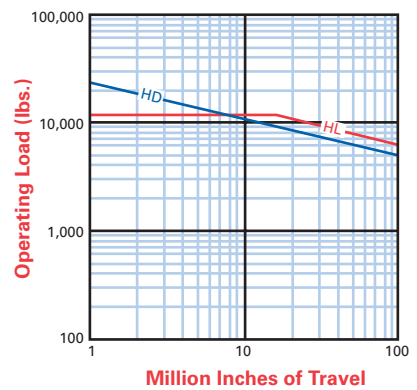

DD ELECTRIC CYLINDERS

DD Electric Cylinders are ruggedly designed and produced in standard models with thrust capacities from 500 lbs. to 40,000 lbs. DD Electric Cylinders feature a single reduction and are intended for use in industrial environments. They feature ground and hard chrome plated actuator tubes. The exterior surfaces feature industrial enamel paint. Epoxy paint is available on request.

These cylinders may be used individually or in multiple arrangements. Each Electric Cylinder is built to specification. For outdoor application of DD Electric Cylinders, contact Nook/Thomson Engineering for recommended alterations.



Nook/Thomson Electric Cylinders are used in many nautical applications.

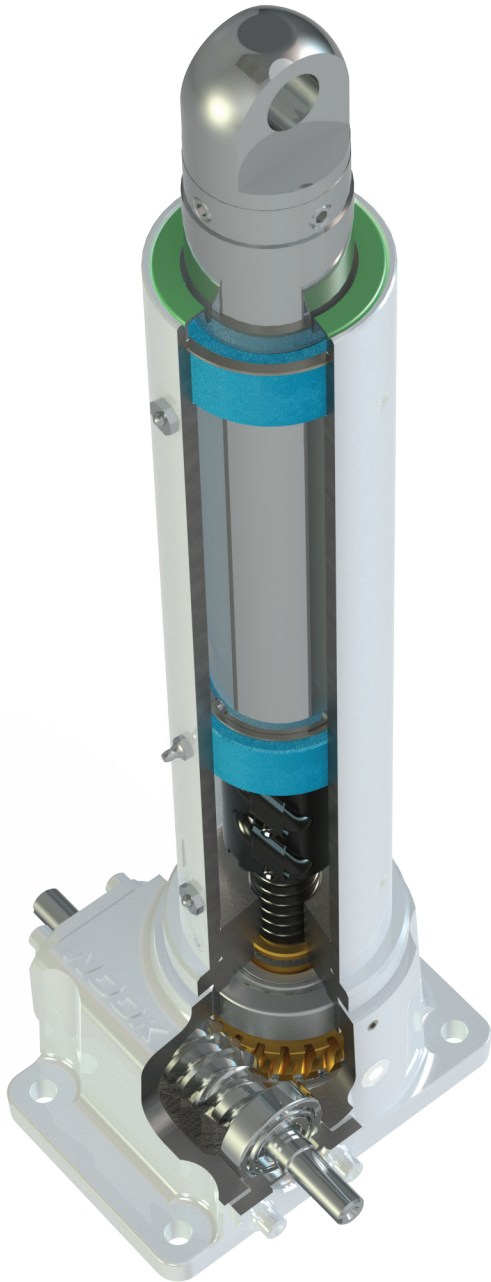

DD ELECTRIC CYLINDERS.....	34-37
Design Data	34-35
Quick Reference	36
Reference Number System	37

DD ELECTRIC CYLINDERS	
TECHNICAL DATA	38-51
Series DD-5.....	38-39
Series DD-10.....	40-41
Series DD-25.....	42-43
Series DD-30.....	44-45
Series DD-50.....	46-47
Series DD-100.....	48-49
Series DD-200.....	50-51

DD DESIGN DATA

BALL SCREW MODELS

	MODEL NUMBER	GEAR RATIO	SCREW SIZE	TURNS OF WORM PER INCH OF TRAVEL	TORQUE TO RAISE 1 LB (IN-LB)	MAX LOAD (LB)	MAX INPUT (HP)*
5 SERIES	DD - 55 - HL	5:1	0631-0500 SRT RA	10	0.0242	1,000	.33
	DD - 520 - HL	20:1	0631-0500 SRT RA	40	0.0102	1,000	.16
	DD - 55 - HD	5:1	0631-0200 SRT RA	25	0.0095	1,000	.33
	DD - 520 - H5	20:1	0631-0200 SRT RA	100	0.0040	1,000	.16
10 SERIES	DD - 105 - HL	5:1	0750-0500 SRT RA	10	0.0241	2,000	.5
	DD - 1020 - HL	20:1	0750-0500 SRT RA	40	0.0114	2,000	.25
	DD - 105 - HD	5:1	0750-0200 SRT RA	25	0.0095	2,000	.5
	DD - 1020 - HD	20:1	0750-0200 SRT RA	100	0.0045	2,000	.25
25 SERIES	DD - 256 - HL	6:1	1000-1000 SRT RA	6	0.0404	5,000	2
	DD - 2512 - HL	12:1	1000-1000 SRT RA	12	0.0244	5,000	1.5
	DD - 256 - ML	6:1	1000-0500 SRT RA	12	0.0201	5,000	2
	DD - 256 - HD	6:1	1000-0250 SRT RA	24	0.0102	5,000	2
	DD - 2512 - HD	12:1	1000-0250 SRT RA	48	0.0061	5,000	1.5
	DD - 2524 - HD	24:1	1000-0250 SRT RA	96	0.0042	5,000	.5
30 SERIES	DD - 306 - HD	6:1	1171-0413 SRT RA	14.53	0.0167	6,000	2
	DD - 3012 - HD	12:1	1171-0413 SRT RA	29.1	0.0169	6,000	1.5
	DD - 3024 - HD	24:1	1171-0413 SRT RA	58.10	0.0070	6,000	.5
50 SERIES	DD - 506 - SL	6:1	1500-1875 SRT RA	3.2	0.0726	10,000	3
	DD - 506 - HL	6:1	1500-1000 SRT RA	6	0.0387	10,000	3
	DD - 5024 - HL	24:1	1500-1000 SRT RA	24	0.0153	10,000	.75
	DD - 506 - HD	6:1	1500-0473 SRT RA	12.66	0.0183	10,000	3
	DD - 5024 - HD	24:1	1500-0473 SRT RA	50.66	0.0073	10,000	.75
100 SERIES	DD - 1008 - SL	8:1	1500-1875 SRT RA	4.26	0.0598	20,000	5
	DD - 1008 - HL	8:1	1500-1000 SRT RA	8	0.0319	20,000	5
	DD - 10024 - HL	24:1	1500-1000 SRT RA	24	0.0162	20,000	1.5
	DD - 1008 - HD	8:1	1500-0473 SRT RA	16.88	0.0151	20,000	5
	DD - 10024 - HD	24:1	1500-0473 SRT RA	50.66	0.0077	20,000	1.5
200 SERIES	DD - 2008 - HL	8:1	2250-1000 SRT RA	8	0.0313	40,000	7.5
	DD - 20024 - HL	24:1	2250-1000 SRT RA	24	0.0157	40,000	2.5
	DD - 2008 - HD	8:1	2250-0500 SRT RA	16	0.0157	40,000	7.5
	DD - 20024 - HD	24:1	2250-0500 SRT RA	48	0.0079	40,000	2.5

*Based on 35% Duty Cycle. Refer to page 10 for horsepower rating definitions.

DD DESIGN DATA
ACME SCREW MODELS

	MODEL NUMBER	GEAR RATIO	SCREW SIZE	TURNS OF WORM PER INCH OF TRAVEL	TORQUE TO RAISE 1 LB (IN-LB)	MAX LOAD (LB)	MAX INPUT (HP)*
5 SERIES	DD - 55 - A5	5:1	5/8"-5 RA	25	0.021	1,000	.33
	DD - 520 - A5	20:1	5/8"-5 RA	100	0.009	1,000	.16
	DD - 55 - A8	5:1	5/8"-8 RA	40	0.017	1,000	.33
	DD - 520 - A8	20:1	5/8"-8 RA	160	0.007	1,000	.16
	DD - 55 - A10	5:1	1/2"-10 RA	50	0.014	1,000	.33
	DD - 520 - A10	20:1	1/2"-10 RA	200	0.006	1,000	.16
10 SERIES	DD - 105 - A5	5:1	3/4"-5 RA	25	0.0225	2,000	.5
	DD - 1020 - A5	20:1	3/4"-5 RA	100	0.0125	2,000	.25
25 SERIES	DD - 256 - A2	6:1	1"-2 RA	12	0.0334	5,000	2
	DD - 256 - A4	6:1	1"-4 RA	24	0.0252	5,000	2
	DD - 2512 - A4	12:1	1"-4 RA	48	0.0148	5,000	1.5
	DD - 2524 - A4	24:1	1"-4 RA	96	0.0106	5,000	.5
30 SERIES	DD - 306 - A4	6:1	1 1/4"-4 RA	24	0.0271	6,000	2
	DD - 3012 - A4	12:1	1 1/4"-4 RA	48	0.0165	6,000	1.5
	DD - 3024 - A4	24:1	1 1/4"-4 RA	96	0.0118	6,000	.5
50 SERIES	DD - 506 - A2	6:1	1 1/2"-2 RA	12	0.0437	10,000	3
	DD - 506 - A3	6:1	1 1/2"-2 2/3 RA	16	0.0376	10,000	3
	DD - 5024 - A3	24:1	1 1/2"-2 2/3 RA	64	0.0144	10,000	.75
100 SERIES	DD - 1008 - A2	8:1	2"-2 RA	16	0.0377	20,000	5
	DD - 10024 - A2	24:1	2"-2 RA	48	0.0192	20,000	1.5
	DD - 1008 - A4	8:1	2"-4 RA	32	0.0314	20,000	5
	DD - 10024 - A4	24:1	2"-4 RA	96	0.0160	20,000	1.5
200 SERIES	DD - 2008 - A2	8:1	2 1/2"-2 RA	16	0.0435	40,000	7.5
	DD - 20024 - A2	24:1	2 1/2"-2 RA	48	0.0218	40,000	2.5
	DD - 2008 - A3	8:1	2 1/2"-3 RA	24	0.0394	40,000	7.5
	DD - 20024 - A3	24:1	2 1/2"-3 RA	72	0.0198	40,000	2.5

*Based on 25% Duty Cycle. Refer to page 10 for horsepower rating definitions.

QUICK REFERENCE

DD MODEL STANDARD WITH MOTORS

BALL SCREW CYLINDERS

MODEL NUMBER	DYNAMIC CAPACITY (lbf)	TRAVEL RATE (IN/MIN)
DD-105-HL / 05XX	750	172
DD-1020-HL / 02XX	800	43
DD-256-HL / 10XX	900	287
DD-506-SL / 20XX	950	539
DD-1008-SL / 20XX	1,150	404
DD-2524-HD / 03XX	1,500	18
DD-2512-HL / 10XX	1,500	144
DD-256-ML / 10XX	1,800	144
DD-256-HL / 20XX	1,800	288
DD-105-HD / 05XX	1,900	69
DD-1020-HD / 02XX	2,000	17
DD-2512-HD / 05XX	2,000	36
DD-256-HD / 07XX	2,000	72
DD-506-HL / 20XX	2,000	288
DD-1008-HL / 20XX	2,175	216
DD-3012-HD / 07XX	2,500	60
DD-306-HD / 15XX	2,500	120
DD-506-HL / 30XX	2,500	287
DD-3024-HD / 05XX	2,700	30
DD-10024-HL / 15XX	2,700	72
DD-306-HD / 15XX	3,275	120
DD-5024-HD / 07XX	3,400	34
DD-3012-HD / 10XX	3,600	60
DD-256-HD / 10XX	3,600	72
DD-256-ML / 20XX	3,600	144
DD-20024-HL / 20XX	4,000	72
DD-506-HD / 20XX	4,000	136
DD-2524-HD / 05XX	4,450	18
DD-2512-HD / 07XX	4,450	36
DD-1008-HD / 20XX	4,600	102
DD-1008-HL / 50XX	5,400	216
DD-506-HD / 30XX	5,750	136
DD-20024-HD / 20XX	7,000	36
DD-10024-HD / 15XX	7,150	34
DD-1008-HD / 30XX	7,500	102
DD-2008-HL / 75XX	8,000	216
DD-20024-HD / 30XX	10,000	36
DD-2008-HD / 50XX	11,000	108
DD-1008-HD / 50XX	12,000	102
DD-2008-HD / 75XX	16,600	106

ACME SCREW CYLINDERS

MODEL NUMBER	DYNAMIC CAPACITY (lbf)	TRAVEL RATE (in/min)
DD-105-A5 / 02XX	850	69
DD-1020-A5 / 02XX	900	17
DD-506-A3 / 10XX	1,000	108
DD-3024-A4 / 05XX	1,200	18
DD-256-A2 / 15XX	1,725	144
DD-2524-A4 / 05XX	1,880	18
DD-5024-A3 / 07XX	1,900	27
DD-506-A2 / 20XX	1,900	144
DD-10024-A2 / 15XX	2,000	36
DD-1008-A4 / 20XX	2,000	54
DD-1008-A2 / 20XX	2,000	108
DD-306-A4 / 15XX	2,100	72
DD-3012-A4 / 10XX	2,200	36
DD-506-A3 / 20XX	2,200	108
DD-256-A4 / 15XX	2,280	72
DD-2512-A4 / 10XX	2,500	36
DD-20024-A2 / 20XX	2,500	36
DD-506-A3 / 30XX	2,900	108
DD-508-A4 / 20XX	3,000	54
DD-1008-A2 / 30XX	3,000	108
DD-20024-A2 / 30XX	3,500	36
DD-2008-A2 / 75XX	4,250	108
DD-1008-A2 / 50XX	4,500	108
DD-2008-A3 / 75XX	4,620	72

XX = motor specification, see page 70

REFERENCE NUMBER SYSTEM

DD-2512-HL / 10RT-1 / 2CA-4C / CC / 24.5 / ERS

SERIES DD MODEL

Refer to pages 34 to 35 for available models.

SHAFT ORDER CODE

10RT - 1

CCW Position 1, 3, 5, 7
CW Position 2, 4, 6, 8

ORDER CODES (Must Include a Position)

NOTE: Both Shaft Extensions Must Be Specified.

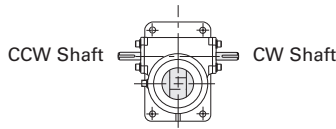

NO ACCESSORY

- SSE- = Standard Shaft Extension, Position 1 or 2
- 000- = Delete Shaft Extension, Position 1 or 2
- SPC- = Special Modified Shaft Extension, Position 1 or 2

Motor Mounts Without Motor

Position 1 or 2
See page 70 for standard motor mount order codes.

Motor Mounts With Motors

Position 1 or 2
See page 70 & 72 for available motors.

Rotary Limit Switch

Position 1 C or E through 8 C or E
See page 74 - 75 for available rotary limit switches.

NOTE: A Limit Switch must specify a close or extended mount.

Compact Limit Switch

Position 1 through 8
See page 76 - 77 for available compact limit switches.

HOUSING CONFIGURATION

- F = Standard Flange Base
- C = Clevis Base
- R = Clevis Base Rotated 90°

SCREW CONFIGURATION

- T = Threaded End
- C = Clevis End
- D = Threaded rod end with female clevis installed
- P = Top Plate

TRAVEL

Travel in inches.

MODIFIER LIST

- E, B, and/or R
- E = In-Line Encoder (See p. 73)
- B = Bellows Boots (See p. 85)
- R = Rod Type Limit Switch (See p. 78)
- Optional S or M Required
- S = Standard, no additional description required
- M = Modified, additional description required

NOTE: NOT ALL OPTIONS AVAILABLE FOR ALL SIZES



Nook/Thomson Electric Cylinders are used extensively in military applications.

SERIES DD-5

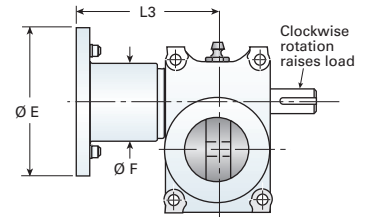

	MODEL NUMBER	Dynamic Capacity (lbf)	Screw Rated Life (in. × 10 ⁶)	Max. Motor HP Rating (ref)	Max Rod Reaction Torque (in.-lb.)
Ball Screw	DD-55-HL / T03XX	1,000	13.5	.33	89
	DD-520-HL / T06XX	1,000	1.69	.16	89
	DD-55-HD / T03XX	1,000	2.91	.33	35
	DD-520-HD / T06XX	1,000	9.9	.16	35
Acme Screw	DD-55-A5 / T03XX	1,000	—	.33	72
	DD-55-A8 / T03XX	1,000	—	.33	58
	DD-55-A10 / T03XX	1,000	—	.33	53
	DD-520-A5 / T06XX	1,000	—	.16	72
	DD-520-A8 / T06XX	1,000	—	.16	58
	DD-520-A10 / T06XX	1,000	—	.16	53

For "XX", see page 70 for motor options. Standard motor referenced is a 1750 rpm AC brakemotor.

LIFE EXPECTANCY

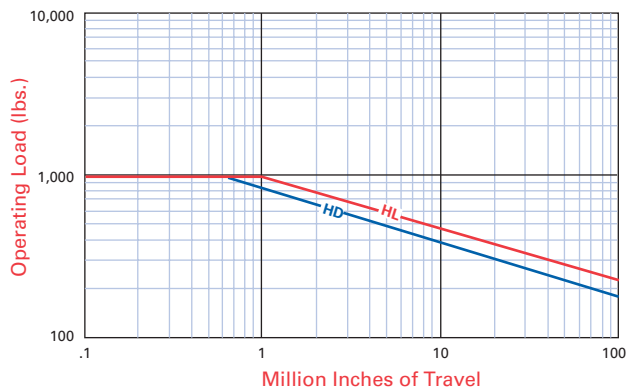

COLUMN LOAD

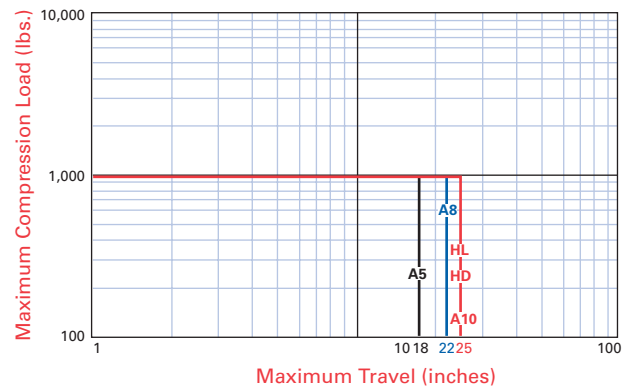

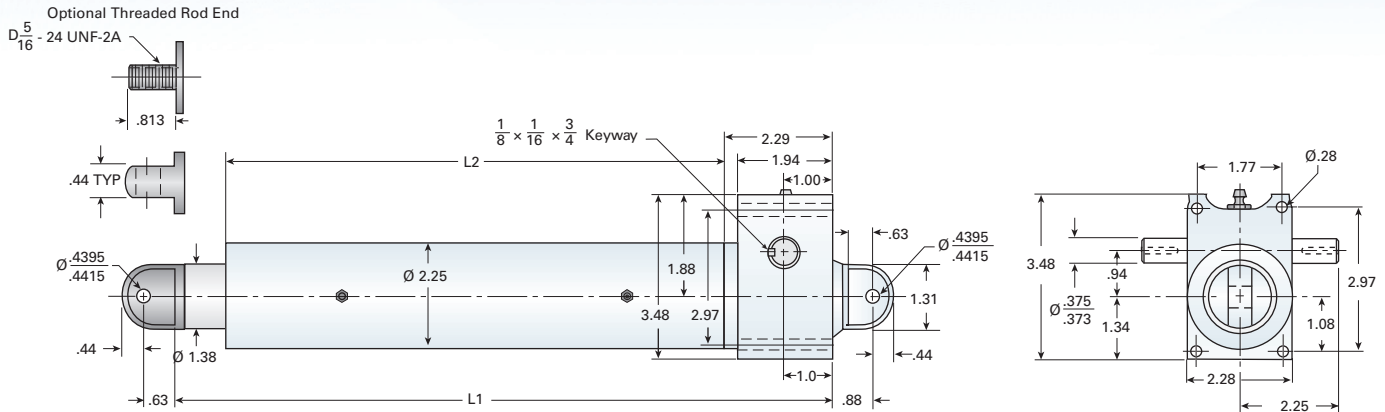

Basic Weight (lb)*	Basic Length (L1) (in)**	Basic Length (L2) (in)**
12	8.06	5.00
12	8.06	5.00
12	8.06	5.00
12	8.06	5.00
11	7.38	3.88
11	7.38	3.88
11	7.38	3.88
11	7.38	3.88
11	7.38	3.88
11	7.38	3.88

NEMA FRAME SIZE

NEMA FRAME SIZE	ØE	ØF	L3
42	4.63	2.69	4.48
48	4.63	3.12	4.48

Servo or stepper motors are available.
Custom motor / gearbox adapters are also available.

- * Ball Screw Models: Total Weight = (0.97 lb) × Travel + Basic Weight
- * Acme Screw Models: Total Weight = (0.98 lb) × Travel + Basic Weight

** Total Length = Basic length + Travel × 1.25

Base clevis is shown in standard orientation but may be rotated 90° or per customer specification. May also be ordered with optional flange base.

Motor mount is shown in Position 1 - it may be mounted to either side of the cylinder (see page 68).

WARNING: Units are not to be used as personnel support or movement. Ball Screw Models are self-lowering.

SERIES DD-10

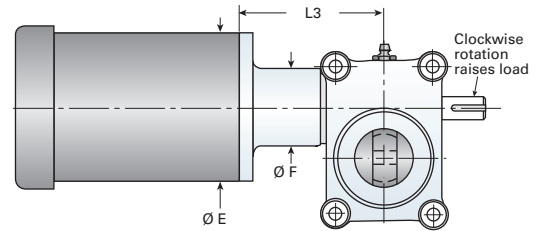

	MODEL NUMBER	Travel Rate (in/min)	Dynamic Capacity (lbf)	Screw Rated Life (in × 10 ⁶)	Std. Motor HP Rating (ref.)	Std. Brake Torque (ft-lb)
Ball Screw	DD-105-HL / 05XX	173	750	46	.50	3
	DD-1020-HL / 02XX	43	800	39	.25	3
	DD-105-HD / 05XX	69	1900	1.5	.50	3
	DD-1020-HD / 02XX	17	2000	1.3	.25	3
Acme Screw	DD-105-A5 / 05XX	69	850	—	.50	3
	DD-1020-A5 / 02XX	17	900	—	.25	3

For "XX", see page 70 for motor options. Standard motor referenced is a 1750 rpm AC brakemotor.

LIFE EXPECTANCY

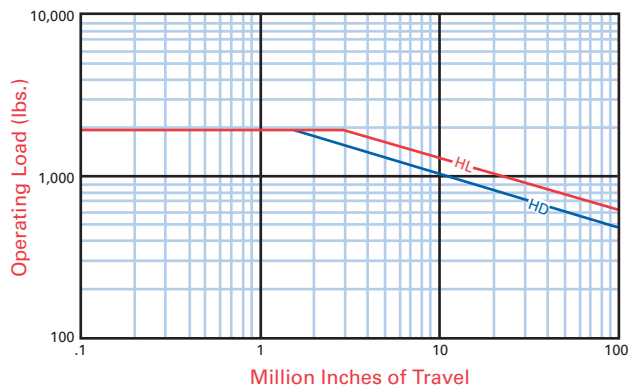

COLUMN LOAD

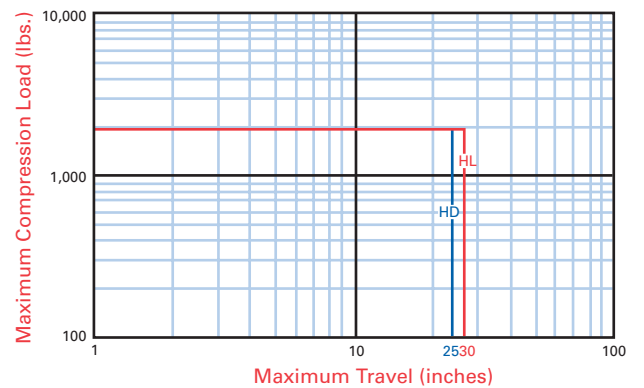

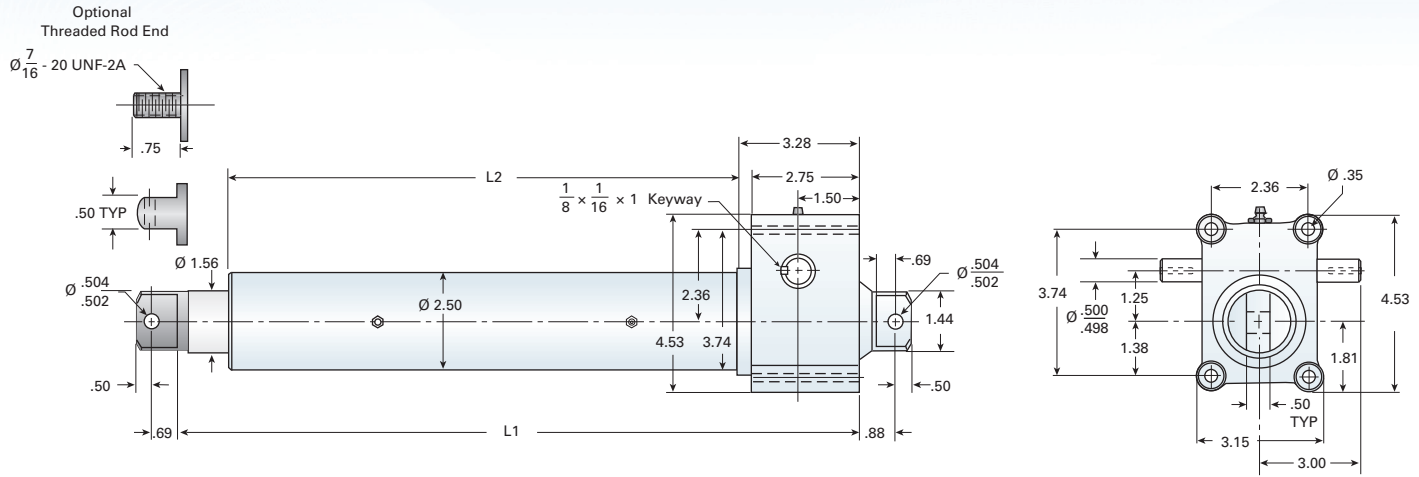

Approx Stopping Distance (in)		Max Rod Reaction Torque (in lb)	Basic Weight (lb)*	Basic Length (L1) (in)**	Basic Length (L2) (in)**
No Load	Full Load				
.20	.38	67	19	10.75	6.38
.80	.15	71	19	10.75	6.38
.05	.06	67	19	10.75	6.38
.02	.02	71	19	10.75	6.38
.08	—	79	15	8.25	4.25
.02	—	71	15	8.25	4.25

NEMA FRAME SIZE	ØE (in)	ØF (in)	L3 (in)	HP
42	4.63	2.69	4.48	—
48	4.63	3.12	4.48	—
56	6.63	3.75	5.71	¼ - ½

Servo or stepper motors are available. Custom motor / gearbox adapters are also available.

* Ball Screw Models: Total Weight = (1.10 lb) × Travel + Basic Weight
 * Acme Screw Models: Total Weight = (1.10 lb) × Travel + Basic Weight
 ** Total Length = Basic length + Travel × 1.25

Base clevis is shown in standard orientation but may be rotated 90° or per customer specification. May also be ordered with optional flange base. Motor is shown in Position 1 - it may be mounted to either side of the cylinder (see page 68).

For motor dimensions, please visit www.nookindustries.com.

WARNING: Units are not to be used as personnel support or movement. Ball Screw Models are self-lowering.



SERIES DD-25

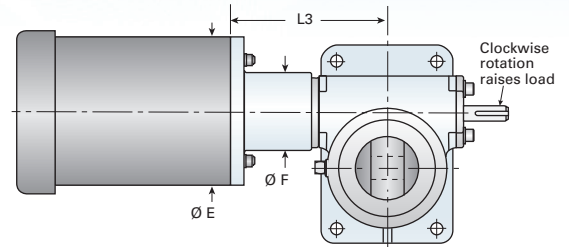

	MODEL NUMBER	Travel Rate (in/min)	Dynamic Capacity (lbf)	Screw Rated Life (in × 106)	Std. Motor HP Rating (ref.)	Std. Brake Torque (ft-lb)
Ball Screw	DD-256-HL / 10XX	288	900	13.5	1	6
	DD-256-HL / 20XX	288	1,800	1.69	2	10
	DD-2512-HL / 10XX	144	1,500	2.91	1	6
	DD-256-ML / 15XX	144	1,800	7	1.5	6
	DD-256-ML / 20XX	144	3,600	.9	2	10
	DD-256-HD / 10XX	72	3,600	.09	1	6
	DD-256-HD / 07XX	72	2,000	4.1	.75	6
	DD-2512-HD / 07XX	36	4,450	.38	.75	6
	DD-2512-HD / 05XX	36	2,000	4.1	.5	3
	DD-2524-HD / 05XX	18	4,450	.38	.5	3
	DD-2524-HD / 03XX	18	1,500	9.9	.33	3
Acme Screw	DD-256-A2 / 15XX	144	1,725	—	1.5	6
	DD-256-A4 / 15XX	72	2,280	—	1.5	6
	DD-2512-A4 / 07XX	36	1,900	—	.75	6
	DD-2512-A4 / 10XX	36	2,500	—	1	6
	DD-2524-A4 / 05XX	18	1,880	—	.5	3

For "XX", see page 70 for motor options. Standard motor referenced is a 1750 rpm AC brakemotor.

LIFE EXPECTANCY

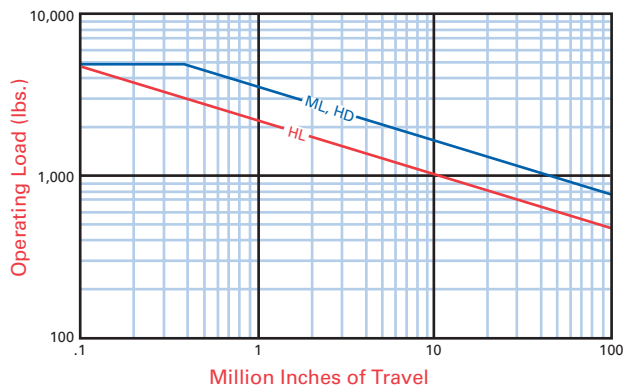

COLUMN LOAD

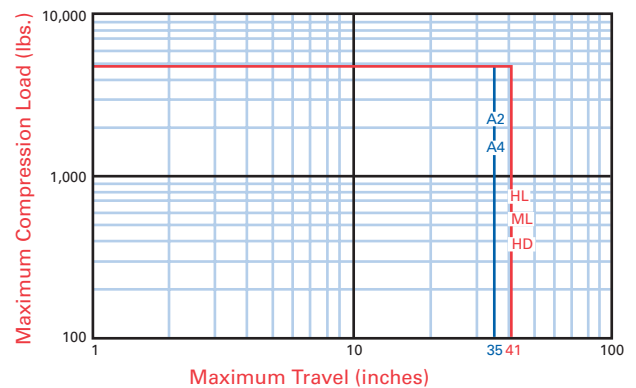

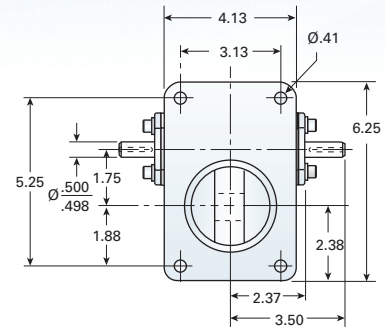
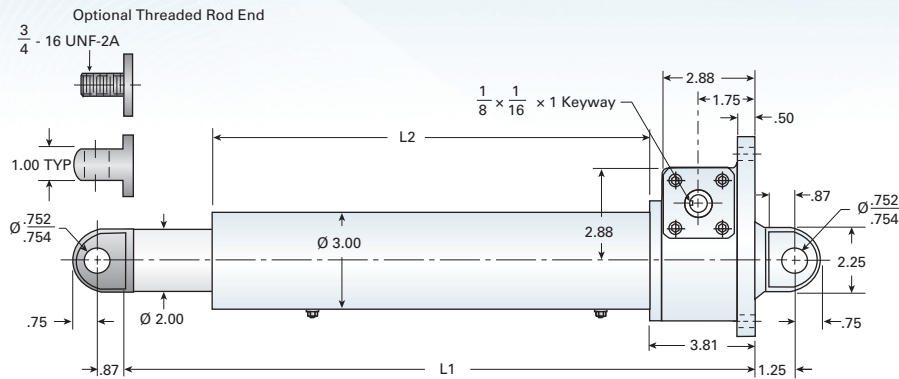

Approx Stopping Distance (In)		Max Rod Reaction Torque (in lb)	Basic Weight (lb)*	Basic Length (L1) (in)**	Basic Length (L2) (in)**
No Load	Full Load				
.26	.44	159	33	12.44	7.13
.43	.74	318	33	12.44	7.13
.25	.35	265	33	12.44	7.13
.25	.43	159	33	12.44	7.13
.21	.42	318	33	12.44	7.13
.12	.21	159	33	12.44	7.13
.06	.09	89	33	12.44	7.13
.03	.04	197	33	12.44	7.13
.04	.06	89	33	12.44	7.13
.02	.03	197	33	12.44	7.13
.02	.02	66	33	12.44	7.13
.30	—	240	30	10.38	4.75
.15	—	239	30	10.38	4.75
.06	—	197	30	10.38	4.75
.06	—	263	30	10.38	4.75
.02	—	197	30	10.38	4.75

NEMA FRAME SIZE

	ØE (in)	ØF (in)	L3 (in)	HP
56C	6.62	3.5	6.25	1/4 - 2

Servo or stepper motors are available.

Custom motor / gearbox adapters are also available.

* Ball Screw Models: Total Weight = (1.49 lb) × Travel + Basic Weight

* Acme Screw Models: Total Weight = (1.49 lb) × Travel + Basic Weight

** Total Length = Basic length + (Travel × 1.25)

Base clevis is shown in standard orientation but may be rotated 90° or per customer specification. May also be ordered with optional flange base. Motor is shown in Position 1 - it may be mounted to either side of the cylinder (see page 68).

For motor dimensions, please visit www.nookindustries.com.

WARNING: Units are not to be used as personnel support or movement. Ball Screw Models are self-lowering.

SERIES DD-30

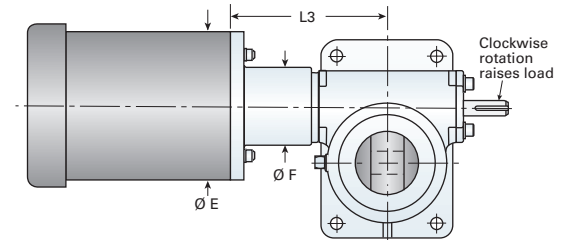

	MODEL NUMBER	Travel Rate (in/min)	Dynamic Capacity (lbf)	Screw Rated Life (in × 10 ⁶)	Std. Motor HP Rating (ref.)	Std. Brake Torque (ft-lb)
Ball Screw	DD-306-HD / 15XX	120	3,275	1.68	1.5	6
	DD-3012-HD / 10XX	60	3,600	1.26	1.0	6
	DD-3012-HD / 07XX	60	2,500	3.78	.75	6
	DD-3024-HD / 05XX	30	2,700	3.00	.5	3
Acme Screw	DD-306-A4 / 15XX	72	2,100	—	1.5	6
	DD-3012-A4 / 10XX	36	2,200	—	1	6
	DD-3024-A4 / 05XX	18	1,200	—	.5	3

For "XX", see page 70 for motor options. Standard motor referenced is a 1750 rpm AC brakemotor.

LIFE EXPECTANCY

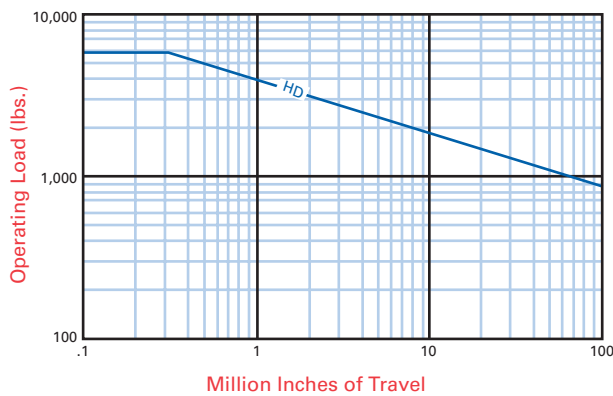

COLUMN LOAD

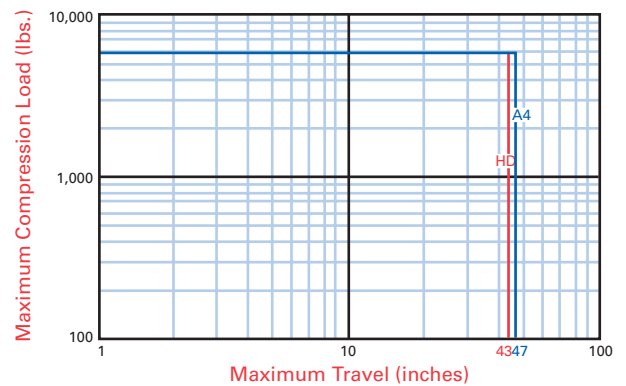

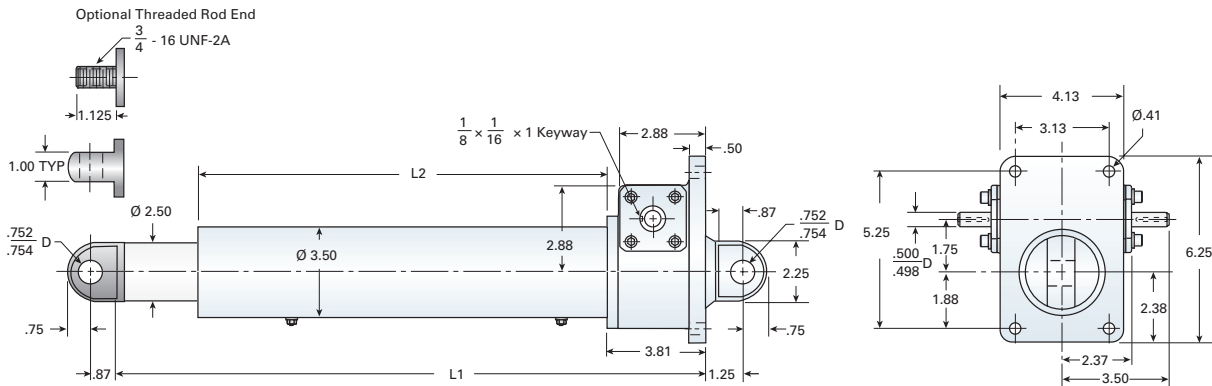

Approx Stopping Distance (In)		Max Rod Reaction Torque (in lb)	Basic Weight (lb)*	Basic Length (L1) (in)**	Basic Length (L2) (in)**
No Load	Full Load				
.25	.83	239	38	12.44	7.31
.10	.16	263	38	12.44	7.31
.05	.07	183	38	12.44	7.31
.03	.05	197	38	12.44	7.31
.15	—	240	33	10.50	5.13
.06	—	263	33	10.50	5.13
.02	—	140	33	10.50	5.13

NEMA FRAME SIZE	ØE (in)	ØF (in)	L3 (in)	HP
56C	6.62	3.50	6.25	1/4 - 2

Servo or stepper motors are available.

Custom motor / gearbox adapters are also available.

* Ball Screw Models: Total Weight = (1.91 lb) × Travel + Basic Weight

* Acme Screw Models: Total Weight = (1.95 lb) × Travel + Basic Weight

** Total Length = Basic length + (Travel × 1.25)

Base clevis is shown in standard orientation but may be rotated 90° or per customer specification. May also be ordered with optional flange base. Motor is shown in Position 1 - it may be mounted to either side of the cylinder (see page 68).

For motor dimensions, please visit www.nookindustries.com.

WARNING: Units are not to be used as personnel support or movement. Ball Screw Models are self-lowering.

SERIES DD-50

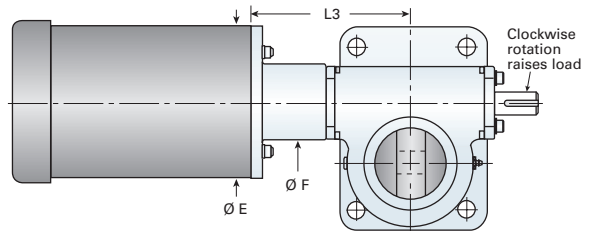

	MODEL NUMBER	Travel Rate (in/min)	Dynamic Capacity (lbf)	Screw Rated Life (in x 106)	Std. Motor HP Rating (ref.)	Std. Brake Torque (ft-lb)
Ball Screw	DD-506-SL / 20XX	539	950	110	2	10
	DD-506-HL / 20XX	288	2,000	73	2	10
	DD-506-HL / 30XX	288	2,500	21	3	15
	DD-506-HD / 20XX	136	3,500	18	2	10
	DD-506-HD / 30XX	136	5,750	5.4	3	15
	DD-5024-HD / 07XX	34	3,000	19	0.75	6
Acme Screw	DD-506-A2 / 20XX	144	1,900	—	2	10
	DD-506-A3 / 10XX	108	1,000	—	1	6
	DD-506-A3 / 20XX	108	2,200	—	2	10
	DD-506-A3 / 30XX	108	2,900	—	3	15
	DD-508-A4 / 20XX	54	3,000	—	2	15
	DD-5024-A3 / 07XX	27	1,900	—	.75	6

For "XX", see page 70 for motor options. Standard motor referenced is a 1750 rpm AC brakemotor.

LIFE EXPECTANCY

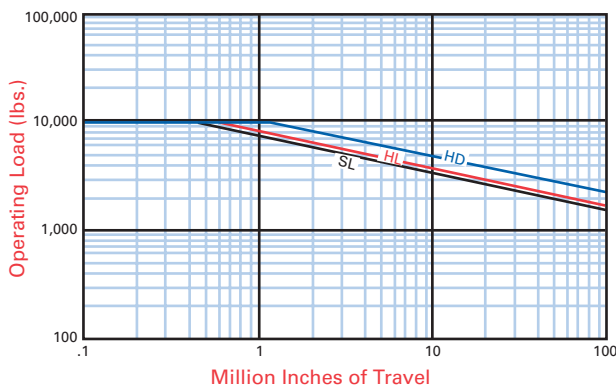

COLUMN LOAD

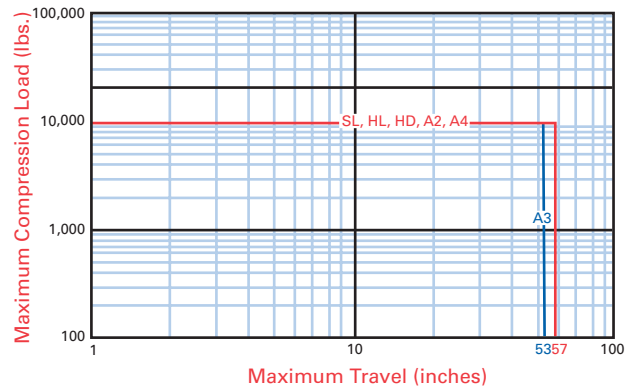

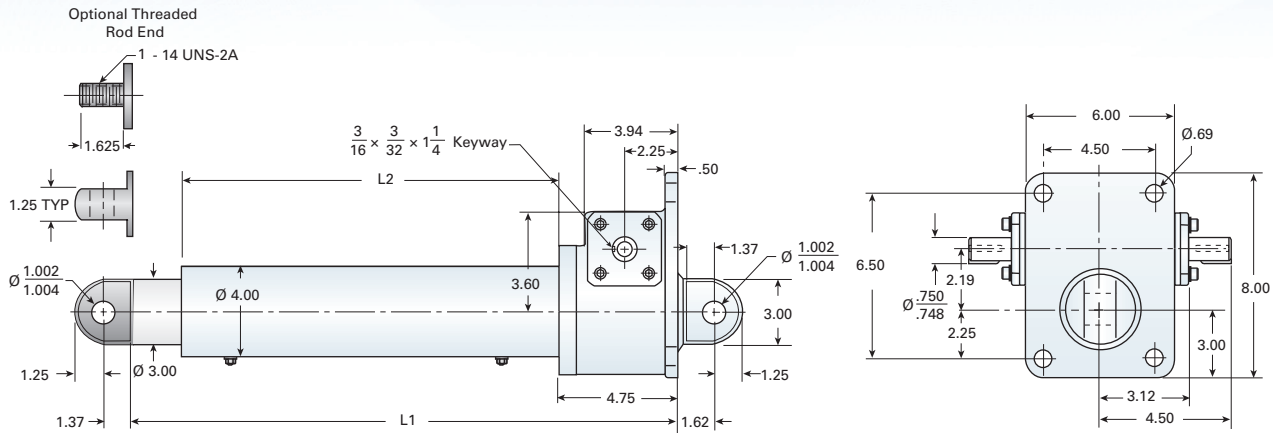

Approx Stopping Distance (In)		Max Rod Reaction Torque (in lb)	Basic Weight (lb)*	Basic Length (L1) (in)**	Basic Length (L2) (in)**
No Load	Full Load				
.8	1.7	1.7	63	15.56	9.56
.43	1.07	1.07	63	15.33	8.88
.74	1.48	1.48	63	15.33	8.88
.20	.46	.46	63	15.33	8.88
.35	.66	.66	63	15.33	8.88
.03	.04	.04	63	15.33	8.88
.21	—	476	53	12.38	6.06
.19	—	143	53	12.38	6.06
.16	—	288	53	12.38	6.06
.28	—	432	53	12.38	6.06
.08	—	455	53	12.38	6.06
.02	—	285	53	12.38	6.06

NEMA FRAME SIZE	ØE (in)	ØF (in)	L3 (in)	HP
56C	6.75	3.75	7.25	¾ - 2
182TC	9.25	3.75	8.00	3

Servo or stepper motors are available.

Custom motor / gearbox adapters are also available.

* Ball Screw Models: Total Weight = (2.28 Lb) × Travel + Basic Weight

* Acme Screw Models: Total Weight = (2.28 Lb) × Travel + Basic Weight

** Total Length = Basic length + (Travel × 1.25)

Base clevis is shown in standard orientation but may be rotated 90° or per customer specification. May also be ordered with optional flange base. Motor is shown in Position 1 - it may be mounted to either side of the cylinder (see page 68).

For motor dimensions, please visit www.nookindustries.com.

WARNING: Units are not to be used as personnel support or movement. Ball Screw Models are self-lowering.

SERIES DD-100

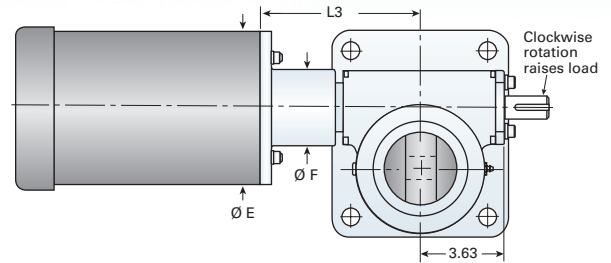

	MODEL NUMBER	Travel Rate (in/min)	Dynamic Capacity (lbf)	Screw Rated Life (in × 10 ⁶)	Std. Motor HP Rating (ref.)	Std. Brake Torque (ft-lb)
Ball Screw	DD-1008-SL / 20XX	404	1,150	240	2	10
	DD-1008-HL / 20XX	216	2,175	42	2	10
	DD-1008-HL / 50XX	216	5,400	2.7	5	15
	DD-1008-HD / 20XX	102	4,600	10.4	2	10
	DD-1008-HD / 30XX	102	7,500	2.4	3	15
	DD-1008-HD / 50XX	102	12,000	.59	5	15
	DD-10024-HL / 15XX	72	2,700	22	1.5	6
	DD-10024-HD / 15XX	34	7,150	2.8	1.5	6
Acme Screw	DD-1008-A2 / 20XX	108	2,000	—	2	10
	DD-1008-A2 / 30XX	108	3,000	—	3	15
	DD-1008-A2 / 50XX	108	4,500	—	5	15
	DD-1008-A4 / 20XX	54	2,000	—	2	10
	DD-10024-A2 / 15XX	36	2,000	—	1.5	6

For "XX," see page 70 for motor options. Standard motor referenced is a 1750 rpm AC brakemotor.

LIFE EXPECTANCY

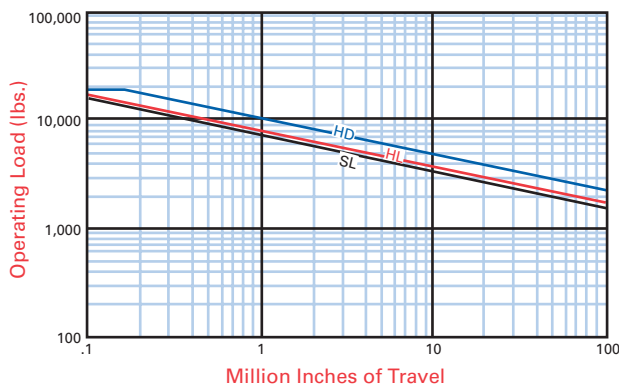

COLUMN LOAD

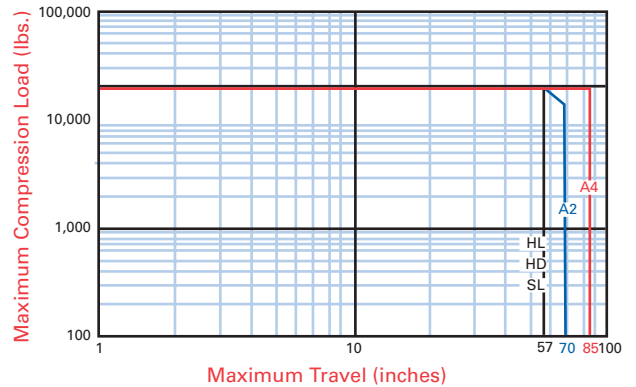

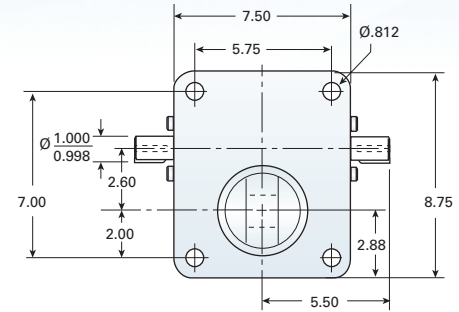
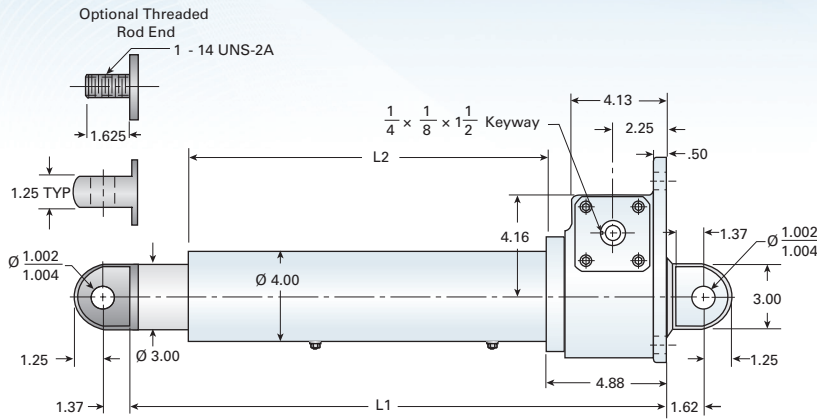

Approx Stopping Distance (In)		Max Rod Reaction Torque (in lb)	Basic Weight (lb)*	Basic Length (L1) (in)**	Basic Length (L2) (in)**
No Load	Full Load				
.6	.9	385	80	15.25	8.88
.3	.5	385	80	15.25	8.88
.7	1.3	956	80	15.25	8.88
.2	.2	385	80	15.25	8.88
.3	.4	628	80	15.25	8.88
.3	.7	1005	80	15.25	8.88
.15	.16	478	80	15.25	8.88
.07	.09	598	80	15.25	8.88
.6	—	398	77	12.88	6.50
.3	—	597	77	12.88	6.50
.7	—	896	77	12.88	6.50
.2	—	362	77	12.88	6.50
.3	—	398	77	12.88	6.50

NEMA FRAME SIZE

	ØE (in)	ØF (in)	L3 (in)	HP
56C	6.75	4.38	8.25	1 - 2
184TC	9.25	4.38	9.00	3 - 5

Servo or stepper motors are available.
Custom motor / gearbox adapters are also available.

* Ball Screw Models: Total Weight = (2.28 lb) × Travel + Basic Weight
* Acme Screw Models: Total Weight = (2.68 lb) × Travel + Basic Weight

** Total Length = Basic length + (T × 1.25)

Base clevis is shown in standard orientation but may be rotated 90° or per customer specification. May also be ordered with optional flange base. Motor is shown in Position 1 - it may be mounted to either side of the cylinder (see page 68).

For motor dimensions, please visit www.nookindustries.com.

WARNING: Units are not to be used as personnel support or movement. Ball Screw Models are self-lowering.

SERIES DD-200

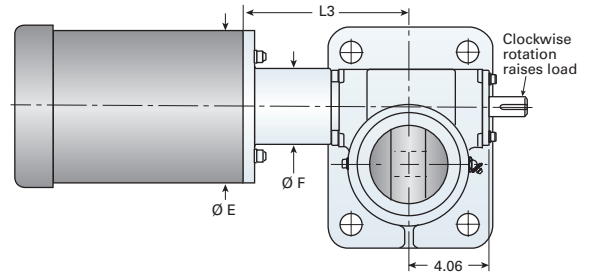

	MODEL NUMBER	Travel Rate (in/min)	Dynamic Capacity (lbf)	Screw Rated Life (in × 106)	Std. Motor HP Rating (ref.)	Std. Brake Torque (ft-lb)
Ball Screw	DD-2008-HL / 75XX	216	8,000	36	7.5	25
	DD-2008-HD / 75XX	108	16,600	2.1	7.5	25
	DD-2008-HD / 50XX	108	11,000	7.3	5	15
	DD-20024-HL / 20XX	72	4,000	292	2	10
	DD-20024-HD / 20XX	36	7,000	28	2	10
	DD-20024-HD / 30XX	36	10,000	9.7	3	15
Acme Screw	DD-2008-A2 / 70XX	108	4,250	—	7.5	15
	DD-2008-A3 / 70XX	72	4,620	—	7.5	15
	DD-20024-A2 / 20XX	36	2,500	—	2	10
	DD-20024-A2 / 30XX	36	3,500	—	3	15

For "XX," see page 70 for motor options. Standard motor referenced is a 1750 rpm AC brakemotor.

LIFE EXPECTANCY

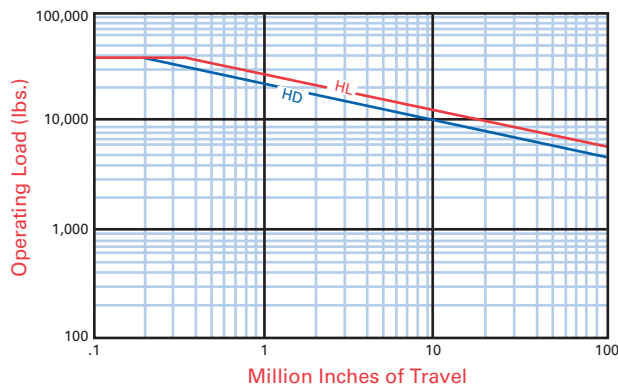

COLUMN LOAD

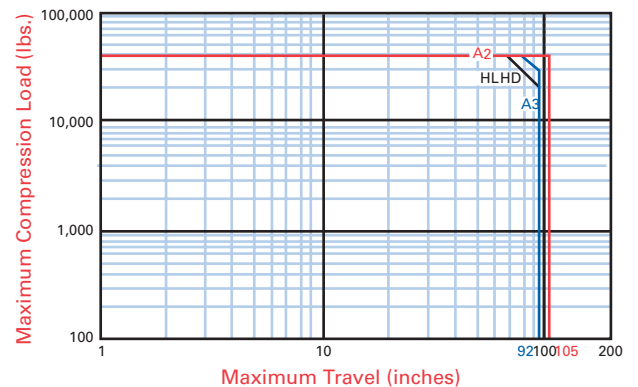

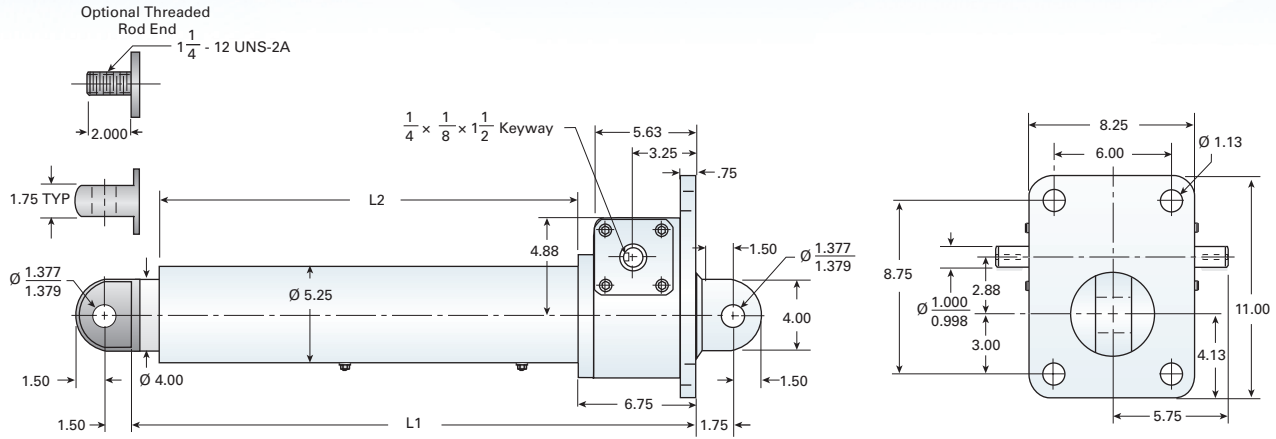

Approx Stopping Distance (In)		Max Rod Reaction Torque (in lb)	Basic Weight (lb)*	Basic Length (L1) (in)**	Basic Length (L2) (in)**
No Load	Full Load				
.4	.6	1,416	154	21.13	12.63
.2	.3	1,469	154	21.13	12.63
.4	.7	979	154	21.13	12.63
.1	.1	708	154	21.13	12.63
.1	.1	620	154	21.13	12.63
.1	.1	885	154	21.13	12.63
.4	—	995	138	17.44	8.94
.24	—	979	138	17.44	8.94
.05	—	585	138	17.44	8.94
.09	—	819	138	17.44	8.94

NEMA FRAME SIZE	ØE (in)	ØF (in)	L3 (in)	HP
56C	6.75	5.19	8.65	2
184TC	9.25	5.19	9.00	3 - 5
213TC	9.25	5.69	9.65	7.5

Servo or stepper motors are available.
Custom motor / gearbox adapters are also available.

* Ball Screw Models: Total Weight = (3.36 lb) × Travel + Basic Weight
* Acme Screw Models: Total Weight = (3.65 lb) × Travel + Basic Weight

** Total Length = Basic length + Travel × 1.25

Base clevis is shown in standard orientation but may be rotated 90° or per customer specification. May also be ordered with optional flange base. Motor is shown in Position 1 - it may be mounted to either side of the cylinder (see page 68). For motor dimensions, please visit www.nookindustries.com.

WARNING: Units are not to be used as personnel support or movement. Ball Screw Models are self-lowering.

RAD ELECTRIC CYLINDERS

RAD Electric Cylinders incorporate the same benefits as DD Electric Cylinders, including the rugged design and capacities from 3,500 lbs. to 40,000 lbs. RAD Electric Cylinders include a second reduction giving a reduced input torque and lower travel rate. RAD Electric Cylinders also feature ground and hard chrome plated actuator tubes. The exterior surfaces feature industrial enamel paint. Epoxy paint is available on request.

These cylinders may be used individually or in multiple arrangements with DD Electric Cylinders. Each Electric Cylinder is built to specification. For outdoor application of RAD Electric Cylinders, contact Nook/Thomson Engineering for recommended alterations.

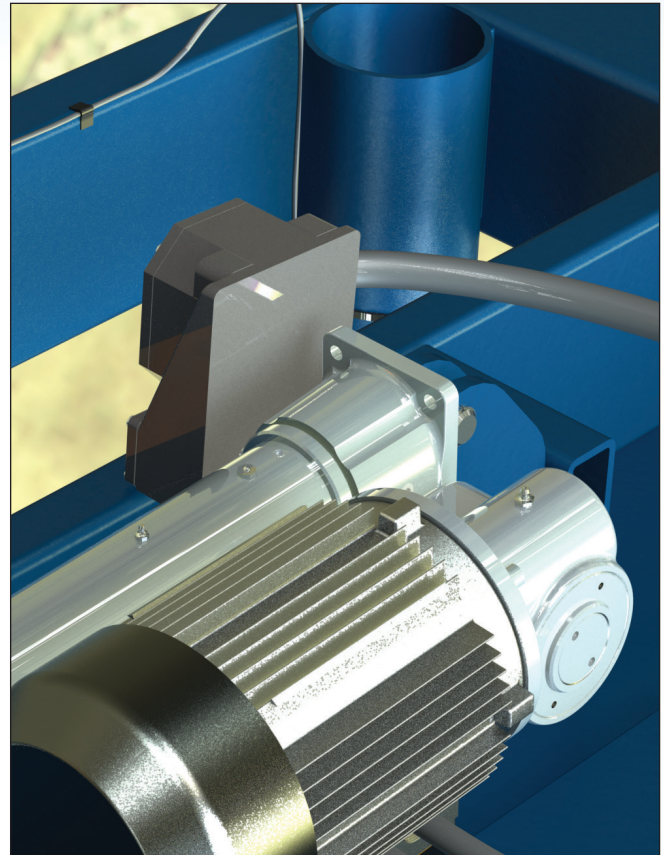

Nook/Thomson Electric Cylinders used in as the brake mechanism in an overhead crane.

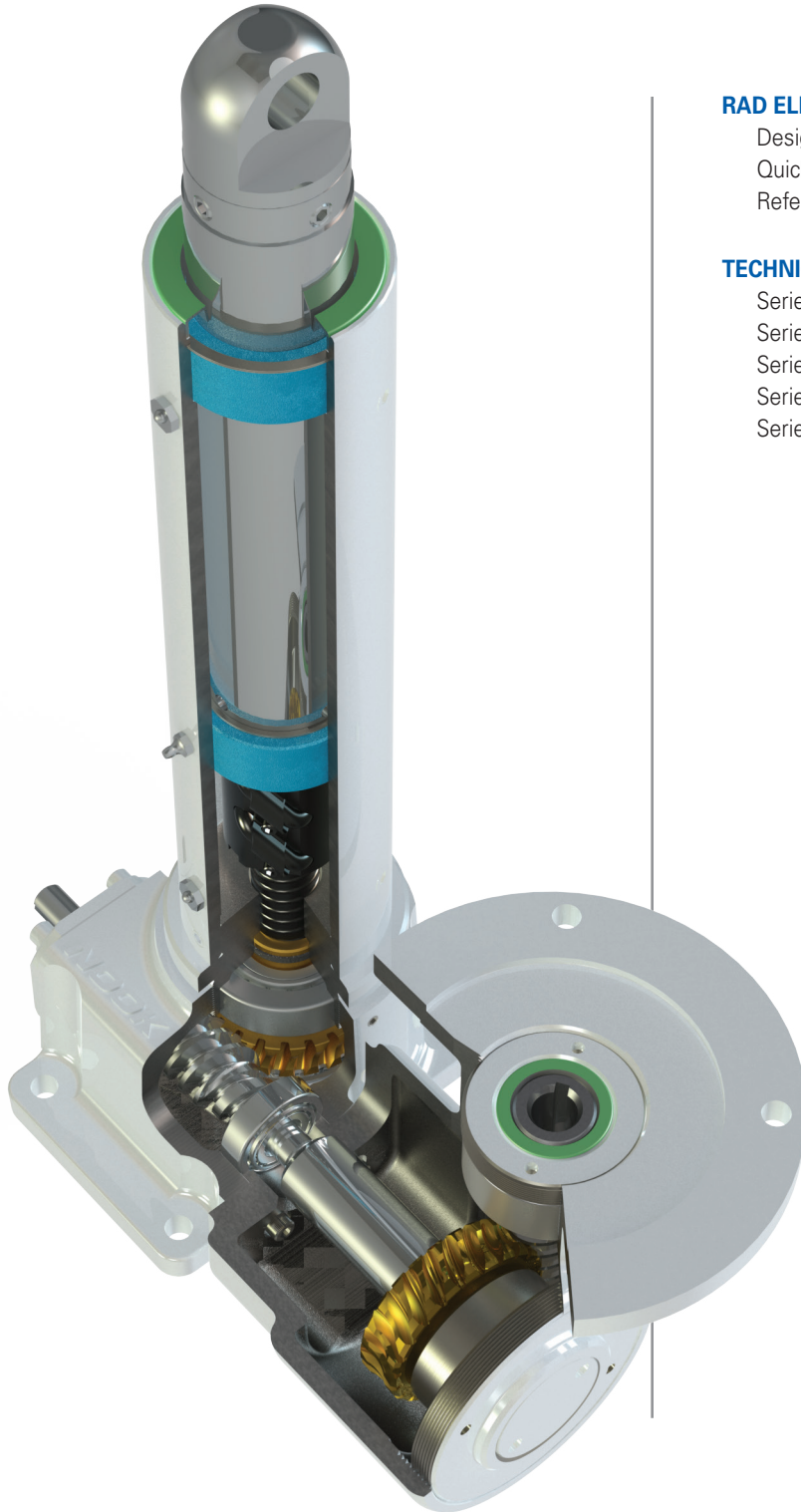

RAD ELECTRIC CYLINDERS54-57

Design Data 54-55

Quick Reference 56

Reference Number System 57

TECHNICAL DATA58-67

Series RAD-25 58-59

Series RAD-30 60-61

Series RAD-50 62-63

Series RAD-100..... 64-65

Series RAD-200 66-67

RAD DESIGN DATA

BALL SCREW MODELS

	MODEL NUMBER	PRIMARY GEAR RATIO	SECONDARY GEAR RATIO	SCREW SIZE	TURNS OF WORM PER INCH OF TRAVEL	TORQUE TO RAISE 1 LB (IN-LB)*	MAX LOAD (LB)	MAX INPUT (HP)**
25 SERIES	RAD - 2566 - HL	6:1	6:1	1000-1000 SRT RA	36	0.0102	5,000	1
	RAD - 2562 - HL	6:1	12:1	1000-1000 SRT RA	72	0.0037	5,000	1
	RAD - 2566 - ML	6:1	6:1	1000-0500 SRT RA	72	0.0057	5,000	.5
	RAD - 2566 - HD	6:1	6:1	1000-0250 SRT RA	144	0.0026	5,000	.5
	RAD - 2562 - HD	6:1	12:1	1000-0250 SRT RA	288	0.0015	5,000	.33
	RAD - 2522 - HD	12:1	12:1	1000-0250 SRT RA	576	0.0009	5,000	.33
	RAD - 2546 - HD	24:1	6:1	1000-0250 SRT RA	576	0.0010	5,000	.33
30 SERIES	RAD - 3066 - HD	6:1	6:1	1171-0413 SRT RA	87.18	0.0041	6,000	.5
	RAD - 3062 - HD	6:1	12:1	1171-0413 SRT RA	174.36	0.0026	6,000	.33
	RAD - 3022 - HD	12:1	12:1	1171-0413 SRT RA	348.2	0.0026	6,000	.25
	RAD - 3046 - HD	24:1	6:1	1171-0413 SRT RA	348.96	0.0018	6,000	.25
50 SERIES	RAD - 5066 - HL	6:1	6:1	1500-1000 SRT RA	36	0.0098	10,000	1
	RAD - 5046 - HL	24:1	6:1	1500-1000 SRT RA	144	0.0039	10,000	1
	RAD - 5066 - HD	6:1	6:1	1500-0473 SRT RA	76	0.0046	10,000	1
	RAD - 5062 - HD	6:1	12:1	1500-0473 SRT RA	152	0.0028	10,000	1
	RAD - 5046 - HD	24:1	6:1	1500-0473 SRT RA	304	0.0019	10,000	1
100 SERIES	RAD - 10086 - HL	8:1	6:1	1500-1000 SRT RA	48	0.0081	20,000	1
	RAD - 10046 - HL	24:1	6:1	1500-1000 SRT RA	144	0.0041	20,000	1
	RAD - 10086 - HD	8:1	6:1	1500-0473 SRT RA	101.28	0.0038	20,000	1
	RAD - 10082 - HD	8:1	12:1	1500-0473 SRT RA	202.58	0.0023	20,000	1
	RAD - 10046 - HD	24:1	6:1	1500-0473 SRT RA	303.96	0.0020	20,000	1
200 SERIES	RAD - 20088 - HL	8:1	8:1	2250-1000 SRT RA	64	0.0062	40,000	5
	RAD - 20048 - HL	24:1	8:1	2250-1000 SRT RA	192	0.0031	40,000	3
	RAD - 20088 - HD	8:1	8:1	2250-0500 SRT RA	128	0.0031	40,000	3
	RAD - 20048 - HD	24:1	8:1	2250-0500 SRT RA	384	0.0016	40,000	2

* At motor input

** Based on 35% Duty Cycle. Refer to page 10 for horsepower rating definitions.

RAD DESIGN DATA
ACME SCREW MODELS

	MODEL NUMBER	PRIMARY GEAR RATIO	SECONDARY GEAR RATIO	SCREW SIZE	TURNS OF WORM PER INCH OF TRAVEL	TORQUE TO RAISE 1 LB (IN-LB)*	MAX LOAD (LB)	MAX INPUT (HP)**
25 SERIES	RAD - 2566 - A4	6:1	6:1	1"-4 RA	144	0.0064	5,000	1
	RAD - 2562 - A4	6:1	12:1	1"-4 RA	288	0.0039	5,000	.75
	RAD - 2522 - A4	12:1	12:1	1"-4 RA	576	0.0023	5,000	.5
	RAD - 2546 - A4	24:1	6:1	1"-4 RA	576	0.0027	5,000	.33
30 SERIES	RAD - 3066 - A4	6:1	6:1	1¼"-4 RA	144	0.0071	6,000	1
	RAD - 3062 - A4	6:1	12:1	1¼"-4 RA	288	0.0043	6,000	.75
	RAD - 3022 - A4	12:1	12:1	1¼"-4 RA	576	0.0025	6,000	.5
	RAD - 3046 - A4	24:1	6:1	1¼"-4 RA	576	0.0030	6,000	.5
50 SERIES	RAD - 5066 - A3	6:1	6:1	1½"-2½ RA	96	0.0096	10,000	1
	RAD - 5062 - A3	6:1	12:1	1½"-2½ RA	192	0.0058	10,000	1
	RAD - 5046 - A3	24:1	6:1	1½"-2½ RA	384	0.0037	10,000	1
100 SERIES	RAD - 10086 - A2	8:1	6:1	2"-2 RA	96	0.0096	20,000	1
	RAD - 10082 - A2	12:1	12:1	2"-2 RA	192	0.0058	20,000	1
	RAD - 10046 - A2	24:1	6:1	2"-2 RA	288	0.0049	20,000	1
200 SERIES	RAD - 20088 - A2	8:1	8:1	2½"-2 RA	128	0.0086	40,000	7.5
	RAD - 20048 - A2	24:1	8:1	2½"-2 RA	384	0.0043	40,000	3
	RAD - 20088 - A3	8:1	8:1	2½"-3 RA	192	0.0078	40,000	7.5
	RAD - 20048 - A3	24:1	8:1	2½"-3 RA	576	0.0039	40,000	3

* At motor input

** Based on 35% Duty Cycle. Refer to page 10 for horsepower rating definitions.

QUICK REFERENCE

RAD MODEL STANDARD WITH MOTORS

BALL SCREW CYLINDERS

MODEL NUMBER	DYNAMIC CAPACITY (LBF)	TRAVEL RATE (IN./MIN)
RAD-2566-HL / 10XX	3,550	48
RAD-5066-HL / 10XX	4,000	48
RAD-10086-HL / 10XX	4,275	36
RAD-3066-HD / 05XX	4,775	20
RAD-2546-HD / 02XX	5,000	3
RAD-2562-HD / 03XX	5,000	6
RAD-5066-HD / 10XX	5,000	23
RAD-2566-ML / 05XX	5,000	24
RAD-2562-HL / 10XX	5,000	24
RAD-3062-HD / 03XX	5,250	10
RAD-3022-HD / 02XX	6,000	5
RAD-5046-HL / 10XX	8,000	12
RAD-5046-HD / 10XX	9,000	6
RAD-5062-HD / 10XX	9,000	11
RAD-10046-HL / 10XX	9,750	12
RAD-10086-HD / 10XX	10,000	17
RAD-10082-HD / 10XX	15,000	9
RAD-10046-HD / 10XX	18,750	6
RAD-20088-HL / 50XX	30,000	27
RAD-20048-HL / 30XX	35,000	9
RAD-20088-HD / 30XX	35,000	13.5
RAD-20048-HD / 20XX	40,000	4.5

ACME SCREW CYLINDERS

MODEL NUMBER	DYNAMIC CAPACITY (LBF)	TRAVEL RATE (IN./MIN)
RAD-5066-A3 / 10XX	2,700	18
RAD-10086-A2 / 10XX	3,800	18
RAD-5062-A3 / 10XX	4,500	9
RAD-3062-A4 / 07XX	4,925	6
RAD-2546-A4 / 05XX	5,000	3
RAD-2562-A4 / 05XX	5,000	6
RAD-2566-A4 / 07XX	5,000	12
RAD-3022-A4 / 05XX	6,000	3
RAD-3066-A4 / 10XX	6,000	12
RAD-10082-A2 / 10XX	6,275	9
RAD-5046-A3 / 10XX	7,200	4.5
RAD-10046-A2 / 10XX	7,800	6
RAD-20048-A2 / 30XX	12,500	4.5
RAD-20088-A3 / 50XX	22,250	9
RAD-20088-A2 / 75XX	31,000	13.5

XX = motor specification, see page 70

REFERENCE NUMBER SYSTEM

RAD-2512-HL / 10RT-1 / 2CA-4C / CC / 24.5 / ERS

SERIES RAD MODEL

Refer to pages 54 to 55 for available models.

SHAFT ORDER CODE

10RT - 1

CCW Position 1, 3, 5, 7
CW Position 2, 4, 6, 8

ORDER CODES (Must Include a Position)

NOTE: Both Shaft Extensions Must Be Specified.

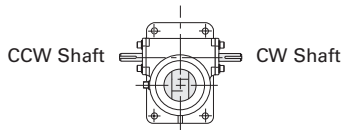

NO ACCESSORY

- SSE_ = Standard Shaft Extension, Position 1 or 2
- 000_ = Delete Shaft Extension, Position 1 or 2
- SPC_ = Special Modified Shaft Extension, Position 1 or 2

Motor Mounts Without Motor

Position 1 through 8
See page 71 for standard motor mount order codes.

Motor Mounts With Motors

Position 1 through 8
See page 71 - 72 for available motors.

Rotary Limit Switch

Position 1 C or E through 8 C or E
See page 74 - 75 for available rotary limit switches.

NOTE: A Limit Switch must specify a close or extended mounting.

Compact Limit Switch

Position 1 through 8
See page 76 - 77 for available compact limit switches.

HOUSING CONFIGURATION

- F = Standard Flange Base
- C = Clevis Base

SCREW CONFIGURATION

- T = Threaded End
- C = Clevis End
- D = Threaded rod end with female clevis installed
- P = Top Plate

TRAVEL

Travel in inches.

MODIFIER LIST

- E, B, and/or R
- E = In-Line Encoder (See p. 73)
- B = Bellows Boots (See p. 85)
- R = Rod Type Limit Switch (See p. 78)
- Optional S or M Required
- S = Standard, no additional description required
- M = Modified, additional description required

NOTE: NOT ALL OPTIONS AVAILABLE FOR ALL SIZES

SERIES RAD-25

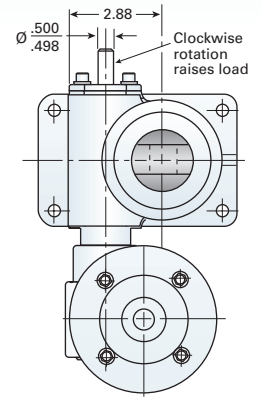

	MODEL NUMBER	Travel Rate (in/min)	Dynamic Capacity (lbf)	Screw Rated Life (in × 106)	Std. Motor HP Rating (ref.)	Std. Brake Torque (ft-lb)
Ball Screw	RAD-2566-HL / 10XX	48	3,550	.22	1	6
	RAD-2562-HL / 10XX	24	5,000	.08	1	6
	RAD-2566-ML / 05XX	24	3,400	.33	.5	3
	RAD-2562-HD / 03XX	6	5,000	.27	.33	3
	RAD-2546-HD / 03XX	3	5,000	.27	.25	3
Acme Screw	RAD-2566-A4 / 07XX	12	5,000	—	.75	6
	RAD-2562-A4 / 05XX	6	5,000	—	.5	3
	RAD-2546-A4 / 03XX	3	5,000	—	.33	3

For "XX" see page 70 for motor options. Standard motor referenced is a 1750 rpm AC brakemotor.

LIFE EXPECTANCY

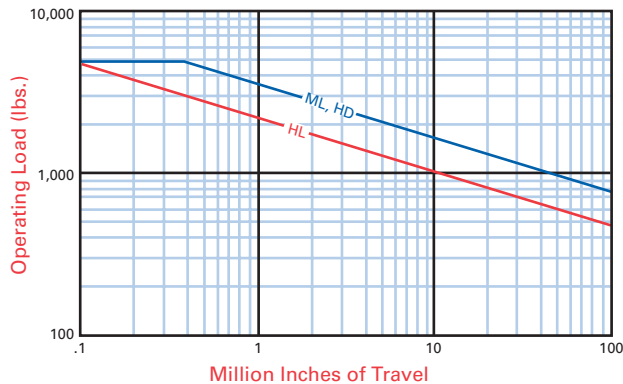

COLUMN LOAD

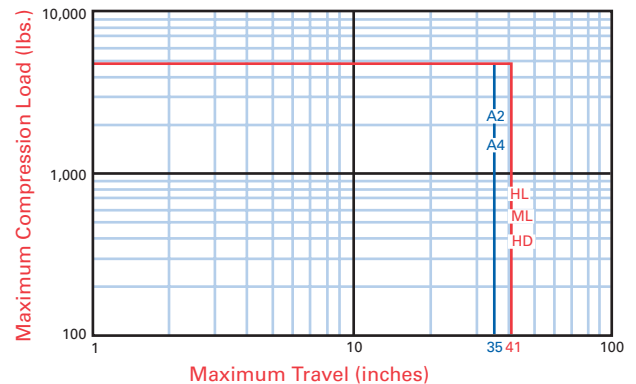

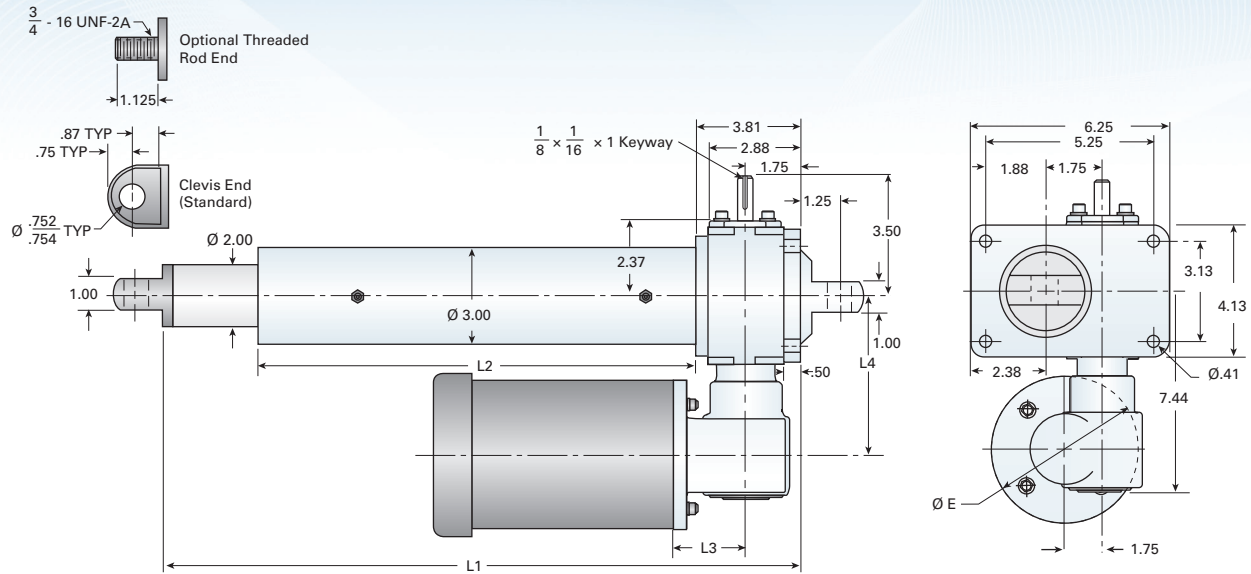

Approx Stopping Distance (in)		Max Rod Reaction Torque (in lb)	Basic Weight (lb)*	Basic Length (L1) (in)**	Basic Length (L2) (in)**
No Load	Full Load				
.08	.08	628	46	12.44	7.13
.04	.04	885	46	12.44	7.13
.014	.014	443	46	12.44	7.13
.007	.007	221	46	12.44	7.13
.003	.003	221	46	12.44	7.13
.02	—	525	44	10.38	4.75
.005	—	525	44	10.38	4.75
.004	—	525	44	10.38	4.75

NEMA FRAME SIZE	L3 (in)	L4 (in)	ØE (in)
56C	3.69	5.63	6.69

- * Ball Screw Models: Total Weight = (1.49 lb) × Travel + Basic Weight
- * Acme Screw Models: Total Weight = (1.49 lb) × Travel + Basic Weight,
- ** Total Length = Basic length + (Travel × 1.25)

Base clevis is shown in standard orientation but may be rotated 90° or per customer specification. May also be ordered with optional flange base. Motor is shown in Position 1; eight different positions are available (see page 69).

For motor dimensions, please visit www.nookindustries.com.

WARNING: Units are not to be used as personnel support or movement. Ball Screw Models are self-lowering.

SERIES RAD-30

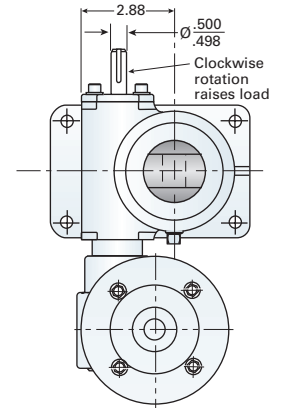

	MODEL NUMBER	Travel Rate (in/min)	Dynamic Capacity (lbf)	Screw Rated Life (in × 106)	Std. Motor HP Rating (ref.)	Std. Brake Torque (ft-lb)
Ball Screw	RAD-3066-HD / 05XX	20	4,775	.54	.5	3
	RAD-3062-HD / 03XX	10	5,250	.40	.33	3
	RAD-3022-HD / 03XX	5	6,000	.27	.33	3
Acme Screw	RAD-3066-A4 / 10XX	12	6,000	—	1	6
	RAD-3062-A4 / 07XX	6	4,925	—	.75	3
	RAD-3022-A4 / 05XX	3	6,000	—	.5	3

For "XX", see page 70 for motor options. Standard motor referenced is a 1750 rpm AC brakemotor.

LIFE EXPECTANCY

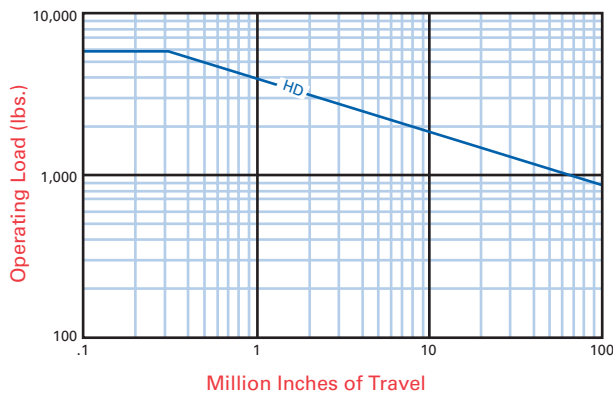

COLUMN LOAD

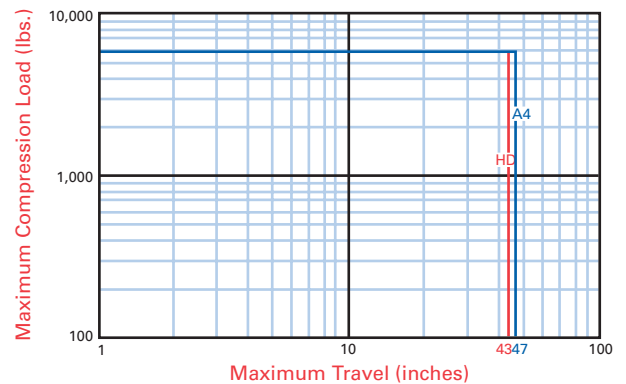

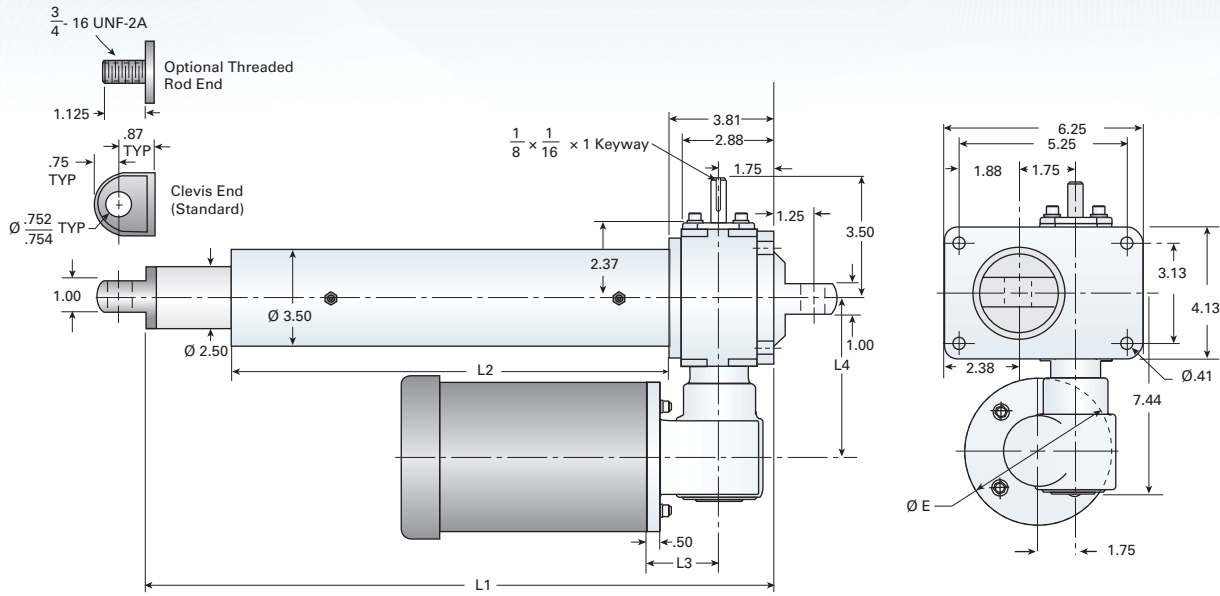

ELECTRIC CYLINDERS

Approx Stopping Distance (in)		Max Rod Reaction Torque (in lb)	Basic Weight (lb)*	Basic Length (L1) (in)**	Basic Length (L2) (in)**
No Load	Full Load				
.02	.02	349	51	12.44	7.31
.012	.012	383	51	12.44	7.31
.006	.006	439	51	12.44	7.31
.02	—	702	47	10.50	5.13
.005	—	575	47	10.50	5.13
.004	—	702	47	10.50	5.13

NEMA FRAME SIZE	L3 (in)	L4 (in)	ØE (in)
56C	3.69	5.63	6.69

* Ball Screw Models: Total Weight = (1.91 lb) × Travel + Basic Weight
 * Acme Screw Models: Total Weight = (1.95 lb) × Travel + Basic Weight

** Total Length = Basic length + (Travel × 1.25)

Base clevis is shown in standard orientation but may be rotated 90° or per customer specification. May also be ordered with optional flange base. Motor is shown in Position 1; eight different positions are available (see page 69).

For motor dimensions, please visit www.nookindustries.com.

WARNING: Units are not to be used as personnel support or movement. Ball Screw Models are self-lowering.

SERIES RAD-50

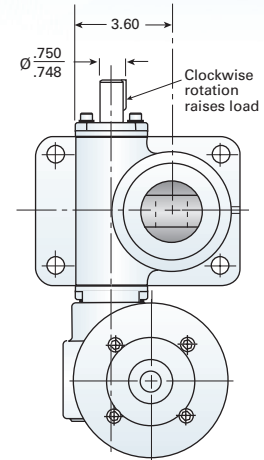

	MODEL NUMBER	Travel Rate (in/min)	Dynamic Capacity (lbf)	Screw Rated Life (in × 10 ⁶)	Std. Motor HP Rating (ref.)	Std. Brake Torque (ft-lb)
Ball Screw	RAD-5066-HL / 10XX	48	3,500	22	1	6
	RAD-5066-HD / 10XX	23	7,500	5.6	1	6
	RAD-5046-HL / 10XX	12	8,000	1.5	1	6
	RAD-5062-HD / 10XX	11	10,000	1.4	1	6
	RAD-5046-HD / 10XX	6	10,000	1.4	1	6
Acme Screw	RAD-5066-A3 / 10XX	18	4,500	—	1	6
	RAD-5062-A3 / 10XX	9	5,000	—	1	6
	RAD-5046-A3 / 10XX	4.5	10,000	—	1	6

For "XX", see page 70 for motor options. Standard motor referenced is a 1750 rpm AC brakemotor.

LIFE EXPECTANCY

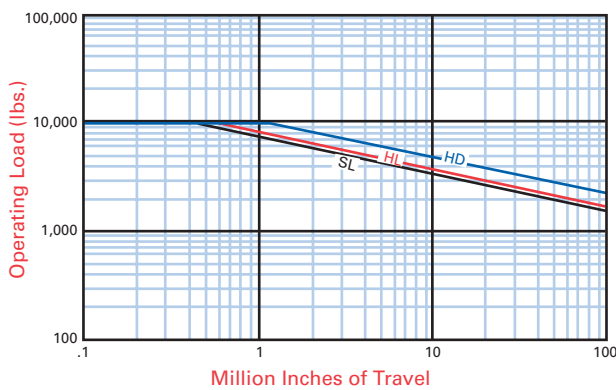

COLUMN LOAD

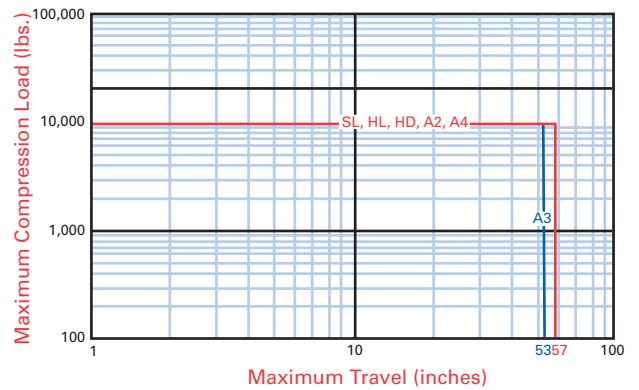

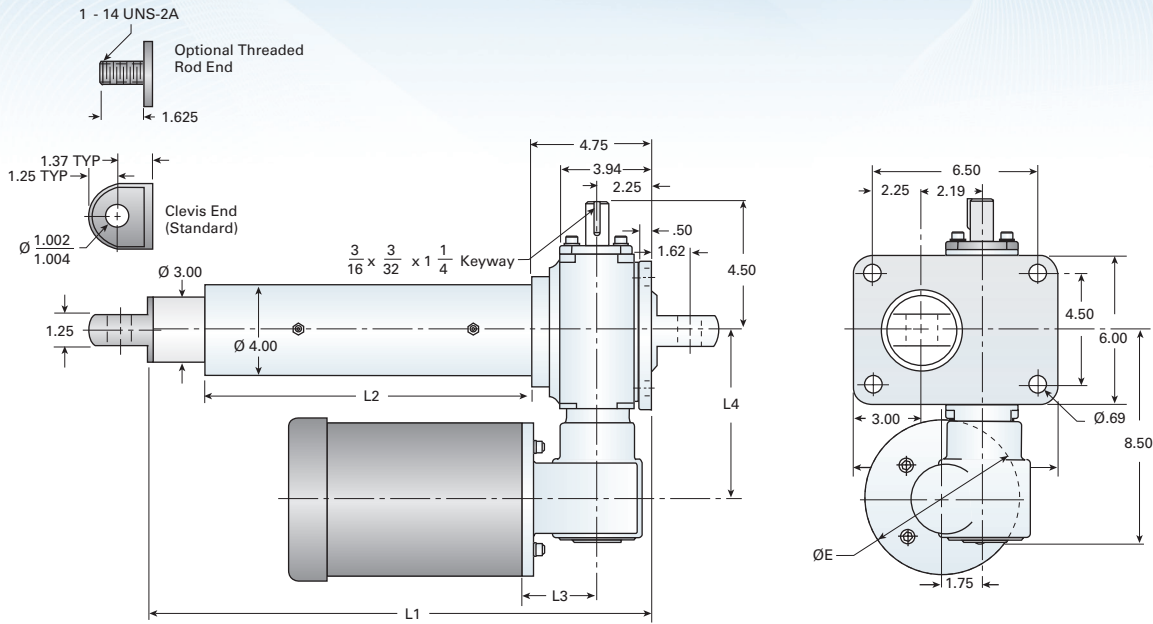

Approx Stopping Distance (in)		Max Rod Reaction Torque (in lb)	Basic Weight (lb)*	Basic Length (L1) (in)**	Basic Length (L2) (in)**
No Load	Full Load				
.08	.08	478	77	15.13	8.88
.04	.04	475	77	15.13	8.88
.02	.02	1,179	77	15.13	8.88
.02	.02	754	77	15.13	8.88
.02	.01	754	77	15.13	8.88
.03	—	402	66	12.98	6.06
.02	—	670	66	12.98	6.06
.01	—	1,073	66	12.98	6.06

NEMA FRAME SIZE	L3 (in)	L4 (in)	ØE (in)
56C	3.69	6.50	6.69

* Ball Screw Models: Total Weight = (2.28 lb) × Travel + Basic Weight

* Acme Screw Models: Total Weight = (2.28 lb) × Travel + Basic Weight

** Total Length = Basic length + (Travel × 1.25)

Base clevis is shown in standard orientation but may be rotated 90° or per customer specification. May also be ordered with optional flange base. Motor is shown in Position 1; eight different positions are available (see page 69).

For motor dimensions, please visit www.nookindustries.com.

WARNING: Units are not to be used as personnel support or movement. Ball Screw Models are self-lowering.

SERIES RAD-100

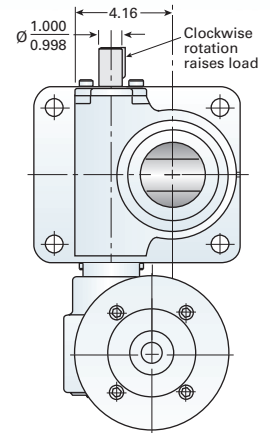

	MODEL NUMBER	Travel Rate (in/min)	Dynamic Capacity (lbf)	Screw Rated Life (in × 106)	Std. Motor HP Rating (ref.)	Std. Brake Torque (ft-lb)
Ball Screw	RAD-10086-HL / 10XX	36	4,275	5.5	1	6
	RAD-10086-HD / 10XX	17	9,000	1.0	1	6
	RAD-10046-HL / 10XX	12	9,750	.47	1	6
	RAD-10082-HD / 10XX	9	15,000	.3	1	6
	RAD-10046-HD / 10XX	6	17,000	.15	1	6
Acme Screw	RAD-10086-A2 / 10XX	18	3,800	—	1	6
	RAD-10082-A2 / 10XX	9	6,275	—	1	6
	RAD-10046-A2 / 10XX	6	7,000	—	1	6

For "XX", see page 70 for motor options. Standard motor referenced is a 1750 rpm AC brakemotor.

LIFE EXPECTANCY

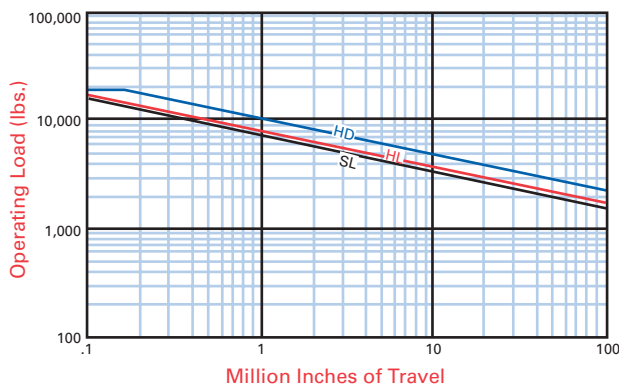

COLUMN LOAD

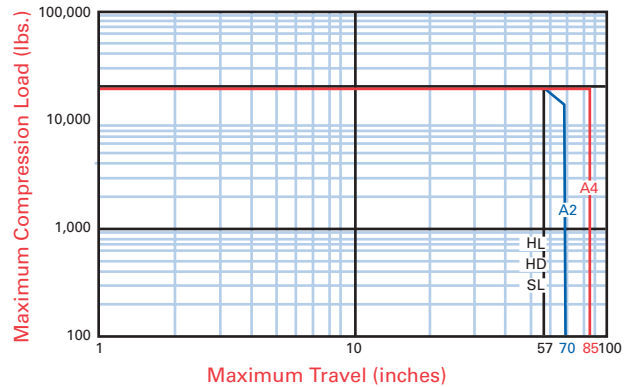

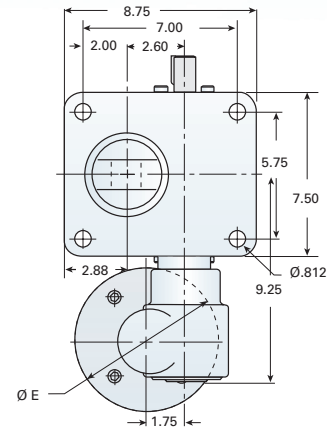
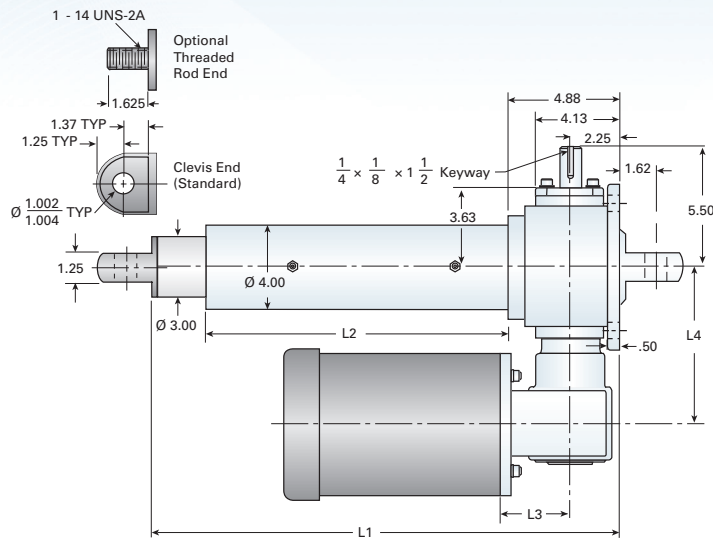

ELECTRIC CYLINDERS

Approx Stopping Distance (in)		Max Rod Reaction Torque (in lb)	Basic Weight (lb)*	Basic Length (L1) (in)**	Basic Length (L2) (in)**
No Load	Full Load				
.06	.06	758	93	15.25	8.88
.03	.03	837	93	15.25	8.88
.02	.02	1,226	93	15.25	8.88
.01	.01	1,258	93	15.25	8.88
.01	.01	1,571	93	15.25	8.88
.06	—	756	89	12.88	6.50
.07	—	1,249	89	12.88	6.50
.03	—	1,552	89	12.88	6.50

NEMA FRAME SIZE	L3 (in)	L4 (in)	ØE (in)
56C	3.69	7.25	6.69

* Ball Screw Models: Total Weight = (2.28 lb) × Travel + Basic Weight
 * Acme Screw Models: Total Weight = (2.68 lb) × Travel + Basic Weight

**Total Length = Basic length + (Travel × 1.25)

Base clevis is shown in standard orientation but may be rotated 90° or per customer specification. May also be ordered with optional flange base. Motor is shown in Position 1; eight different positions are available (see page 69).

For motor dimensions, please visit www.nookindustries.com.

WARNING: Units are not to be used as personnel support or movement. Ball Screw Models are self-lowering.

SERIES RAD-200

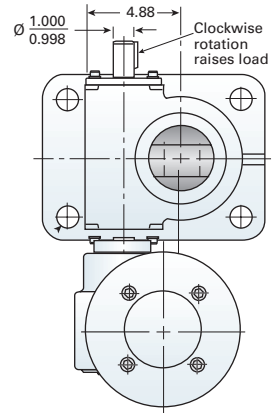

	MODEL NUMBER	Travel Rate (in/min)	Dynamic Capacity (lbf)	Screw Rated Life (in x 10 ⁶)	Std. Motor HP Rating (ref.)	Std. Brake Torque (ft-lb)
Ball Screw	RAD-20088-HL / 50XX	27	30,000	.69	5	15
	RAD-20088-HD / 30XX	13.5	35,000	.23	3	15
	RAD-20048-HL / 30XX	9	35,000	.44	3	15
	RAD-20048-HD / 20XX	4.5	40,000	.15	2	10
Acme Screw	RAD-20088-A2 / 75XX	13.5	31,000	—	7.5	25
	RAD-20088-A3 / 50XX	9	22,500	—	5	15
	RAD-20048-A2 / 30XX	4.5	12,500	—	3	15

For "XX", see page 70 for motor options. Standard motor referenced is a 1750 rpm AC brakemotor.

LIFE EXPECTANCY

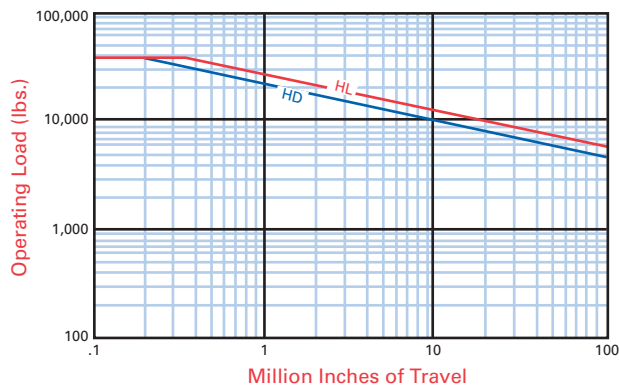

COLUMN LOAD

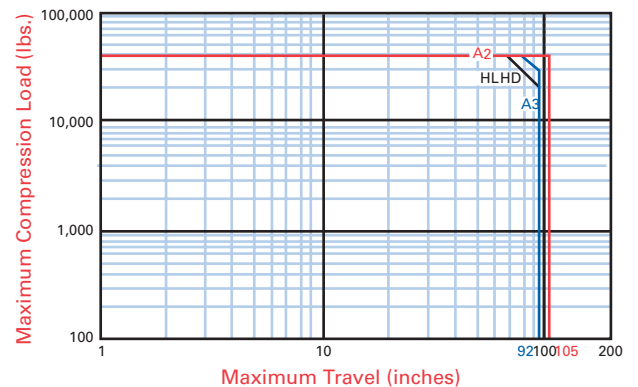

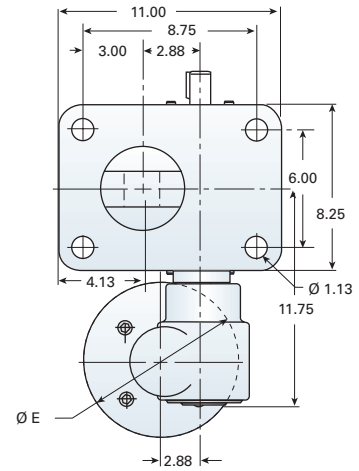
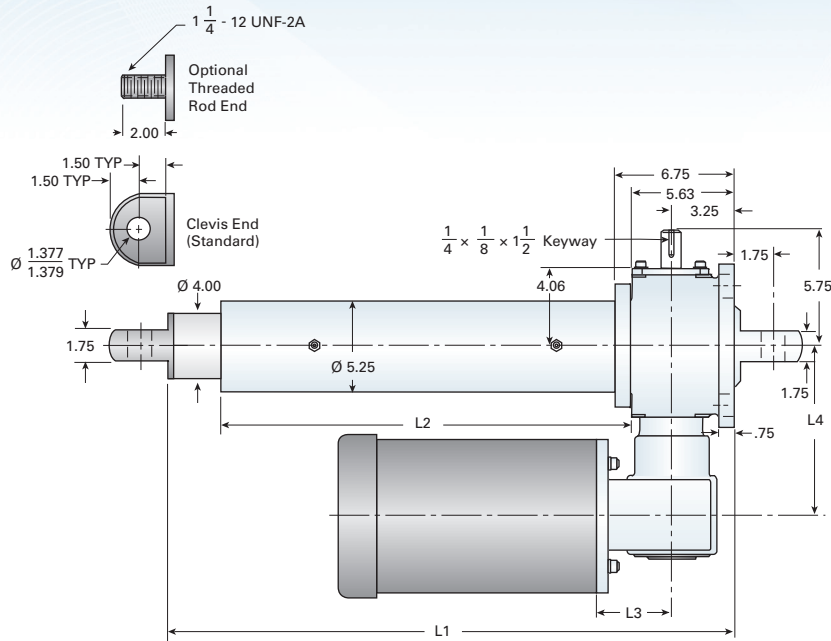

Approx Stopping Distance (in)		Max Rod Reaction Torque (in lb)	Basic Weight (lb)*	Basic Length (L1) (in)**	Basic Length (L2) (in)**
No Load	Full Load				
.09	.09	5,300	202	21.13	12.63
.03	.03	3,098	202	21.13	12.63
.02	.02	6,195	202	21.13	12.63
.01	.01	3,540	202	21.13	12.63
.03	—	7,254	187	17.44	8.94
.03	—	4,770	187	17.44	8.94
.01	—	2,925	187	17.44	8.94

NEMA FRAME SIZE	L3 (in)	L4 (in)	ØE (in)
180TC	6.12	9.00	9.12

* Ball Screw Models: Total Weight = (3.36 lb) × Travel + Basic Weight

* Acme Screw Models: Total Weight = (3.65 lb) × Travel + Basic Weight

**Total Length = Basic length + (Travel × 1.25)

Base clevis is shown in standard orientation but may be rotated 90° or per customer specification. May also be ordered with optional flange base. Motor is shown in Position 1; eight different positions are available (see page 69).

For motor dimensions, please visit www.nookindustries.com.

WARNING: Units are not to be used as personnel support or movement. Ball Screw Models are self-lowering.

ACCESSORIES

Nook/Thomson offers many accessories to accommodate specific applications. From motor mounts to limit switches to lubricant, Nook has the electric cylinder accessories to realize the linear motion needs of any application.



DD MOTOR MOUNTS
 page 68



RAD MOTOR MOUNTS
 page 69



MOTORS
 page 70

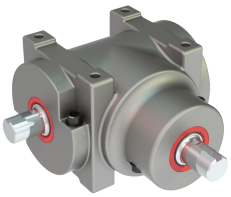

MITER GEAR ASSEMBLIES
 page 75



LINKJAC™ SHAFTING
 page 78-79

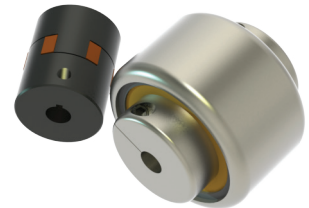

FLEXIBLE COUPLINGS
 page 80-81

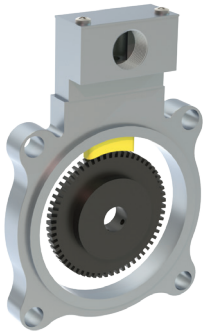

IN-LINE ENCODERS
page 71



LIMIT SWITCHES
page 72-74



ROD-TYPE LIMIT SWITCH
page 74

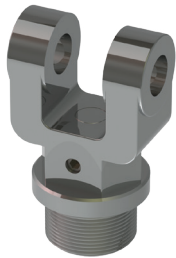

MOUNTING CLEVISES
page 82



BELLOWS BOOTS
page 83

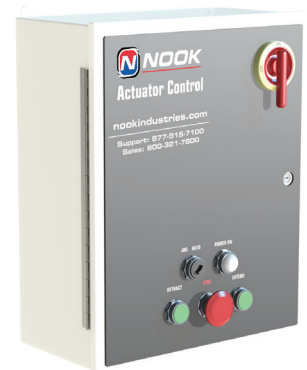

CONTROL PANELS
page 84-85

DD MOTORS AND MOTOR MOUNTS

Nook/Thomson DD motor mount assemblies are designed for standard motors and include jaw type couplings.

These assemblies are stocked for DD-25, DD-50, DD-100 and DD-200 and are available for the cylinder sizes listed in the table. Non-standard motor mounts can be designed for special requirements including, special couplings, small NEMA frame motors, DIN standard motors, stepper motor and servomotor designs. Contact Nook/Thomson for additional information.

DD Series electric cylinders can be ordered with industrial quality induction motors. Motors with internally and externally wired brake motors are available. Brake motors utilize an integral, spring actuated brake. Standard motors are 3-phase, 230-460 VAC, 60hz, 1,725 rpm. Single-phase motors are 115-130 VAC, 60hz, 1,725 rpm. All motors are rated for continuous duty. Specific duty motors such as wash down or explosion-proof can be supplied upon request. See charts on page 70 for order codes.

CAUTION: Ball screw cylinders are self-lowering. A brake of sufficient torque is required to hold the load with a ball screw cylinder. Be sure to verify that the brakemotor selected has sufficient brake torque for your application.

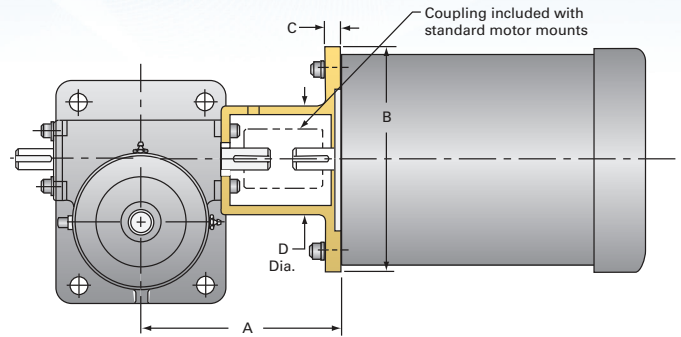

CYLINDER SERIES	NEMA FRAME SIZE	ORDER CODE W. MOTOR ADAPTER	DIMENSIONS			
			A	B	C	D
DD-5	42	X02	4.48	4.63	.50	2.69
	48	X04	4.48	4.63	.50	3.12
DD-10	56C	X05	5.71	6.63	.49	3.12
DD-25	56C	X05	6.25	6.63	.63	3.50
	140TC	X14	6.25	6.63	.63	3.50
DD-50	56C	X05	7.25	6.75	.56	3.75
	140TC	X14	7.25	6.75	.56	3.75
	180TC	X18	8.00	9.25	.75	3.75
DD-100	56C	X05	8.25	6.75	.50	4.38
	140TC	X14	8.25	6.75	.50	4.38
	180TC	X18	9.00	9.25	.75	4.38
DD-200	56C	X05	8.66	6.75	.50	3.75
	140TC	X14	8.66	6.75	.50	3.75
	180TC	X18	9.00	9.25	.63	5.25
	213TC	X21	9.68	8.88	.88	5.69

HOW TO ORDER A MOTOR MOUNT (WITH OR WITHOUT A BRAKEMOTOR)

EXAMPLE:

DD-1008-HD / X05-1 / 000-1 / CC / 24.0 / S



Mounting Position

Order Code for Motor Adapter (see above)

See page 68 for Order Code with Motor

DD MOTOR MOUNT POSITIONS

①

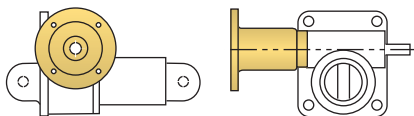

②

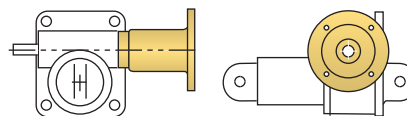

RAD MOTOR MOUNTS

The RAD Motor Mount is a compact, high quality worm gear reducer enclosed in a ductile iron housing. It mounts directly to the input side of the electric cylinder. Motors mount quill-style to a standard NEMA C-face. These assemblies are stocked for RAD-25, RAD-50, RAD-100 and RAD-200. Non-standard motor mounts can be designed for special requirements including, special couplings, small NEMA frame motors, DIN standard motors, stepper motor and servomotor designs. Contact Nook Industries for additional information.

The RAD Motor Mount is a secondary worm gear reducer that reduces speed and increases torque to the input of the electric cylinder. If motor clearance is an issue, an RAD cylinder may be selected to optimize motor orientation.

RAD Series Electric Cylinders can be ordered with industrial quality induction motors. Motors with internally and externally wired brake motors are available. Brake motors utilize an integral, spring actuated brake. Standard motors are 3-phase, 230-460 VAC, 60hz, 1,725 rpm. Single-phase motors are 115-130 VAC, 60hz, 1,725 rpm. All motors are rated for continuous duty.

CAUTION: Ball screw cylinders are self-lowering. A brake of sufficient torque is required to hold the load with a ball screw cylinder. Be sure to verify that the brakemotor selected has sufficient brake torque for your application.



RAD MOTOR MOUNT POSITIONS

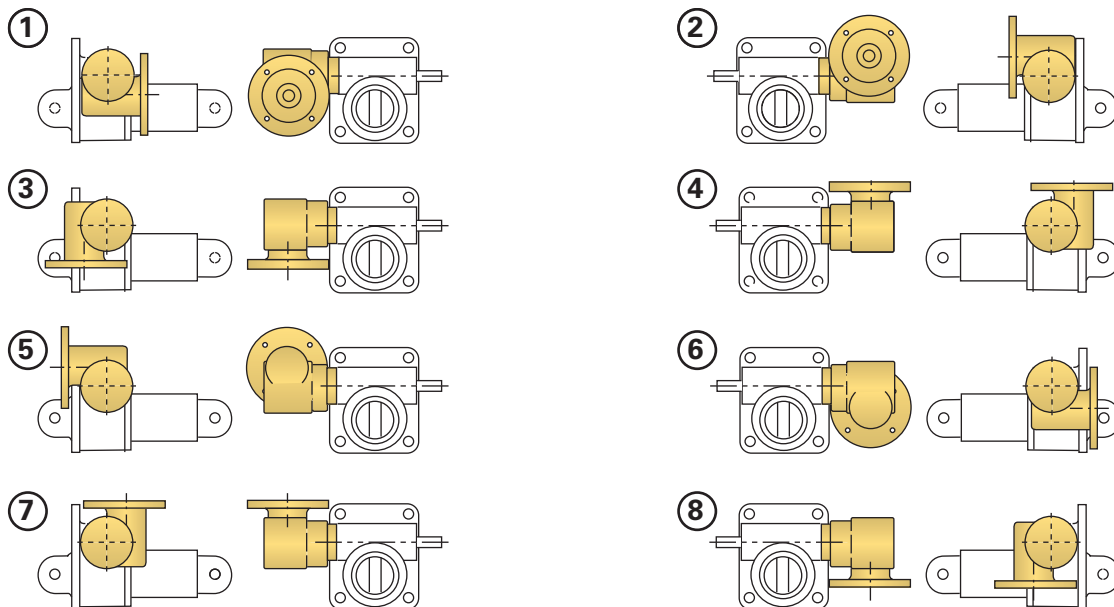

BRAKEMOTOR REFERENCE

Nook/Thomson Electric Cylinders can be supplied with industrial quality motors. Brake motors include a spring actuated, electrically released braking mechanism which will hold a load when the power is off. In normal operation, power is applied and removed to the motor windings and brake release simultaneously.

If it is desired to operate the brake separately, as when used with a speed control, the brake needs to be wired externally. Motors provided by Nook Industries can either be supplied with the brake wired externally to accommodate speed controllers, or internally for simplicity of use.

Standard motors are: 3 phase 208-230 / 460 VAC, 60 Hz. 1,725 rpm. Also available are single phase motors at: 115 / 230 VAC, 60 Hz. 1,725 rpm. All motors are rated for continuous duty.

NOTE: For inverter duty motors or additional options, contact Nook Industries.

Motor HP	EXTERNALLY WIRED BRAKE MOTOR PRODUCT CODE				INTERNALLY WIRED BRAKE MOTOR	
	STD Motor 208-230/460 3PH [Brake ft-lbs.]	Wash Down MOTOR IP55 • 208-230/460 3PH [Brake ft-lbs.]	Explosion Proof DIVISION 1 • CLASS 1,2 • GROUP F & G • 208/230/460 • 3PH [Brake ft-lbs.]	Economy Motor* 208-230/460 3PH SLIPPAGE ~ 10% [Brake ft-lbs.]	Single Phase 115/230 1PH [Brake ft-lbs.]	
1/4	–	–	–	02MT [7]	02BS [3]	
1/3	–	–	–	03MT [7]	03BS [3]	
1/2	05RT [3]	05RW [3]	05RE [3]	05MT [7]	05BS [3]	
3/4	07RT [6]	07RW [6]	07RE [6]	07MT [7]	07BS [6]	
1	10RT [6]	10RW [6]	10RE [6]	10MT [7]	10BS [3]	
1 1/2	15RT [6]	15RW [10]	–	15MT [9]	–	
2	20RT [10]	20RW [10]	20RE [10]	20MT [20]	–	
3	30RT [15]	30RW [15]	30RE [15]	30MT [20]	–	
5	50RT [25]	50RW [25]	50RE [25]	50MT [25]	–	
7 1/2	75RT [35]	–	–	75MT [40]	–	

* Motor rpm between 1620 and 1680 for Economy motors. For speed critical application please contact Nook Engineering.

SERVO/STEPPER MOTORS

Servo or Stepper Electric Cylinders offer the ability to attach a servo or stepper motor to a ball screw or machine screw jack. Using a servo or stepper motor increases control of acceleration, deceleration, travel rate and positioning accuracy compared with standard NEMA framed motors.

Custom Motor Adaptors are designed to accommodate any specified coupling and motor. Servo or Stepper Electric Cylinders can be delivered as a complete assembly, including a vendor-specified motor. Contact Nook/Thomson for further assistance with jack applications requiring servo or stepper motors.

IN-LINE ENCODER

In-Line Encoder Is Installed Between the Motor Adapter and Motor

For position sensing at the input shaft, the in-line encoder option may be factory installed between the motor and motor adapter or Right-Angle Reducer. This low-cost option requires minimal space. When used with worm gear type cylinders, it leaves the extension shaft side of the cylinder free for clearance, for a rotary limit switch, or for coupling to another cylinder .

The In-line encoder's quadrature output design allows detection of both speed and direction of shaft rotation.

The in-line encoder option mounts to a motor and therefore requires an optional motor mount or right-angle reducer.

Sensing speed range:	0 -10,000 rpm
Pulse Output:	60 pulses/revolution
Supply voltage:	+5 to 24 Volts DC +/-5%
Supply current:	60 mA typical, 115 mA maximum
Output drive capability:	250 mA per channel continuous
Maximum load:	50 ohms per channel

Encoder is face mounted between the motor and motor mount and will offset the length of the motor .61 inches for NEMA 56 and 140 frames and .88 inches for NEMA 180 and 210 frames.



HOW TO ORDER AN IN-LINE ENCODER:

Specify the Cylinder reference number, using the system described on page 35 or 55.

EXAMPLE:

DD-1008-HD / 10RT-2 / 000-1 / CC / 24.0 / ES

Product Code

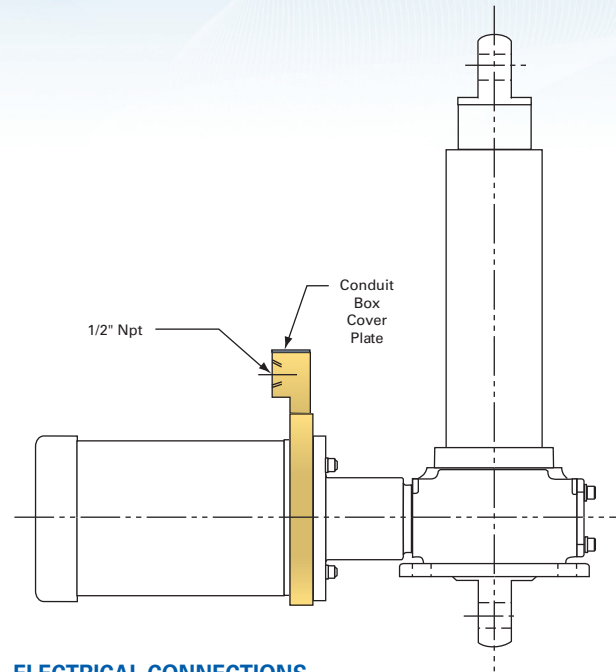

ELECTRICAL CONNECTIONS

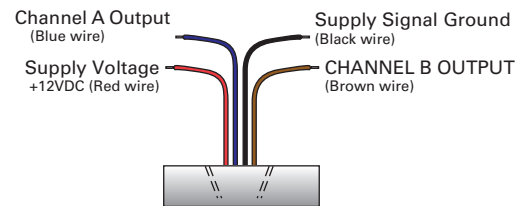

OUTPUT CHANNEL WAVEFORMS

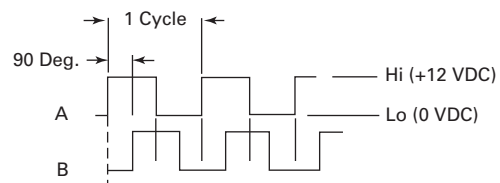

OUTPUT CHANNEL SCHEMATIC (CHANNELS A & B)

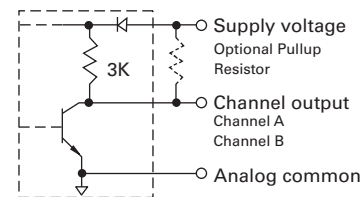

ROTARY LIMIT SWITCH

Every motorized Electric Cylinder must be controlled so that power to the motor is turned off and the brake engaged before the limits of mechanical travel are reached.

The rotary limit switch senses extension shaft rotation and provides switch contact closures that can be used to control motors.

This sturdy, durable assembly is available with two or four circuits or two circuits and a potentiometer. Each circuit has a separate rotating cam that actuates a high quality switch. The switch actuation may be individually and infinitely adjusted anywhere within the travel of the cylinder.

These assemblies contain gear reducers with ratios that vary according to the model and travel of the electric cylinders. Nook/Thomson selects ratios that result in maximum cam rotation for best accuracy, repeatability and minimum hysteresis. In most cases, with full travel of the actuator, the cam will rotate $\frac{3}{8}$ to $\frac{7}{8}$ of a revolution to actuate a switch. In the event that the cam continues to rotate, the switch returns to its original state after approximately 25° of rotation, with no damage to the limit switch assembly.

A 2-circuit switch assembly is useful for limiting the maximum and minimum extension. A 4-circuit assembly gives the possibility of additional signals for other user purposes. The potentiometer version is used to provide an analog signal for sensing cylinder position.

Single Pole Double Throw (SPDT) switches are standard and Double Pole Double Throw (DPDT) switches are optional. These assemblies are dust protected and meet NEMA 4 and 5 standards for oil and water tightness.

A rotary limit switch assembly is mounted to the extension shaft side of the Worm Gear Screw Cylinder opposite the motor.

A rotary limit switch is available for Electric Cylinder Series DD-25 and RAD-25 and larger. Most cylinder models have close and extended mounts for the switches to provide clearance around the switch housing. See the charts below for dimensions.

Switches are factory installed to assure proper assembly in the correct orientation for the specified mounting position.

CAUTION: Limit switches are not adjusted at the factory. Switches should be set after installation.

PRODUCT CODE	NUMBER OF CIRCUITS	SWITCH TYPE	POTENTIOMETER
2CA	2	SPDT	NO
2CC	2	DPDT	NO
4CA	4	SPDT	NO
4CE	4	DPDT	NO
PTA	2	SPDT	YES
PTC	2	DPDT	YES

Explosion Proof model also available. Contact Nook Engineering for more information.

HOW TO ORDER A ROTARY LIMIT SWITCH

Specify:

- Product code (see table below)
- Mounting Position (1 through 8 - see following page)
- Close or Extended Mount (C or E)

Insert the correct designation in the Electric Cylinder reference number (see page 35 or 55).

Example:

2.5-MSJ-U 6:1 / SSE-1 / **2CA-4E** / FT / 24.5 / S
 Extension ——— Position
 shaft designation

Examples of rotary limit switch designations:

- 2CA-4C – 2-circuit, SPDT, position 4, close mount
- 4CE-1E – 4-circuit, DPDT, position 1, extended mount
- C = Close mount on
- E = Extended mount (see following page)

IMPORTANT: These designation numbers are not complete part numbers. These assemblies contain gear reducers with ratios that vary according to the model and travel of the cylinder. If you are ordering a replacement switch assembly, complete information on the electric cylinder is required.



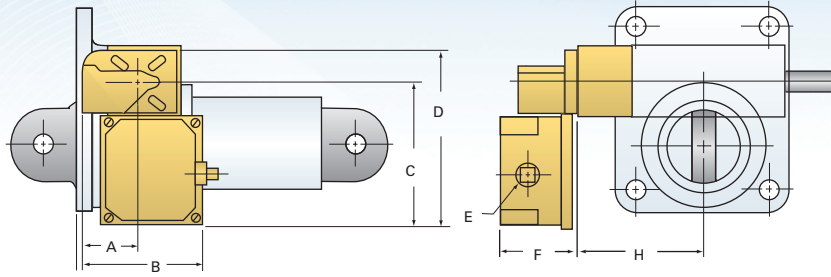

CIRCUITS	DIMENSIONS					
	A	B	C	D	E	F
2 CIRCUIT	2.46	5.25	6.24	7.62	¾-NPT	3.25
4 CIRCUIT OR 2 CIRCUIT WITH POTENTIOMETER	2.46	5.25	8.24	9.62	1-NPT	3.88

SERIES	DIMENSION H CLOSE MOUNT	DIMENSION H EXT. MOUNT
DD & RAD 25	2.75	3.56
DD & RAD 30	2.75	3.56
DD & RAD 50	3.56	4.56
DD & RAD 100	3.88	5.56
DD & RAD 200	4.41	5.81

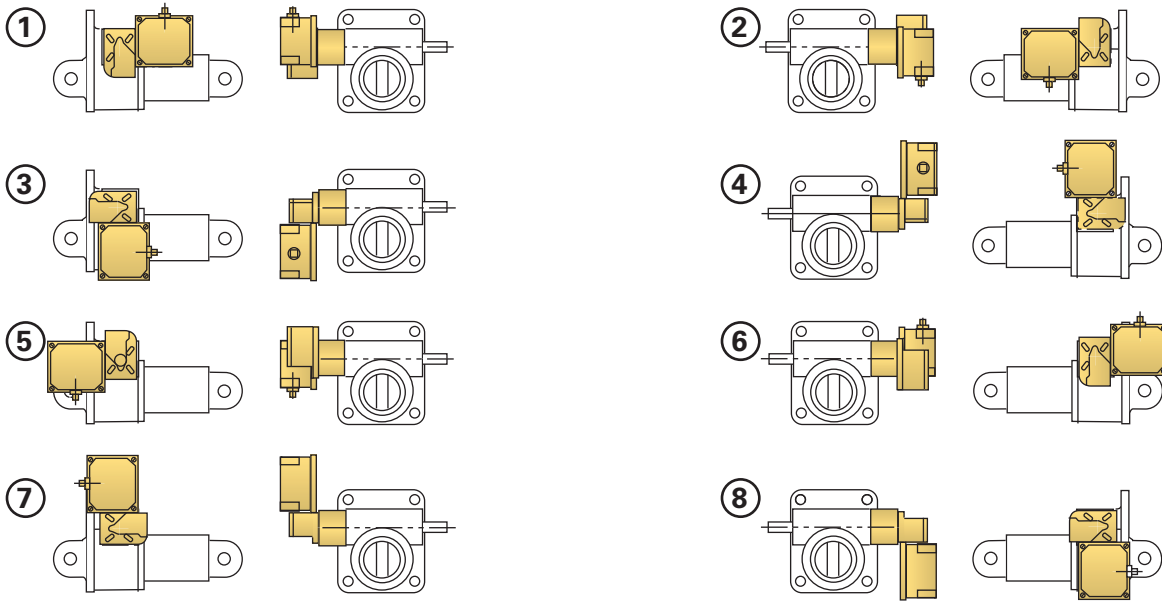

ELECTRICAL RATINGS:

Switches:

DC Current 115 Volts SPDT, .50 amps, DPDT, .80 A
 AC Current 115 Volts SPDT, 15 amps, DPDT, 10 A
 10-Turn Potentiometer 0-500 OHM, 2 Watt

NOTE: While the 10-turn potentiometer is rated for 0-500 Ohms, as implemented in the rotary limit switch assembly, it cannot and should not operate over its full range. Minimum and maximum resistance values cannot be known until the unit is installed and final travel limit adjustments have been made, therefore, the device connected to the potentiometer should include provisions for trimming to compensate for these values.

WIRING DIAGRAMS:

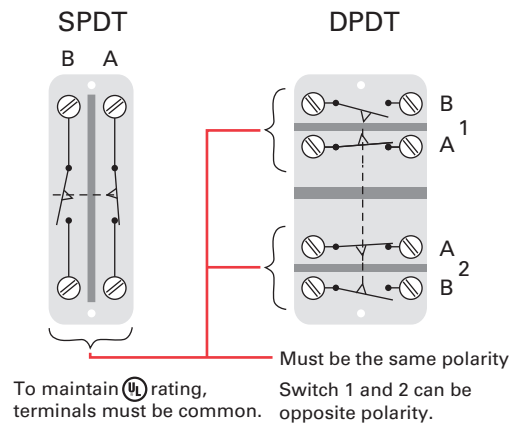

ROD-TYPE LIMIT SWITCH ASSEMBLIES

The Rod-Type Limit Switch provides two SPDT switches used to limit the maximum and minimum cylinder extension. The switch assembly mounts to the cylinder tubes for convenient access and leaves the extension shaft free for other purposes. The simple design permits easy installation and maintenance. Independent adjustment allows for quick and easy fine tuning of the travel limits.

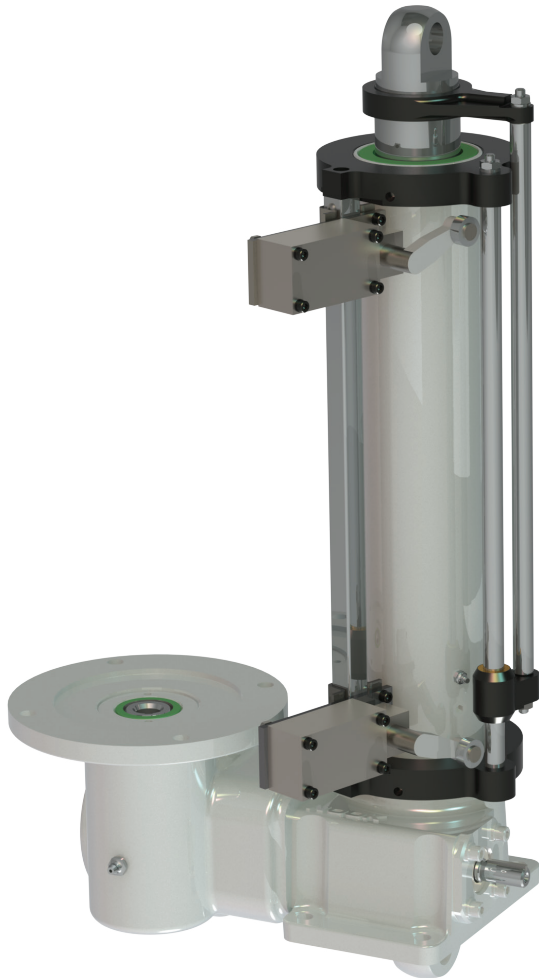

Every Electric Cylinder should be installed so that electrical power to the motor is turned off and the brake engaged before the travel limits are reached, or damage to the cylinder can result.

Minimum travel is 6" and maximum travel is 72" for all Electric Cylinders equipped with rod-type limit switches.

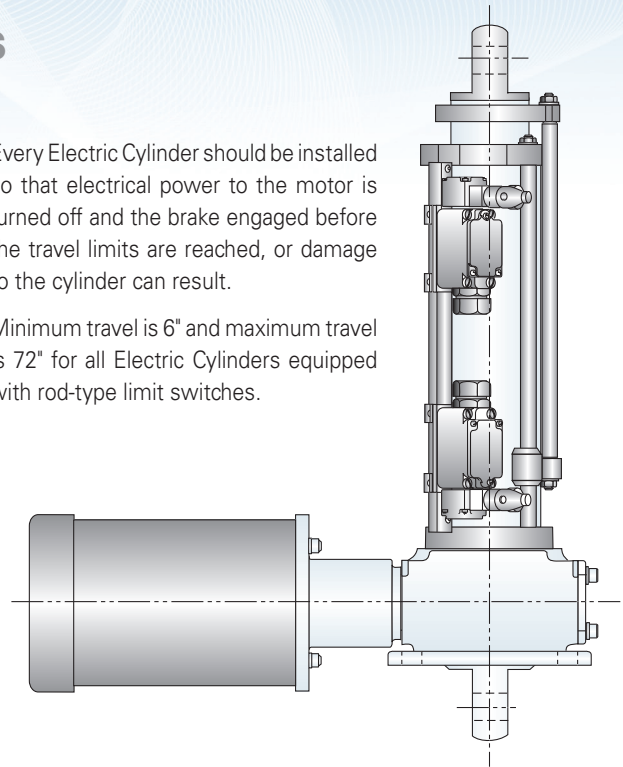

HOW TO ORDER A ROD-TYPE LIMIT SWITCH:

Specify the Electric Cylinder reference number, using the system described on page 35 or 55.

EXAMPLE: DD-1008-HD / 10BT-2 / 000-1 / CC / 24.0 / SR

"R" anywhere in this field _____ indicates Rod-Type Limit Switch Assembly

SWITCH ENCLOSURE RATINGS

NEMA	1, 2, 3, 3R, 4, 5, 6, 12, 13
IEC	IP67

SERIES	CLEARANCE RADIUS "R"
DD-5	4.00
DD-10	3.66
DD & RAD-25	4.00
DD & RAD-30	4.20
DD & RAD-50	4.66
DD & RAD-100	4.60
DD & RAD-200	5.40

ROD-TYPE LIMIT SWITCH DIMENSIONS:

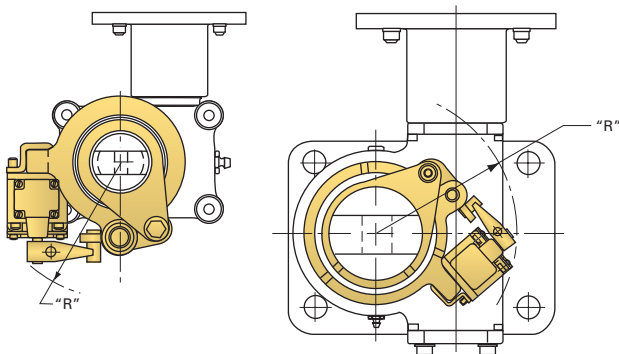

Explosion Proof model also available. Contact Nook Engineering for more information.

Use of Rod Limit Switches in outdoor application with direct exposure to harsh environmental conditions is not advisable. Contamination will prevent the switch from functioning properly.

STANDARD MITER GEAR ASSEMBLIES

GEAR RATIO 1:1 AND 2:1

Nook/Thomson Electric Cylinders may be used in multiple arrangements by connecting shafting, couplings and gear boxes to simultaneously transmit power to the input shafts of the electric cylinders. Nook/Thomson provides gearboxes for use with electric cylinders. Make certain that the total torque and horsepower required by the arrangement does not exceed the ratings of the box. Miter gear boxes can be operated up to 900 rpm. Higher speeds are permissible at lower torque ratings. Noise levels may increase at higher speeds. The operating efficiency of a miter gear box is 90%

	Gear Ratio	Rated Load at 1700 rpm				Est. Weight (lb)
		Continuous Duty		Intermittent Duty		
		HP	Torque (in-lb)	HP	Torque (in-lb)	
GB210	1:1	7.67	284	14.44	535	6¼
GB210S*	1:1	5.75	213.24	10.82	401.32	6¼
GB210S-R2*	2:1	3.01	111.54	5.56	206.31	6¼
GB15	1:1	30.5	1,131	38.33	1,421	26
GB12**	1:1	60.51	2724.13	70.48	3172.91	39

* Spiral bevel gear set

** Rated Load calculated at 1400 rpm

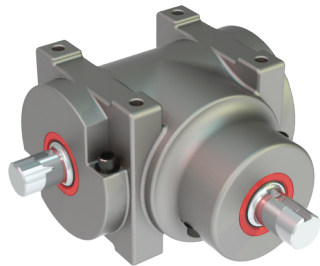

Gears are forged alloy steel. Shafts are stressproof steel ground and polished. Clockwise (CW) and counterclockwise (CCW) notations indicate direction of shaft rotation when facing outer end of shaft. All shaft arrangements will operate opposite direction for that shown. To order, specify model number and desired shaft arrangement.

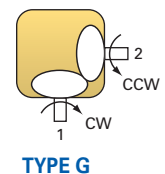
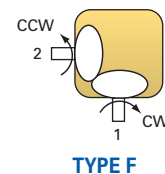
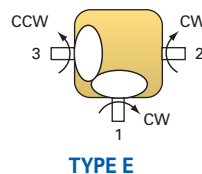
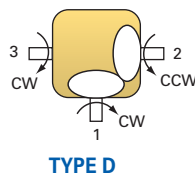
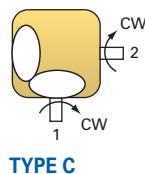
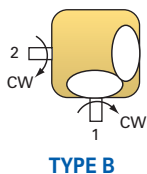

GB210, GB210S, GB210S-R2

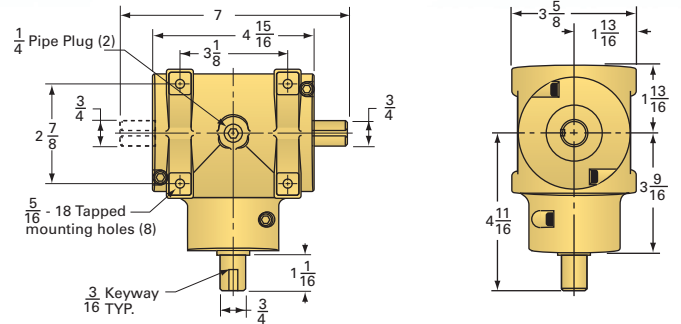

GB15

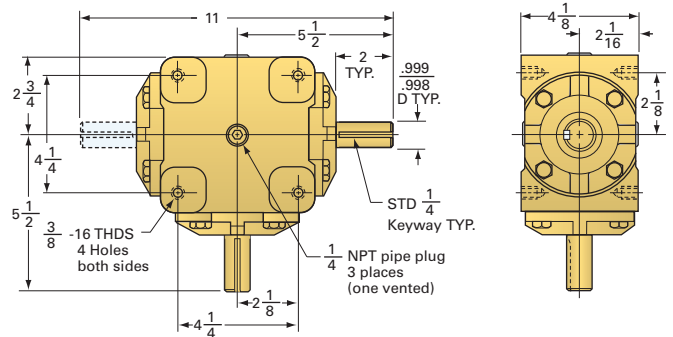

GB12

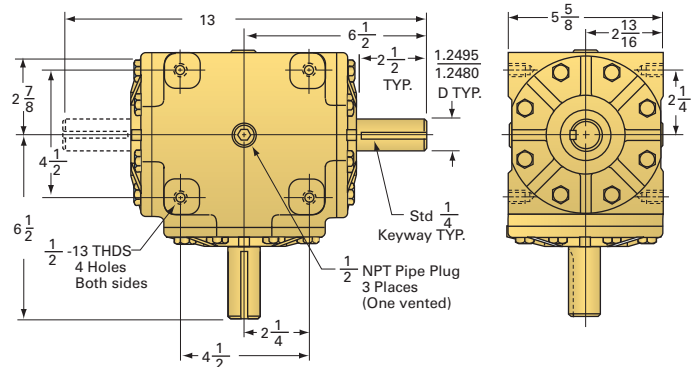

GB210, GB210S, and GB210S-R2 are filled with EP-90 Gear lubricant at time of shipment. GB15 and GB12 are shipped dry. Fill with EP-90 Gear Lubricant: Capacity 1 qt.

ENVIRONMENTAL CYLINDERS OPTIONS

Electric Cylinders are ruggedly designed for most industrial applications. The standard cylinder is capable of withstanding ambient temperatures ranging from 0°F to 180°F. The actuator tubes are precision-ground hard chrome-plated with the outer tube and housing enamel painted.

Nook/Thomson offers several options for demanding applications. Application such as; Indoor-wet/harsh, indoor wet/food grade, outdoor, marine, and high-temp (180°F to 300°F).

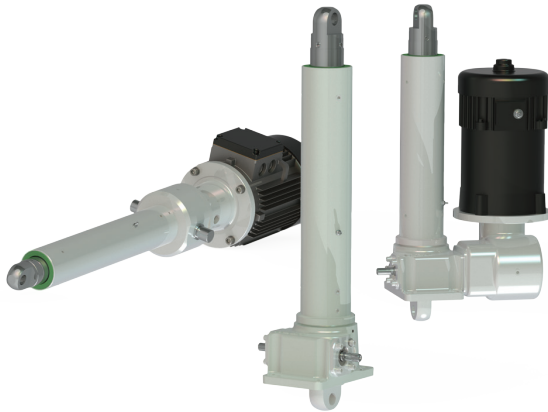

INDOOR - WET/HARSH ENVIRONMENT

Intended for basic wash down with harsh cleaning chemicals.

Change includes:

- Stainless Steel Fasteners and Hardware
- Fluorocarbon (Viton) Seals
- Corrosion Resistant Motor Adapters and Reducers
- Corrosion Resistant Limit Switches
- Hypalon Coated Nylon Boot
- Self-Priming Epoxy Paint



INDOOR - WET/FOOD GRADE ENVIRONMENT

Intended for food processing application.

Change includes:

- Stainless Steel Fasteners and Hardware
- Fluorocarbon (Viton) Seals
- Corrosion Resistant Motor Adapters and Reducers
- Corrosion Resistant Limit Switches
- Hypalon Coated Nylon Boot
- Self-Priming Epoxy Paint
- Food Grade Grease



OUTDOOR

Intended for basic outdoor and weather environments.

Change includes:

- Stainless Steel Fasteners and Hardware
- Fluorocarbon (Viton) Seals
- Corrosion Resistant Motor Adapters and Reducers
- Corrosion Resistant Limit Switches
- Hypalon Coated Nylon Boot
- Self-Priming Epoxy Paint as Primer
- Polyurethane Outdoor Coating for Topcoat



MARINE

Intended for salt air outdoor and weather environments.

Change includes:

- Stainless Steel Fasteners and Hardware
- Fluorocarbon (Viton) Seals
- Corrosion Resistant Motor Adapters and Reducers
- Corrosion Resistant Limit Switches
- Hypalon Coated Nylon Boot
- Self-Priming Epoxy Paint as Primer
- Marine Polysiloxane Outdoor Coating for Topcoat



HIGH-TEMP (180°F TO 300°F)

Intended for indoor high ambient temperature environments.

Change includes:

- Grease Mobiltemp SHC32
- Fluorocarbon (Viton) Seals
- Silicone Coated Fiberglass Boot (max 550 deg F).
- Tempercoate H20 Primer
- Tempercote H20 (Color: Med. Gray) for Topcoat

NOTE: High-Temp Cylinders do not accommodate Motor Mounts, Limit Switches, and non- standard RAD Gearboxes.

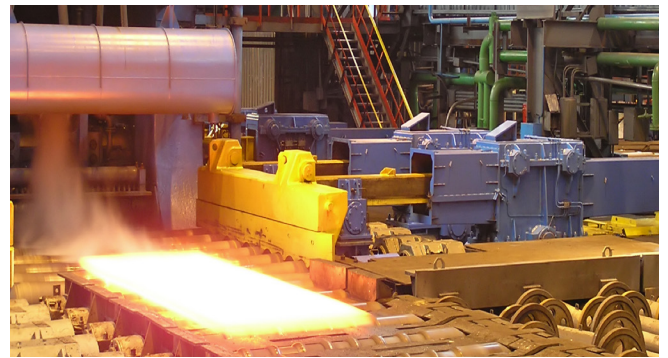

LOW-TEMP (-40°F TO 0°F)

Intended for outdoor low ambient temperature environments.

Change includes:

- Stainless Steel Fasteners and Hardware
- Grease Aeroshell #22
- Fluorocarbon (Viton) Seals
- Hypalon Coated Nylon Boot
- Self-Priming Epoxy Paint as Primer
- Polyurethane Outdoor Coating for Topcoat

NOTE: Low-Temp Cylinders do not accommodate Limit Switches and non- standard RAD Gearboxes.



LINKJAC™ SHAFTING

LinkJac™ Line Shafting is used to interconnect the input shafts of Nook/Thomson Electric Cylinders used in a multiple arrangement. The shafts transfer the torque from the motor to the electric cylinder or from cylinder to cylinder. LinkJac™ is available in either steel Line Shafting available in standard lengths up to 144", or in aluminum Tubular Shafting with bonded journals of stainless steel available in lengths up to 196". Custom end machining and other diameters are available. Contact Nook/Thomson for information.

SELECTION:

There are two major concerns when selecting an interconnect shaft:

Critical Speed: How fast will the shaft be turning?

Torsional Twist: How much torque will the shafts be transmitting?

The two characteristics of a LinkJac™ Line Shaft or Tubular Shafting which can be varied to accommodate these requirements are:

Length of the shaft

Diameter of the shaft

When selecting a LinkJac™ Line Shaft or Tubular Shafting, use the largest diameter or shortest length which satisfies both Critical Speed and Torsional Twist equations.

Critical Speed: The speed that excites the natural frequency of the screw is referred to as the critical speed.

Since the speed can also be affected by shaft straightness and assembly alignment, it is recommended that the maximum speed be limited to 80% of the calculated critical speed value. The theoretical formula to calculate critical speed in rpm is;

$$N_{\text{Speed}} = .6192 \times \left(\frac{\pi}{L}\right)^2 \times C_s$$

WHERE:

N = Critical Speed in revolutions per minute

L = Length of unsupported shaft in inches

Cs = Value list from table below

LINE SHAFTING

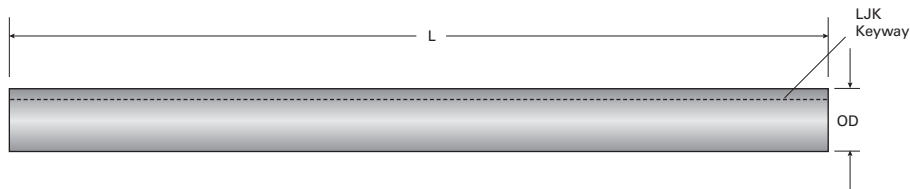

	OD (in)	KEYWAY (in)	KEYWAY LENGTH (in)	A	B	MATERIAL	C _T	C _S	WEIGHT/IN (lb)
LJ-8	1/2	-	-	-	-	Steel	1,235	3.895 × 10 ⁵	0.056
LJ-12	3/4	-	-	-	-	Steel	6,250	5.851 × 10 ⁵	0.125
LJ-16	1	-	-	-	-	Steel	19,500	1.168 × 10 ⁶	0.223
LJ-24	1 1/2	-	-	-	-	Steel	95,000	1.169 × 10 ⁶	0.502
LJK-8	1/2	1/8 × 1/16	Full Length	-	-	Steel	1,235	3.895 × 10 ⁵	0.056
LJK-12	3/4	3/16 × 3/32	Full Length	-	-	Steel	6,250	5.851 × 10 ⁵	0.125
LJK-16	1	1/4 × 1/8	Full Length	-	-	Steel	19,500	1.168 × 10 ⁶	0.223
LJK-24	1 1/2	3/8 × 3/16	Full Length	-	-	Steel	95,000	1.169 × 10 ⁶	0.502

* When adding modified keyways to standard LinkJac™ shafting, please contact Nook/Thomson Engineering.

Torsional Twist: The degree of twist experienced by LinkJac™ Line Shaft or Tubular Shafting when a given amount of torque is applied. To insure proper synchronization of cylinder motion, it is recommended not to exceed 1° of twist. The theoretical formula to calculate torsional twist in degrees is;

$$NT_{\text{twist}} = T \times \frac{L}{C_t}$$

WHERE:

N = Torsional Twist in degrees

L = Length of unsupported shaft in inches

C_t = Value list from table below

T = Torque

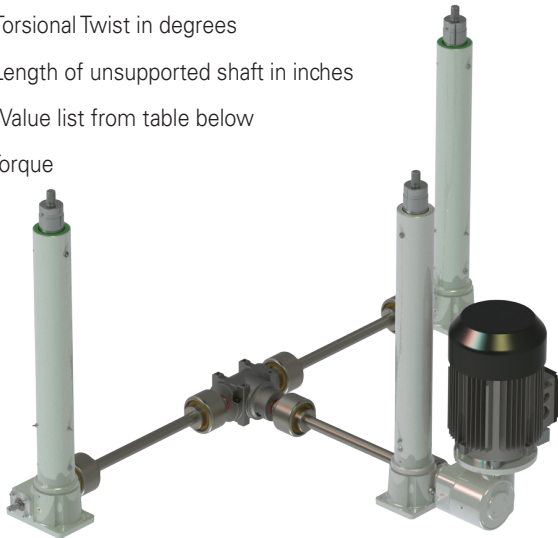

Design Information:

The length used in the previously listed formulas is the unsupported length of the shaft. If support bearings are used on the shaft, the length is the longest unsupported length between bearings.

The previously listed formulas give a theoretical value of critical speed and torsional twist. Alignment, straightness and stiffness of the system all contribute to determining the actual value.

The torque in the system is also limited by the torque capacity of the coupling.

Allow appropriate spacing between the electric cylinder input shaft and the LinkJac™ Line Shaft or Tubular Shafting inside the coupling.

For some combinations of couplings and electric cylinders, the radius of the suggested coupling is larger than the distance from the center of the worm shaft to the base.

Nook/Thomson offers a range of couplings for use with LinkJac™ Line Shaft or Tubular Shafting and Electric Cylinder products in both floating shaft and supported shaft applications. See pages 80-81 for more information.

METRIC TUBULAR SHAFTING

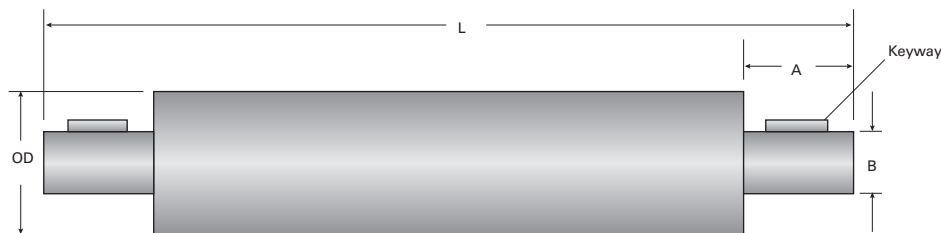

	OD (in [mm])	KEYWAY (mm)	KEYWAY LENGTH (mm)	A (mm)	B (mm)	MATERIAL	C _T	C _S	WEIGHT/IN (lb)
LJT-27	1.06 [27]	5 × 2.5	28	35	14 _{h7}	Aluminium	3,375	9.798 × 10 ⁵	0.035
LJT-40	1.57 [40]	6 × 3	40	45	18 _{h7}	Aluminium	12,250	1.504 × 10 ⁶	0.055
LJT-50	1.99 [50]	6 × 3	40	45	22 _{h7}	Aluminium	25,000	1.907 × 10 ⁶	0.069
LJT-60	2.36 [60]	8 × 3.5	50	55	30 _{h7}	Aluminium	43,750	2.312 × 10 ⁶	0.084

FLEXIBLE COUPLINGS

Electric cylinders used alone or in multiple arrangements require couplings to transmit power to the input shaft. Nook Industries provides jaw type and flex type couplings for use with cylinders. The selection process for couplings includes the following steps:

- 1) Refer to the electric cylinder specification tables to determine torque requirements per cylinder for your application.
- 2) Determine total coupling capacity required by multiplying the torque required per cylinder by the number of cylinders to be driven by the coupling.
- 3) Check the torque required against maximum torque rating as shown in the table. Select a coupling with a maximum torque greater than the application torque.
- 4) If using flex type couplings, full-flex couplings should be used for close coupled arrangements. For floating shaft applications, use two

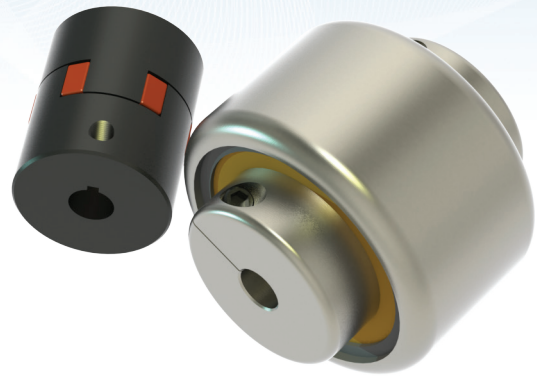

Flex-Rigid couplings. The rigid half should be mounted on the floating shaft.

All electric cylinders, shafts, couplings and motor should be carefully aligned for maximum performance. Couplings with bores other than those specified are available upon request.

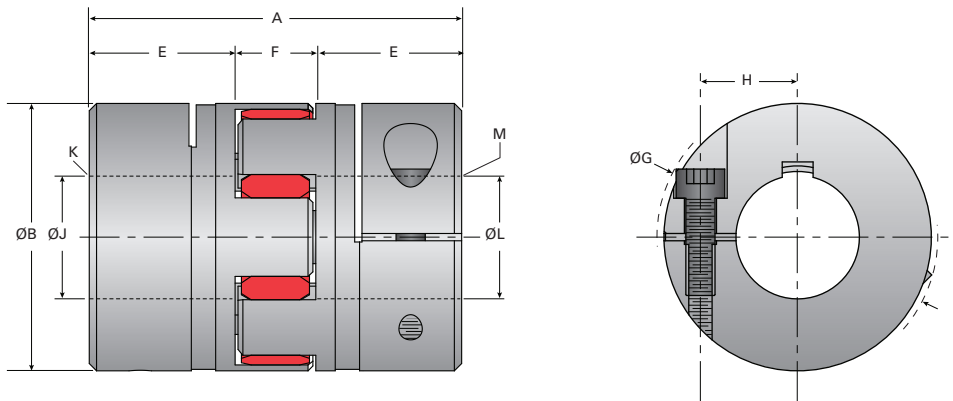

JAWTYPE SERIES

PRODUCT CODE	Max. Torque Rating (in-lb)	Approx. Wt. (lb)	Clamp Bolt Torque (in-lb)	COUPLING DIMENSIONS (in)						BORE SIZES (in)			
				A	B	E	F	G	H	J	Keyway K	L	Keyway M
C-3020-01	111	0.10	12	1.38	1.18	0.43	0.51	1.27	0.45	0.375	—	0.375	—
C-3025-01	150	0.30	93	2.60	1.57	0.98	0.63	1.81	0.57	0.500	1/8 × 1/16	0.500	1/8 × 1/16
C-3025-05	150	0.30	93	2.60	1.57	0.98	0.63	1.81	0.57	0.500	1/8 × 1/16	0.625	1/8 × 1/16
C-3025-02	150	0.30	93	2.60	1.57	0.98	0.63	1.81	0.57	0.500	1/8 × 1/16	0.750	3/16 × 3/32
C-3025-03	150	0.30	93	2.60	1.57	0.98	0.63	1.81	0.57	0.625	1/8 × 1/16	0.625	1/8 × 1/16
C-3025-04	150	0.30	93	2.60	1.57	0.98	0.63	1.81	0.57	0.625	1/8 × 1/16	0.750	3/16 × 3/32
C-3025-06	150	0.30	93	2.60	1.57	0.98	0.63	1.81	0.57	0.750	3/16 × 3/32	0.750	3/16 × 3/32
C-3030-01	531	0.62	93	3.07	2.17	1.18	0.71	2.26	0.79	0.750	3/16 × 3/32	1.000	1/4 × 1/8
C-3030-02	531	0.62	93	3.07	2.17	1.18	0.71	2.26	0.79	1.000	1/4 × 1/8	1.000	1/4 × 1/8

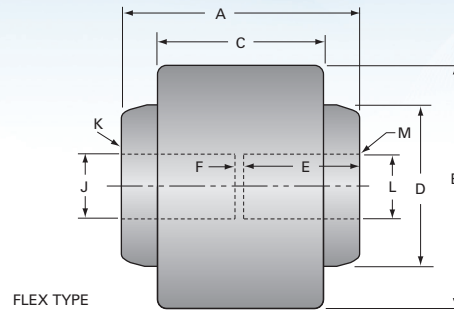

HEAVY DUTY SERIES

PRODUCT CODE		Max. Torque Rating (in-lb)	Approx. Wt. (lb)	COUPLING DIMENSIONS (in)						BORE SIZES (in)			
Full Flex	Flex-Rigid			A	B	C	D	E	F	J	Keyway K	L	Keyway M
C-1800-04	C-1805-04	2,500	5	3.125	3.125	2.00	2.00	1.50	0.125	.4995 .4990	1/8 x 1/16	.7495 .7490	3/16 x 3/32
C-1800-01	C-1805-01	2,500	5	3.125	3.125	2.00	2.00	1.50	0.125	.4995 .4990	1/8 x 1/16	.9995 .9990	1/4 x 1/8
C-1800-05	C-1805-05	2,500	5	3.125	3.125	2.00	2.00	1.50	0.125	.7495 .7490	3/16 x 3/32	.7495 .7490	3/16 x 3/32
C-1800-02	C-1805-02	2,500	5	3.125	3.125	2.00	2.00	1.50	0.125	.7495 .7490	3/16 x 3/32	.9995 .9990	1/4 x 1/8
C-1800-03	C-1805-03	2,500	5	3.125	3.125	2.00	2.00	1.50	0.125	.9995 .9990	1/4 x 1/8	.9995 .9990	1/4 x 1/8
C-1810-01	C-1815-01	7,500	8	3.75	3.75	2.53	2.375	1.82	0.125	1.2495 1.2490	1/4 x 1/8	1.2495 1.2490	1/4 x 1/8
C-1810-02	C-1815-02	7,500	8	3.75	3.75	2.53	2.375	1.82	0.125	1.3745 1.3740	5/16 x 5/32	1.2495 1.2490	1/4 x 1/8
C-1810-03	C-1815-03	7,500	8	3.75	3.75	2.53	2.375	1.82	0.125	1.4995 1.4990	3/8 x 3/16	1.2495 1.2490	1/4 x 1/8

ECONOMY SERIES

PRODUCT CODE		Max. Torque Rating (in-lb)	Approx. Wt. (lb)	COUPLING DIMENSIONS (in)						BORE SIZES (in)			
Full Flex	Flex-Rigid			A	B	C	D	E	F	J	Keyway K	L	Keyway M
P-2200-185	-	210	0.37	2.13	1.89	1.46	1.26	0.98	0.16	0.500	1/8 x 1/16	0.750	3/16 x 3/32
P-2200-193	-	210	0.37	2.13	1.89	1.46	1.26	0.98	0.16	0.625	3/16 x 3/32	0.750	3/16 x 3/32
P-2200-196	-	260	0.71	2.2	2.05	1.61	1.42	1.02	0.16	0.625	3/16 x 3/32	0.750	3/16 x 3/32
P-2200-178	-	210	0.37	2.13	1.89	1.46	1.26	0.98	0.16	0.750	3/16 x 3/32	0.750	3/16 x 3/32
P-2200-182	-	260	0.71	2.2	2.05	1.61	1.42	1.02	0.16	0.750	3/16 x 3/32	0.750	3/16 x 3/32
P-2200-183	-	610	1.64	3.31	2.6	1.81	1.73	1.57	0.16	0.750	3/16 x 3/32	1.000	1/4 x 1/8
P-2200-191	-	610	1.64	3.31	2.6	1.81	1.73	1.57	0.16	0.750	3/16 x 3/32	1.125	1/4 x 1/8
P-2200-177	-	1,170	3.31	3.46	3.62	1.97	2.56	1.46	0.55	1.000	1/4 x 1/8	1.000	1/4 x 1/8

MOUNTING CLEVISES

FEMALE ROD CLEVIS

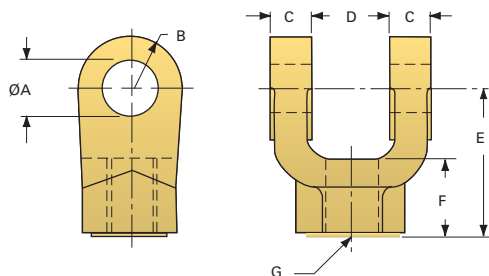

CYLINDER SERIES	Product Code	DIMENSIONS						
		ØA	B radius	C	D	E	F	G thread
5 SERIES	9012-5	.3145/.3165	$19/64$	$13/64$	$11/32$	$11/4$	$13/16$	$5/16-24$
10 SERIES	9012-8	.504/.502	$1/2$	$1/2$	$3/4$	$11/2$	$3/4$	$7/16-20$
25 SERIES	9012-12	.752/.754	$3/4$	$5/8$	$11/4$	$21/8$	$11/8$	$3/4-16$
30 SERIES	9012-12	.752/.754	$3/4$	$5/8$	$11/4$	$21/8$	$11/8$	$3/4-16$
50 SERIES	9012-16	1.002/1.004	1	$3/4$	$11/2$	$215/16$	$15/8$	1-14
100 SERIES	9012-16	1.002/1.004	1	$3/4$	$11/2$	$215/16$	$15/8$	1-14
200 SERIES	9012-22	1.377/1.379	$13/8$	1	2	$33/4$	2	$11/4-12$

NOTE: Rod Clevis with swivel bearings can be supplied. Contact Nook Engineering.

CLEVIS BRACKET

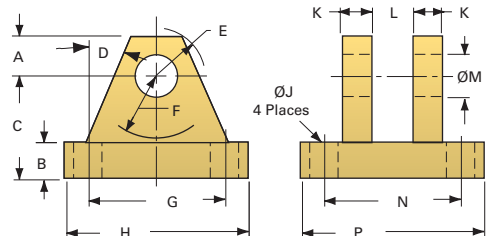

CYLINDER SERIES	PRODUCT CODE	DIMENSIONS														
		A	B	C	D	E	F	G	H	ØJ	K	L	ØM	N	P	
5 SERIES	9013-7	$3/8$	$3/8$	1	25°	$1/2$	$5/8$	1.75	$21/4$	$17/64$	$3/8$	$15/32$.4395/.4415	1.75	$21/4$	
10 SERIES	9013-8	$1/2$	$1/2$	$11/2$	25°	$5/8$	$3/4$	2.55	$31/2$	$13/32$	$1/2$	$3/4$.504/.502	2.55	$31/2$	
25 SERIES	9013-12	$3/4$	$5/8$	$17/8$	25°	$29/32$	$3/4$	3.82	5	$17/32$	$5/8$	$11/4$.752/.754	3.82	5	
30 SERIES	9013-12	$3/4$	$5/8$	$17/8$	25°	$29/32$	$3/4$	3.82	5	$17/32$	$5/8$	$11/4$.752/.754	3.82	5	
50 SERIES	9013-16	1	$3/4$	$21/4$	25°	$11/4$	$11/2$	4.95	$61/2$	$21/32$	$3/4$	$11/2$	1.002/1.004	4.95	$61/2$	
100 SERIES	9013-16	1	$3/4$	$21/4$	25°	$11/4$	$11/2$	4.95	$61/2$	$21/32$	$3/4$	$11/2$	1.002/1.004	4.95	$61/2$	
200 SERIES	9013-22	$13/8$	$7/8$	3	25°	$121/32$	2	5.73	$71/2$	$21/32$	1	2	1.377/1.379	5.73	$71/2$	

PIVOT PIN

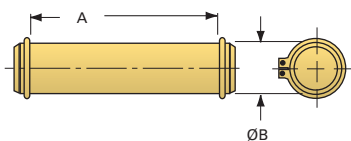

CYLINDER SERIES	PRODUCT CODE	DIMENSIONS	
		A	ØB
5 SERIES	9014-7	$115/16$.4385/.4355
10 SERIES	9014-8	$17/8$.501/.498
25 SERIES	9014-12	$25/8$.751/.748
30 SERIES	9014-12	$25/8$.751/.748
50 SERIES	9014-16	$31/8$	1.001/0.999
100 SERIES	9014-16	$31/8$	1.001/0.999
200 SERIES	9014-22	$41/8$	1.376/1.373

BELLOWS BOOTS

STANDARD AND SPECIAL BELLOWS BOOTS

Bellows boots are available for all sizes and configurations of Electric Cylinders. A boot protects the tube from contamination.

Standard boots are sewn from black neoprene-covered nylon fabric for oil, water and weather resistance and are acceptable for use in -30°F to +300°F environments. Optional materials are available for specific operating conditions (see chart).

Standard boots are furnished with tie straps for electric cylinders with greater than 65 inches travel. Tie straps are attached from convolution to convolution and help the boot extend uniformly.



Bellows Boot

SPECIAL END CONFIGURATIONS

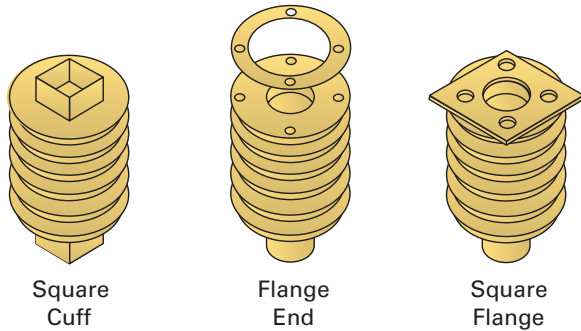

Square Cuff

Flange End

Square Flange

SPECIAL BOOT MATERIALS

DESCRIPTION TEMPERATURE	RANGE	APPLICATION COMMENTS
Hypalon-Coated Nylon	-30°F to +300°F	Chemical Resistance, Wash Down
Silicone Coated Fiberglass	-67°F to +550°F	High Temperature
Aluminum-Coated Fiberglass	-65°F to +700°F	High Temperature, Hot Chips, Welding Splatter

NOTE: Retracted boot length may increase with some special materials.



Nook Electric Cylinders used in a paper manufacturing application.

CONTROL PANELS

Nook/Thomson control panels are designed to match the motor when shipped from the factory. The control panels are acceptable to use in most industrial environments (including automotive). Functionality of the control panel can be customized to match any application and spare parts are readily available.

The control panel interconnects with other safety/control systems.



Benefits:

- The control matches the motor with no design time required
- The control is acceptable to use in most industrial environments (including automotive)
- Spare parts are readily available
- Functionality of the control can be customized to match any application
- The control interconnects with other safety/control systems

Motor Capacities:

¼ up to 15 HP 3-phase 230-460-575 VAC induction motors with or without electrically operated brakes.

- NEMA 4/12 Enclosures
- NEMA 4X also available

Internal Wiring:

- Per NFPA-79
- Main fuses with disconnect models
- UL Listed

Limit Switches:

All units have the ability to work with limit switches or custom supplied mechanical limit switches

Front Panel Indicators include Power Indicator

Front Panel Controls include maintained stop push-button, main power disconnect switch (optional), extend push-button and retract push-button. In auto mode, the load moves until limit is reached; in jog mode, the load moves while button is pressed.

CAUTION - Licensed Electrician Required at time of install.

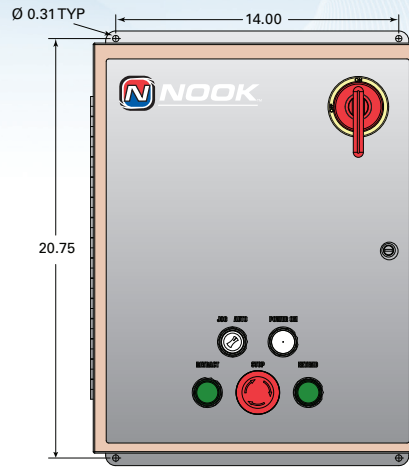
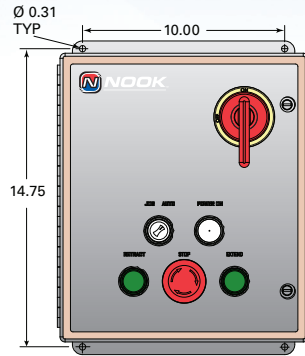

3 PH MODEL NUMBERS

HP	Voltage	Enclosure Size (in)	
		Without Disconnect	With Disconnect
1/4	230	NCB23025	NCB23025D
	460	NCB46025	NCB46025D
1/3	230	NCB23033	NCB23033D
	460	NCB46033	NCB46033D
	575	NCB57033	NCB57033D
1/2	230	NCB23050	NCB23050D
	460	NCB46050	NCB46050D
	575	NCB57050	NCB57050D
3/4	230	NCB23075	NCB23075D
	460	NCB46075	NCB46075D
	575	NCB57075	NCB57075D
1	230	NCB230100	NCB230100D
	460	NCB460100	NCB460100D
	575	NCB570100	NCB570100D
1 1/2	230	NCB230150	NCB230150D
	460	NCB460150	NCB460150D
	575	NCB570150	NCB570150D
2	230	NCB230200	NCB230200D
	460	NCB460200	NCB460200D
	575	NCB570200	NCB570200D

3 PH MODEL NUMBERS

HP	Voltage	Enclosure Size (in)	
		Without Disconnect	With Disconnect
3	230	NCB230300	NCB230300D
	460	NCB460300	NCB460300D
	575	NCB570300	NCB570300D
5	230	NCB230500	NCB230500D
	460	NCB460500	NCB460500D
	575	NCB570500	NCB570500D
7 1/2	230	NCB230750	NCB230750D
	460	NCB460750	NCB460750D
	575	NCB570750	NCB570750D
10	230	NCB231000	NCB231000D
	460	NCB461000	NCB461000D
	575	NCB571000	NCB571000D
15	230	NCB231500	NCB231500D
	460	NCB461500	NCB461500D
	575	NCB571500	NCB571500D

PRECISION LINEAR ACTUATORS



Nook/Thomson Linear Actuators are widely used in the packaging industry.



PA™ ACTUATOR

PA™ ACTUATOR..... 86-103

- Features Overview..... 88
- Definition and Terms 89
- Installation and Maintenance..... 90
- Application Example 91
- PA Actuator Overview..... 92-93
- Dimensions..... 94
- Reference Number System 95
- Sensors..... 96
- Linear Position Transducer 97
- Accessories 98
- Speed Load Curves..... 99-103

PA ACTUATOR™

FEATURES OVERVIEW

PA Actuator™ offers an expanded range of performance by providing higher loads, longer life, and increased duty cycles with higher speeds and programmability.

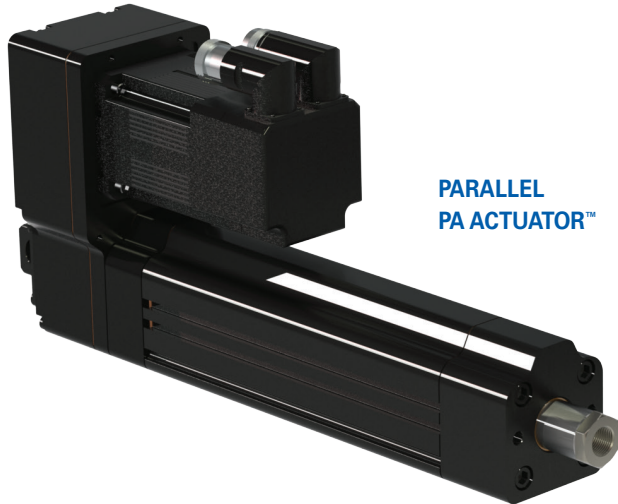

**PARALLEL
PA ACTUATOR™**



**IN-LINE
PA ACTUATOR™**

PA ACTUATOR™ ADVANTAGES

- Rated for continuous duty
- Operates at speeds up to 25 inches per second
- Long service life
- Anti-rotation device integrated
- Quiet running performance
- Complete system from one source including motor, drive, controller, and power supply
- Both ball screw and acme screw drives available
- Ball screws are used on high-speed applications
- Acme screw actuators designed for lower duty cycles where self-locking is desired.

PERFORMANCE CHARACTERISTICS

- High mechanical efficiency
- Strokes up to 24 in
- Repeatability up to ± 0.04 in
- Toothed belt drive (for parallel motor mounting)
- Standard motor and gearhead flanges for simplified selection. Optional motors are available at customer selection when specified
- IP54 Optional (motor dependent)
- IP65 Optional (motor dependent)

DEFINITIONS & TERMS

BACKLASH

Backlash (lash) is the relative axial movement between a screw and nut without rotation of the screw or nut. Backlash in PA Actuator occurs wherever reversible load conditions exist. Expected backlash is less than .010" for all either acme or ball screws. Ball Screw actuators can be factory adjusted to reduce backlash at the lift shaft by selecting bearing ball size in the ball nut. This selective fit technique can be used to achieve a minimal lash between the ball nut and ball screw of .003" to .005". Precision ball screws with preloaded nuts can be supplied when less than .003" backlash is required.

REACTION TORQUE

PA Actuators are manufactured to prevent rod reaction torque to be felt by the attaching structure. Each actuator is equipped with a low friction keyed block to prevent rotation of the rod actuator as the motor provides torque in either direction.

TRAVEL LENGTH

PA Actuator is supplied in standard travel lengths. The actuators can be built with non-standard travel lengths if required.

PA Actuator can be built with non-standard lead screws to change the actuator operating speed, or with ground or preloaded screws if required by the application.

Contact Nook/Thomson for availability of special units.

LEAD ACCURACY

Lead accuracy is the difference between the actual distances traveled versus the theoretical distance traveled based on lead. For example: Consider a lift shaft with a .5" lead and +/- .004"/foot lead accuracy. If the shaft is rotated 24 times, the distance the nut moves is 11.996 to 12.004 inches.

The rolled thread screws, as employed in products, are held within +/- .004" per foot lead error.

INPUT TORQUE

The input torque is the rotary force required at the input of the actuator to generate an output force at the actuator tube. When supplying your own motor, the torque necessary to move a given load is depends on the screw selected and the gear reduction used. Contact Nook/Thomson for specifics about torque requirements prior to selecting your unique motor.

Due to static friction, starting or "breakaway" torque can be as much as two to three times running torque. If the load is moved horizontally, the force required to move the load will be lessened in proportion to the coefficient of friction of the surface along which the load is moved. In addition, the force needed to start, stop and hold the load (inertia loading) is provided by the actuator.

SELF-LOCKING AND BRAKES

The PA Actuator is not considered a Self-Locking actuator. A brake will be required to secure the load.

NOTE: ¾-10 acme screw versions are considered self-locking.

TEMPERATURE

PA Actuator is suitable for operation within the specified limits, provided that the housing temperature is not lower than -0°F or higher than +104°F. Factory supplied grease in standard units will operate in this range. For higher or lower operating temperature ranges contact Nook/Thomson for recommendations.

END-OF-TRAVEL STOPS

The PA Actuator is supplied with travel stops, but is not intended for motor stall torque limitations. A limit switch and a brake should be used to stop the motor. Mechanical stops can cause damage to the actuator because most electric motors will deliver stall torques much higher than their rated torques and motor inertia can cause severe shock loads.

MAXIMUM LOAD

The maximum thrust load, including shock, that can be applied to the actuator without damaging the assembly.

DYNAMIC CAPACITY

The maximum allowable thrust load based on horsepower, thrust bearing, and screw limitation.

TENSION LOAD

A load that tends to "stretch" the screw.

COMPRESSION LOAD

A load that tends to "squeeze" the screw.

LOAD CAPACITY

All anticipated loads should be within the rated capacity of the actuator. Loads on the actuator in most applications include: static loads, dynamic or moving loads, cutting or other reaction forces and acceleration/deceleration loads.

For shock loads, the peak load must not exceed the rated capacity of the actuator, and an appropriate design factor should be applied commensurate with the severity of the shock.

INSTALLATION & MAINTENANCE

INSTALLATION

The alignment of the actuators directly affects their service life.

Cylinders must be properly aligned in all planes so the actuator tube can move in and out without evidence of binding. Since the majority of actuator applications use the actuators with clevis or trunnion mounts, simply align the clevises and install the actuator.

Set limit switches (or Nook/Thomson Sensors) before operating. Allow for drift when setting the position.

MAINTENANCE

PA Actuators require minimum maintenance. In addition to maintaining lubrication levels in the gearbox and tubes, the following items should be checked:

The actuator tube should be kept free of dirt. If possible, the actuator should be returned to the retracted position when not in use.

For acme actuators, lash between the lift shaft and travel nut greater than $\frac{1}{4}$ the screw pitch indicates the need for replacement of the actuator lift shaft components.

LUBRICATION

PA Actuators require lubrication to operate efficiently and with maximum life. Standard lubrication is NLGI #1.5 grease.

In normal operation, actuator lubricant should be checked once per month. Application conditions may dictate a more or less frequent lubrication cycle.

Lubricants containing additives such as molydisulfide or graphite should not be used.

The lift shafts (ball and acme screws) inside the PA Actuator tube receive lubrication through the port on the bottom side of the square extrusion. The only way to lubricate this section of the actuator is to apply some lubricant directly on the lift shaft when the actuator is fully extended beyond where the guide is past the lube port (see actuator cutaway views on page 93).

REQUIRED APPLICATION DATA

Load

- Total maximum thrust load on actuator
- Total maximum thrust load on any one actuator
- Number of actuators

Travel

- Inch Travel Rate
- Optimal speed
- Minimal acceptable speed
- Maximum acceptable speed

Duty Cycle

- Distance per cycle
- Number of cycles per time period
- Maximum distance traveled in any year
- Life desired

Configuration

- Tension, compression, or both

APPLICATION EXAMPLE

[an application example will be published in a later edition]

PA ACTUATOR™

Nook/Thomson Precision Actuators are ruggedly designed for continuous duty and a long service life. They incorporate a direct drive or toothed belt drive for high mechanical efficiency that allows for a quiet running performance. They are supplied with either a ball screw or acme screw, and either a servo or stepper drive system.

Nook/Thomson can provide a complete system from one source including motor, drive, controller, and power supply.

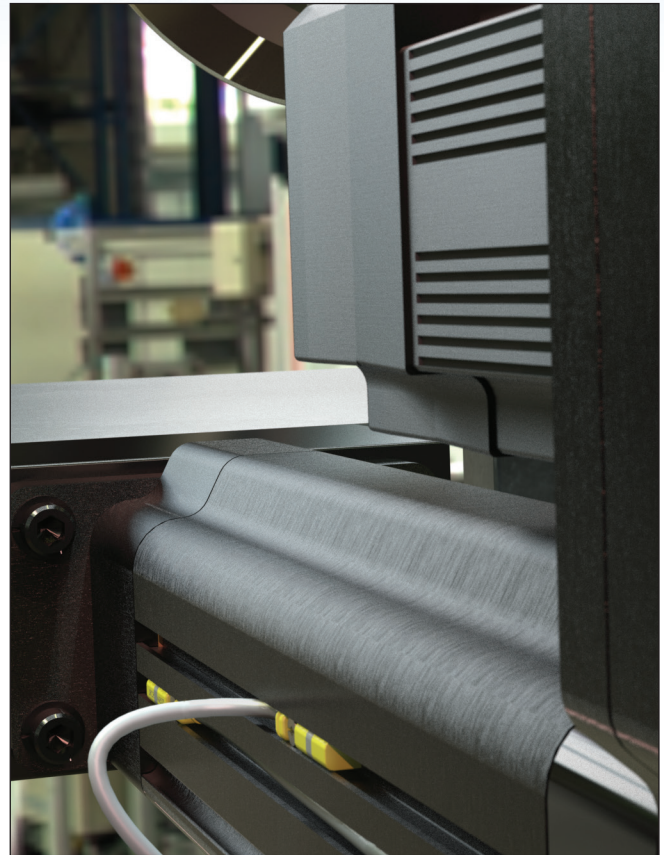



PA ACTUATOR™

DIMENSIONS

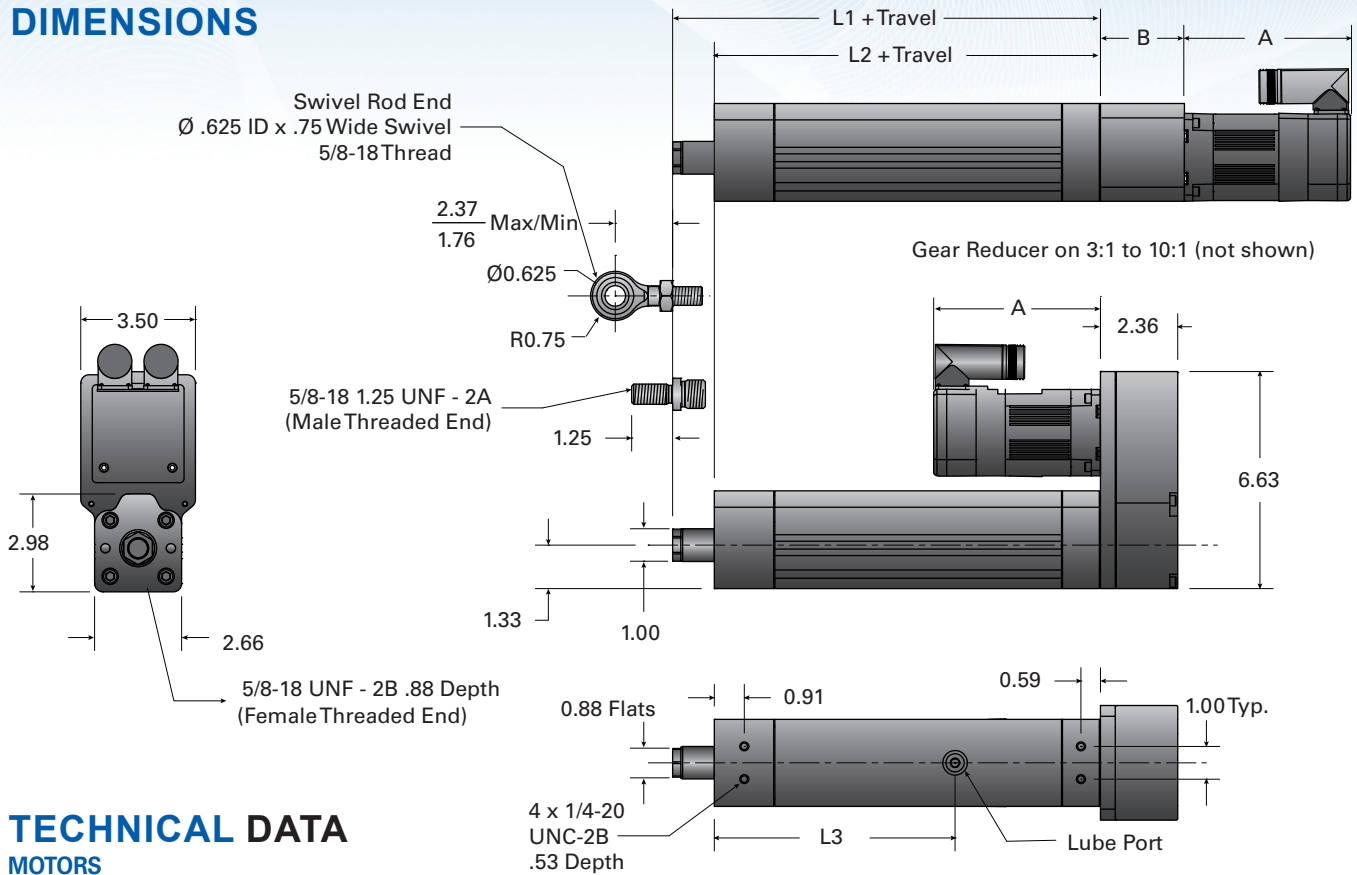

TECHNICAL DATA MOTORS

MOTOR	A (in)				B (in)	
	Without Reducer		With Reducer		Without Reducer	With Reducer
	No Brake	Brake	No Brake	Brake		
T23 STEPPER	3.03	n/a	5.49	n/a	2.36	2.61
T34 STEPPER	4.96	n/a	8.29	n/a	2.86	3.42
V200/400	5.42	6.96	8.09	9.62	2.44	2.61

NOTE: When using a linear position transducer, add 0.82 in to values L1, L2, and L3.

BALL SCREW MODELS

Screw	PERFORMANCE SPECIFICATIONS						DIMENSIONS		
	Lead (in)	Lead Accuracy (in/ft)	Efficiency (%)	Nut Max Velocity* (in/min)	Max Capacity (lb)	Dynamic Load** (lb)	L1 (in)	L2 (in)	L3 (in)
0750-0200	0.200	0.004	>90	800	1,000	2,200	9.05	7.78	7.34
0750-0500	0.500	0.004	>90	2000	1,000	2,723	10.10	8.83	8.40
0631-1000	1.000	0.004	>90	3000	620	620	9.05	7.78	7.34

* as limited by DN value

** Ball screw L_{10} life based on 1×10^6 inches of travel life

ACME SCREW MODELS

Screw	PERFORMANCE SPECIFICATIONS				DIMENSIONS		
	Lead (in)	Lead Accuracy (in/ft)	Efficiency (%)	Max Capacity (lb)	L1 (in)	L2 (in)	L3 (in)
3/4-6	0.166	0.0036	36	1,000	9.05	7.78	7.34
3/4-10	0.100	0.0036	25	1,000	9.05	7.78	7.34

* as limited by PV value

REFERENCE NUMBER SYSTEM

PA05-P — 03 / 0631-1000 SRT RA / V200B-G3 / BC / 12 / ANS

MODEL

PA05-P = Parallel
PA05-I = In-Line

GEAR RATIO

01 = 1:1
15 = 1.5:1 (parallel style only)
02 = 2:1 (parallel style only)
03 = 3:1
04 = 4:1
05 = 5:1
07 = 7:1
10 = 10:1

SCREW SIZE

BALL SCREW MODELS

0750-0200 SRT RA
0750-0500 SRT RA
0631-1000 SRT RA

ACME SCREW MODELS

076-RA = 3/4-6 RA
070-RA = 3/4-10 RA

MOTOR

T23 = Stepper NEMA 23 without Brake
T23B = Stepper NEMA 23 with Brake
T34 = Stepper NEMA 34 without Brake
T34B = Stepper NEMA 34 with Brake
V200 = Servo 200V without Brake
V200B = Servo 200V with Brake
V400 = Servo 400V without Brake
V400B = Servo 400V with Brake
SPC = Custom Motor

DRIVE OPTIONS

STEPPER ONLY

120V = 110VAC Input, 8.2A Output

SERVO ONLY

00 = No Drive Options
D0 = Indexing Drive
G0 = Integrated Drive
D3 = Indexing Drive w/ 3m Cable
G3 = Integrated Drive w/ 3m Cable
D9 = Indexing Drive w/ 9m Cable
G9 = Integrated Drive w/ 9m Cable
03 = 3m Cable Only
09 = 9m Cable Only
E = I/O Terminal Expansion Block
XX = Custom Drive

BASE END MOUNTING

B = Base Mount w/ Tapped Holes (Standard)
R = Rear Trunnion Mount
F = Front Trunnion Mount
G = Front Flange Mount
C = Base Male Clevis (Parallel Style Only)
D = Base Female Clevis (Parallel Style Only)

ROD END MOUNTING

C = Rod Clevis
T = Male Threaded End 5/8-18
H = Female Threaded End 5/8-18

TRAVEL

04 = 4 inches
06 = 6 inches
08 = 8 inches
10 = 10 inches
12 = 12 inches
18 = 18 inches
24 = 24 inches

MODIFIER LIST

A = Analog Linear Position Sensor
D = Digital Linear Position Sensor
N = Limit Sensors (NPN)
P = Limit Sensors (PNP)
B = Protective Boot for Actuator Tube
S = Standard
M = Modified

SENSORS

Nook/Thomson sensors are designed to meet the need for low cost position sensing on the PA Actuator™. It is highly accurate, with sensor repeatability up to ± .004" (0.1MM). This design allows users to install and adjust multiple sensors on a single actuator and integrate easily with a motion control system.

The sensor system is supplied with two PNP or NPN (normally closed) switches. For additional switches or to order a normally open switch, contact Nook/Thomson Application Engineers.

Nook/Thomson sensors are designed to allow easy field adjustments. Magnets are secured to the extension tube to ensure a positive response once it passes near the position sensor. To adjust the position sensors simply position the extension tube in the correct position, loosen the locking screw, and then slide the movable sensor to the desired location until the sensor indicates a response. Additional sensors can be added or moved. It is also possible to add multiple sensors to the same slot.

DC rated operational voltage:	10-30 VDC
DC rated operational amperage:	≤ 150 mA
Operating temperature:	-13°F to +158°F

HOW TO ORDER SENSORS

EXAMPLE:

PA05-P-03 / 0631-1000 SRT RA / V200B-G3 / BC / 12 / **ANS**

P = PNP
 N = NPN



LINEAR POSITION TRANSDUCER

BENEFITS

- Non-Contact - No wear, such as found with pot wipers on conductive mylar, particularly when mounted on dithered actuators or vibrating installations
- Low Power Needs - Allows use with printed circuit-level supplies of +24 VDC
- No Drift - No periodic re-calibration needed
- Continuous absolute position measurement

ANALOG

OUTPUTS

Resolution: Infinite (limited by ripple on the power supply)
 Repeatability: < ±0.005% full stroke
 Outputs: 0 - 10 VDC

ELECTRONICS

Operating voltage: 24 VDC
 Supply Current: 50-140 mA (stroke dependent)

DIGITAL

OUTPUTS

Resolution: 100 µm, 10 µm, 5 µm (controller dependant)
 Repeatability: < ±0.005% full stroke
 Outputs: Pulse (start/stop)
 RS-422 differential signal

ELECTRONICS

Operating voltage: 24 VDC
 Supply Current: 50-100 mA (stroke dependent)

NOTE: When using a linear position transducer, add 0.82 in to values L1, L2, and L3 to the chart on page 94.

M12 5-PIN CONNECTOR



1	+24 Vdc
2	Output signal
3	DC ground (for power return)
4	No Connection
5	Ground for signal return

M12 8-PIN CONNECTOR



1	(+) Start
2	(-) Start
3	(+) Stop
4	(-) Stop
5	No Connection
6	No Connection
7	+24 VDC
8	DC Ground for power return

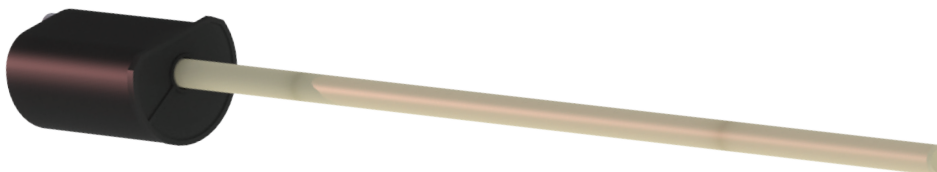
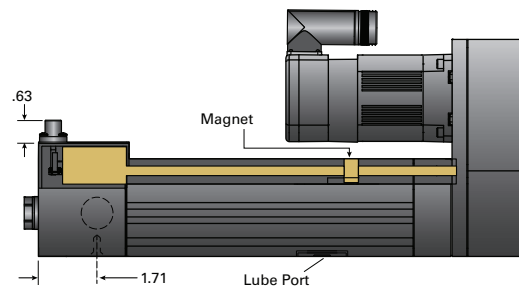

ACCESSORIES

REAR TRUNNION MOUNT

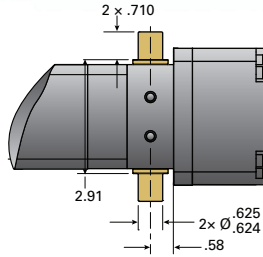

FRONT TRUNNION MOUNT

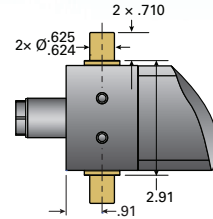
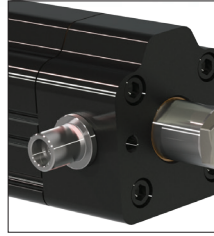

REAR MALE CLEVIS MOUNT

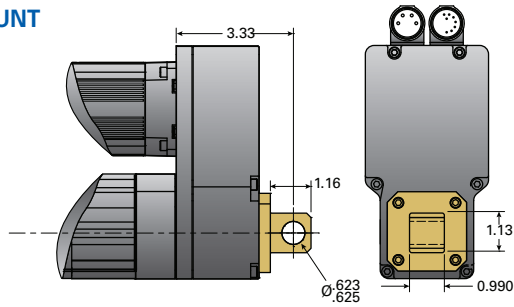
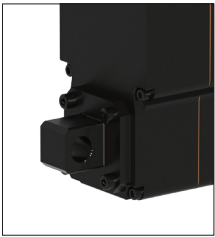

REAR FEMALE CLEVIS MOUNT*

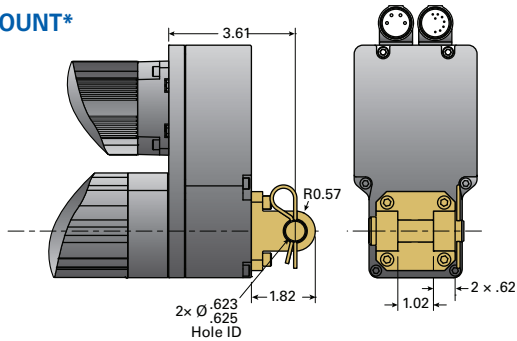

* 5/8" diameter clevis pin and re-usable cotter pin included

FRONT FLANGE

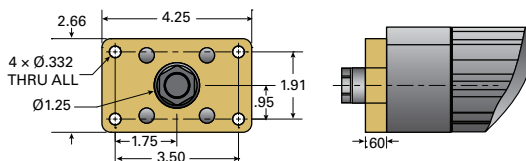
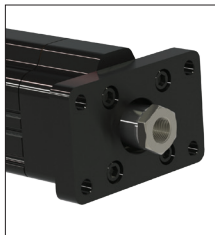

SPEED LOAD CURVES
0750-0200 BALLSCREW

V400(B) SERVO MOTOR

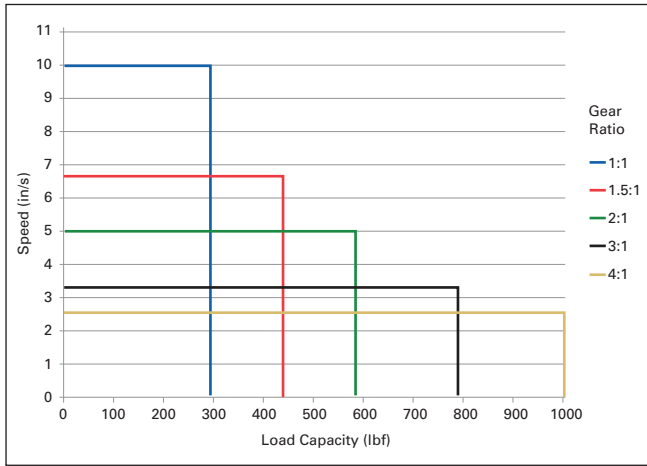

V200(B) SERVO MOTOR

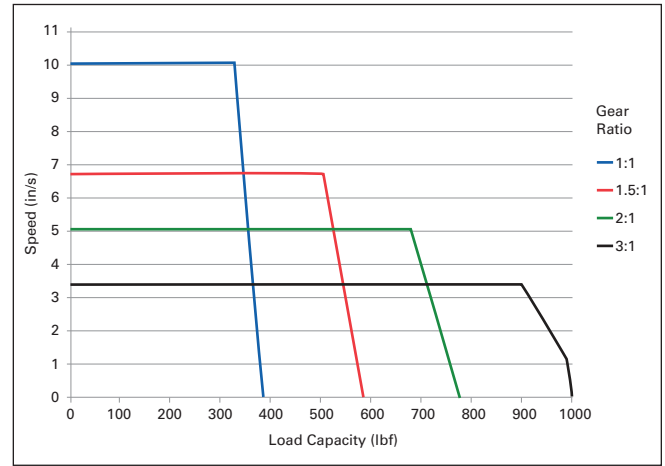

T34 STEPPER MOTOR

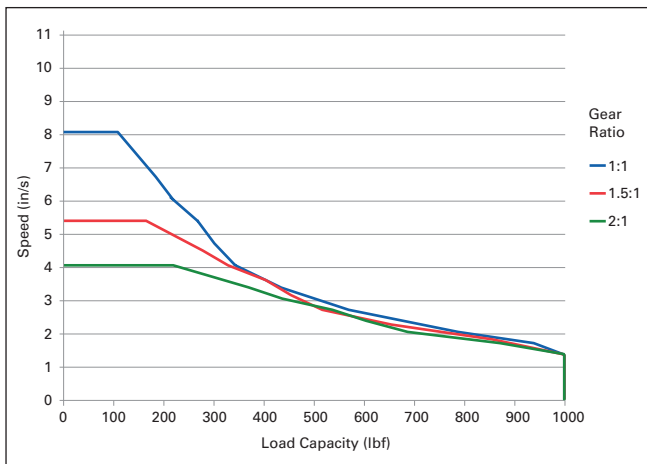

T23 STEPPER MOTOR

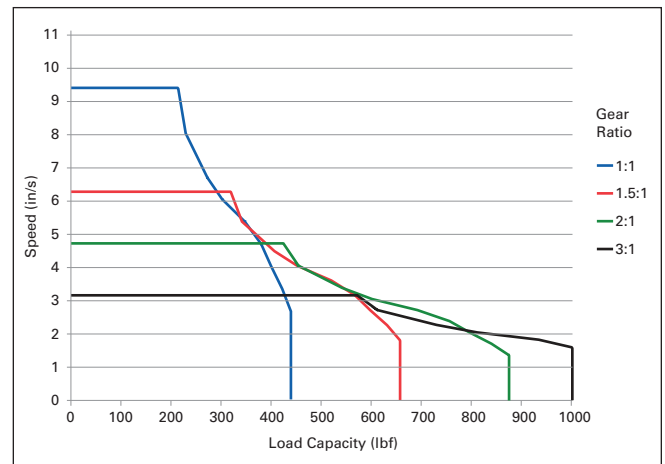

CAUTION: motor input current must be considered to ensure that the actuator maximum capacity is not exceeded

PA ACTUATOR™

SPEED LOAD CURVES

0750-0500 BALLSCREW

V400(B) SERVO MOTOR

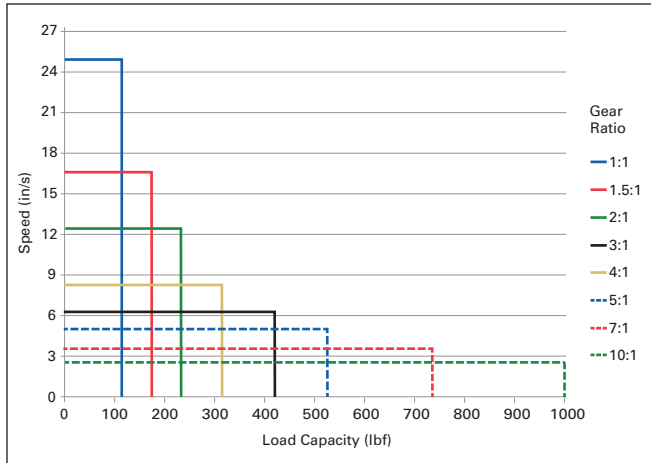

V200(B) SERVO MOTOR

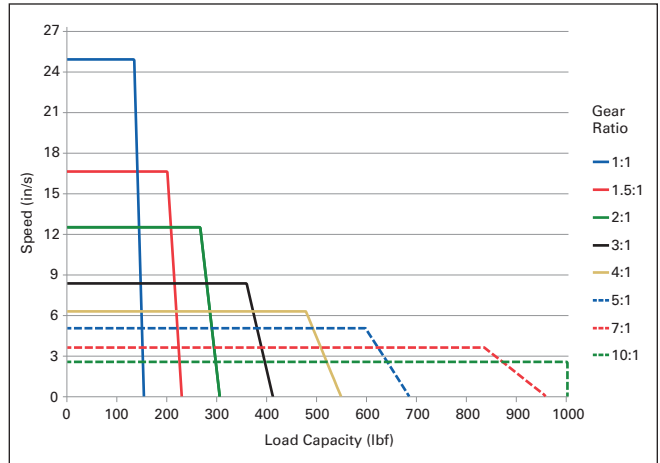

T34 STEPPER MOTOR

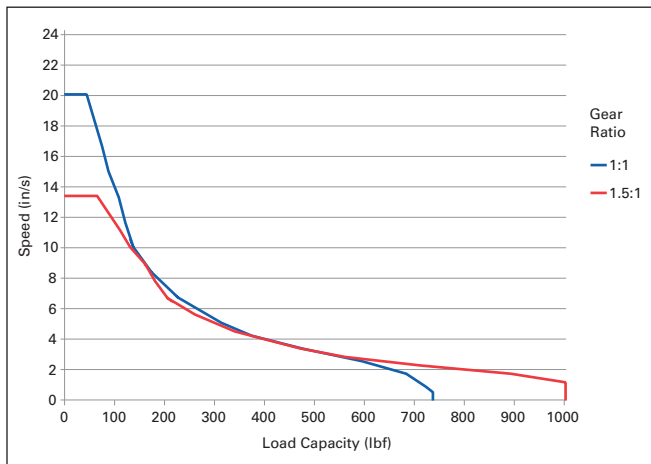

T23 STEPPER MOTOR

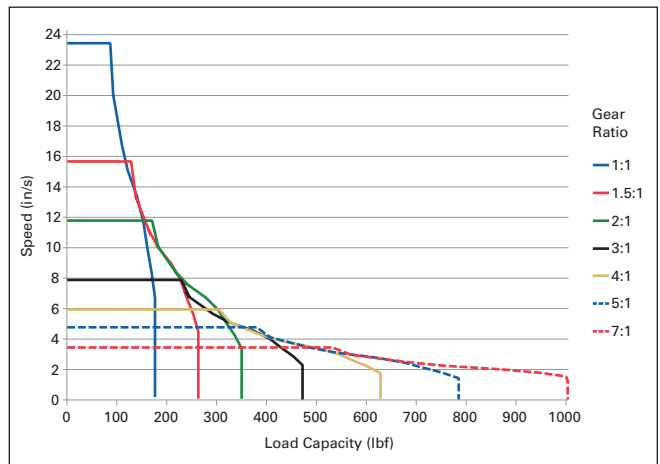

CAUTION: motor input current must be considered to ensure that the actuator maximum capacity is not exceeded

SPEED LOAD CURVES
0631-1000 BALLSCREW

V400(B) SERVO MOTOR

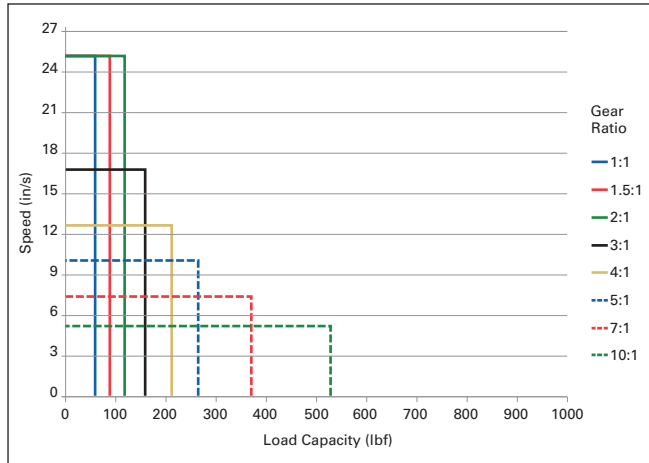

V200(B) SERVO MOTOR

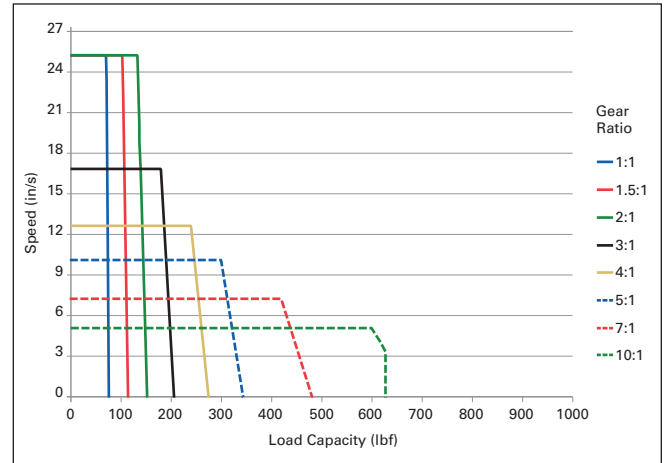

T34 STEPPER MOTOR

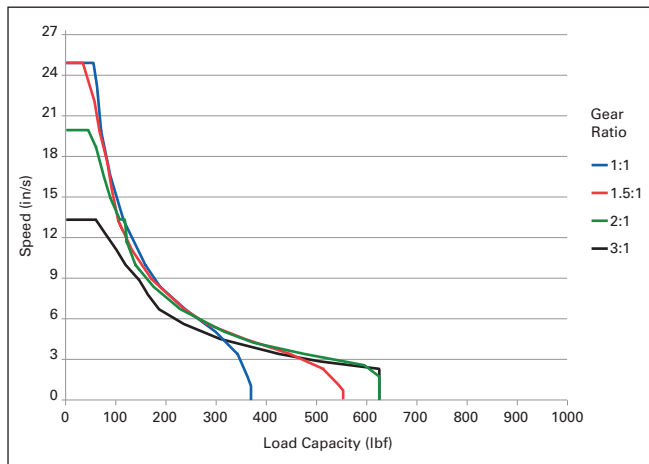

T23 STEPPER MOTOR

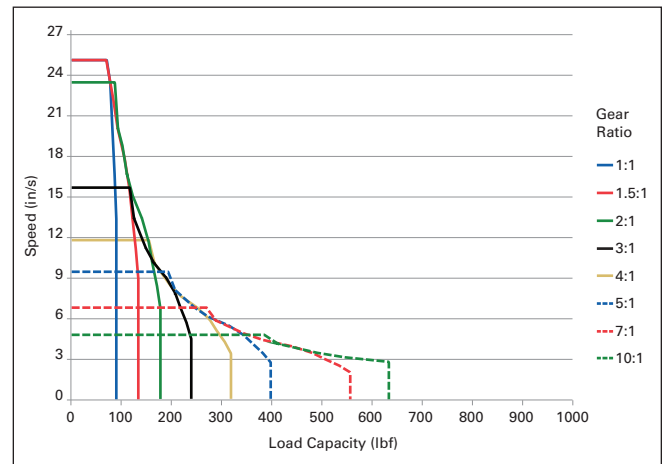

CAUTION: motor input current must be considered to ensure that the actuator maximum capacity is not exceeded

PA ACTUATOR™

SPEED LOAD CURVES

3/4-10 ACME SCREW

V400(B) SERVO MOTOR

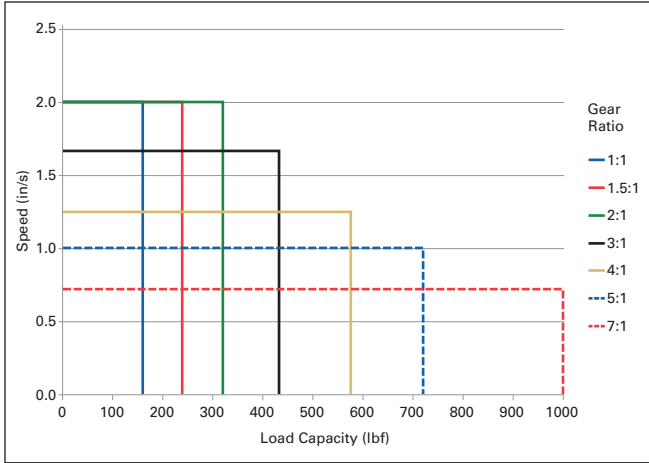

V200(B) SERVO MOTOR

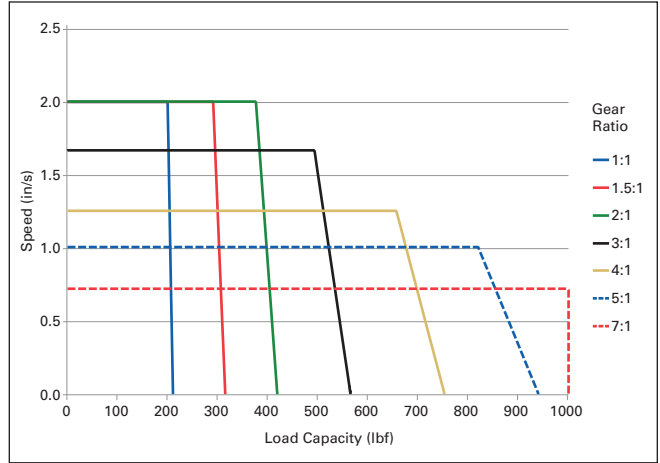

T34 STEPPER MOTOR

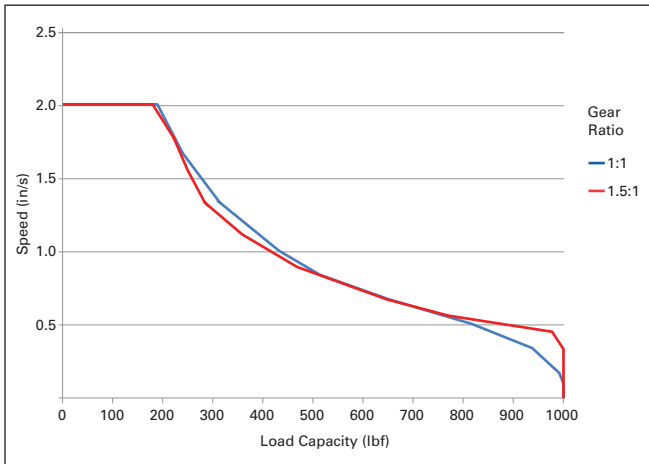

T23 STEPPER MOTOR

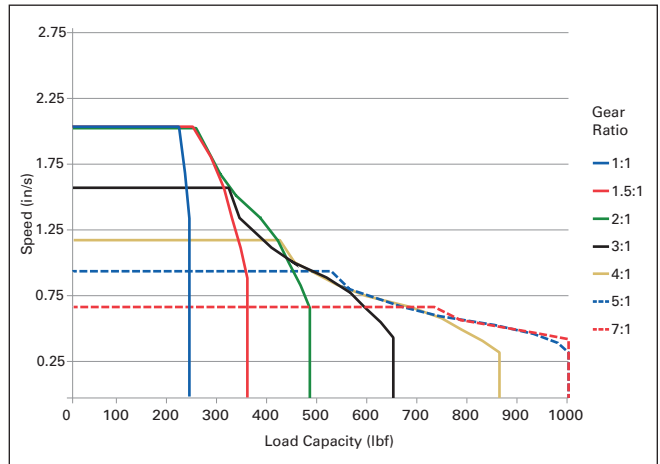

CAUTION: motor input current must be considered to ensure that the actuator maximum capacity is not exceeded

SPEED LOAD CURVES

3/4-6 ACME SCREW

V400(B) SERVO MOTOR

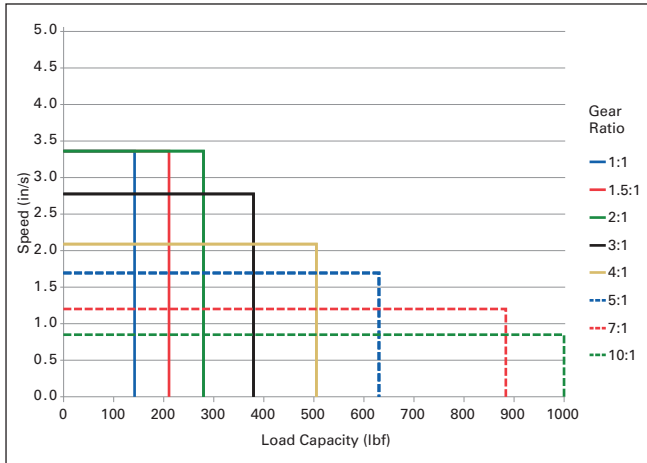

V200(B) SERVO MOTOR

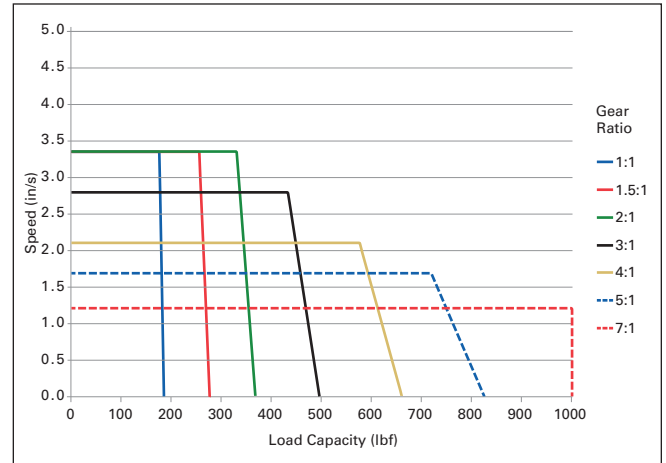

T34 STEPPER MOTOR

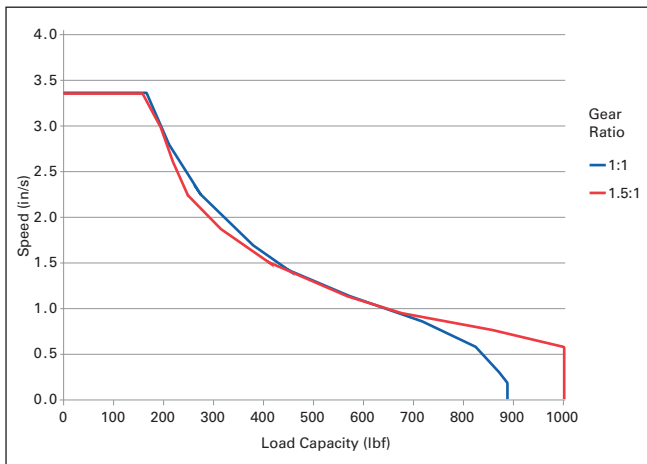

T23 STEPPER MOTOR

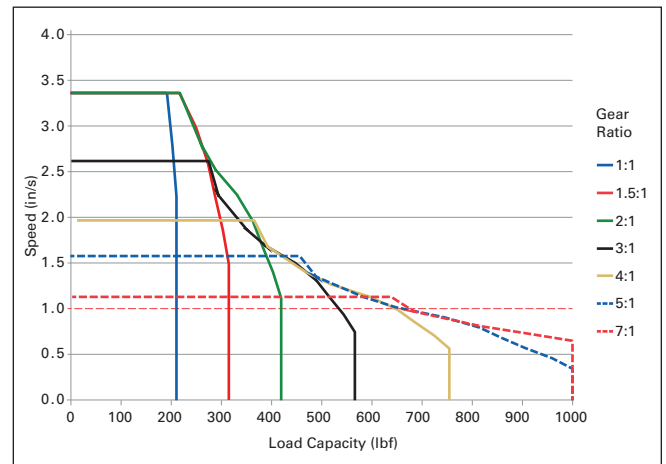

CAUTION: motor input current must be considered to ensure that the actuator maximum capacity is not exceeded

PA ACTUATOR™

PRECISION LINEAR ACTUATORS



Nook/Thomson Linear Actuators are used in many agricultural applications.



CC™ SERIES COMPACT CYLINDER

CC™ COMPACT CYLINDER 104-123

Inside the CC™ Cylinder	106-107
Introduction	108
Reference Number System	109
Technical Data	110-113
Accessories	114-122
Motor Diagram & 110 Vac Adapter	123
Setting Limit Switches	123

INSIDE THE CC™ CYLINDER

HIGH PERFORMANCE, LOW COST, POSITIONING SYSTEM

3000 LB. STATIC CAPACITY

BRAKE

The load sensitive brake maintains the actuator's position when at rest, without consuming power. (Ball Screw models only)

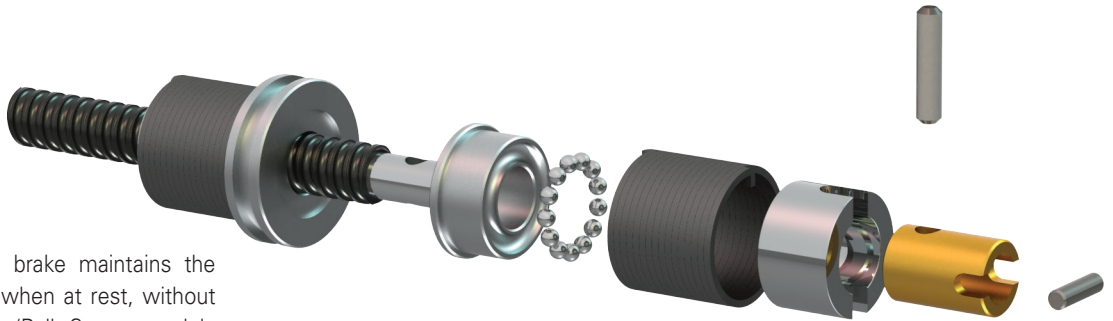

MOUNTING ENDS

The CC™ Linear Actuator can be fitted with multiple mounting arrangements including a variety of clevis and mounting ends.

- 1/2" Bolt
- 1/2" Spherical Rod Eye
- 1/2" Clevis End
- 1/2" Threaded Rod End

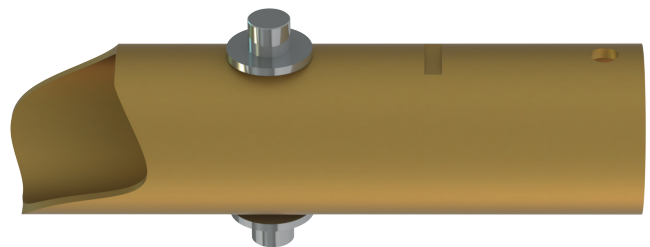
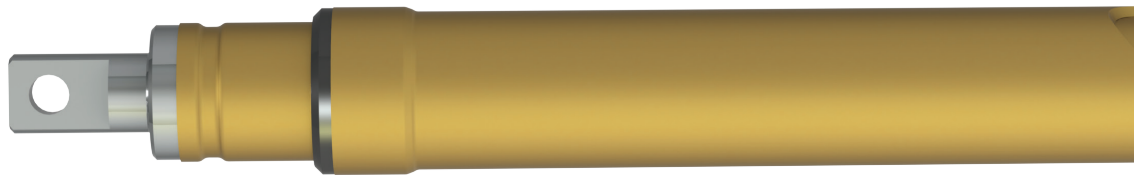

BASE MOUNTS

A variety of mounting brackets and optional trunnion mounts are available.

MOTORS

The CC™ Linear Actuator offers a variety of AC and DC motors including an optional stepper motor.

12 VDC
24 VDC
36 VDC
90 VDC
110 VAC
Stepper

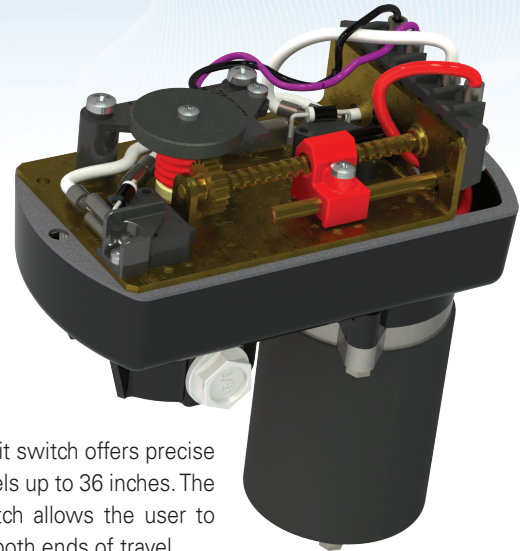

LIMIT SWITCH

The screw type limit switch offers precise positioning for travels up to 36 inches. The design of this switch allows the user to easily set limits at both ends of travel

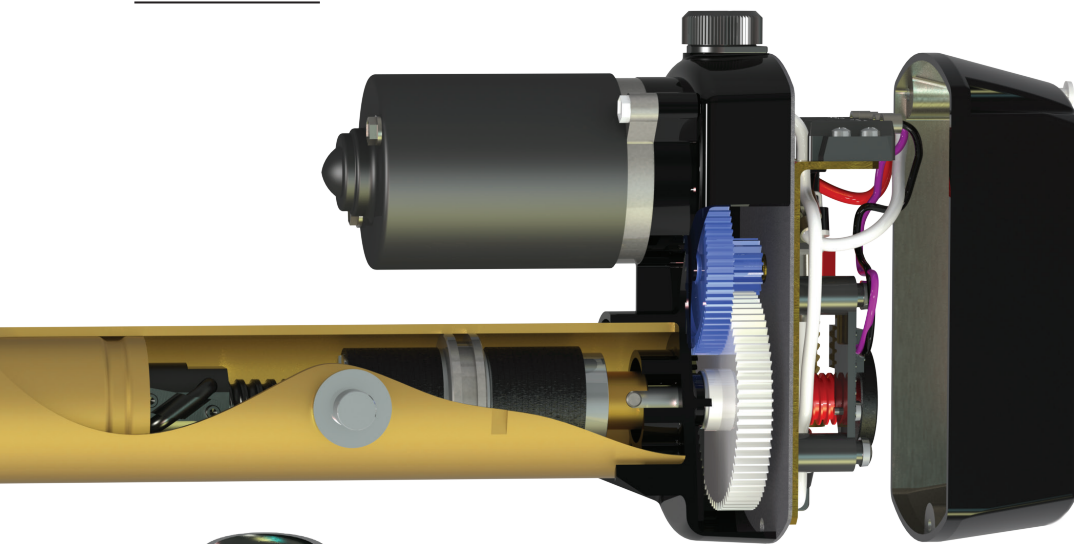

GEAR RATIOS

The CC™ Linear Actuator is fitted with either a belt drive or multiple gear ratios.

18:1 GEAR
19:1 BELT
28:1 GEAR
58:1 GEAR



Ball Nut

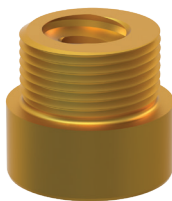

Acme Nut

LIFTING SCREW

Optional acme and ball screw lead and diameters are available.

5/8-5 Acme Screw
0631-0200 Ball Screw
0631-0500 Ball Screw (no brake available)*
0750-0200 Ball Screw (no brake available)*

* optional

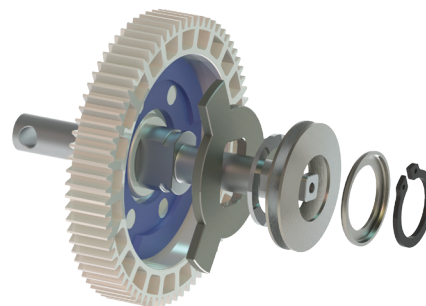

CLUTCH

The CC Linear Actuator gear head offers a heavy-duty clutch that protects the gears and components in the event of overload or overtravel. Not available with belt drive.

INTRODUCTION

CC™ CYLINDERS

Nook/Thomson CC™ Actuators are a combination of an electric motor and an acme screw or a high efficiency ball screw. They are designed to be ready to install directly into any industrial or commercial application. They are ideally suited for any OEM application where linear motion is needed. These high-quality actuators feature:

- Durable construction
- Dependable performance
- Long-life operation
- High repeatability
- Operation in either compression or tension loading applications
- Adjustable limit switches
- Lifetime lubrication
- Mechanical overload protection
- Corrosion resistant exterior surfaces

COMMON APPLICATIONS

- Telecommunications
- Architectural Automation
- Medical and Hospital Equipment
- Semiconductor
- Food Processing
- Farm Equipment
- Satellite Dish and Antenna Positioning

DUTY CYCLE

25%, max "on-time" of 5 minutes at rated load

TEMPERATURE RATING

Operating temperature range is -30°F to +160°F

ENVIRONMENTAL PROTECTION CLASS

- IP54



Nook/Thomson Linear Actuators used in a tire balancing machine.

REFERENCE NUMBER SYSTEM

CC - 18 - HD / C / 111 / AA / 24 / BS

MODEL

- CC = Standard Actuator
- CCT = T-Mounted Actuators
- CCU = U-Mounted Actuators

GEAR RATIO

- 18 = 18:1
- 19 = 19:1 (BELT - HD only)
- 28 = 28:1
- 58 = 58:1

SCREW

- HD = Ball Screw
- A8 = Acme Screw

VOLTAGE

- A = 12 VDC
- B = 24 VDC
- C = 36 VDC
- D = 90 VDC
- E = 110 VAC (with rectifier)
- F = 12 VDC HI SPEED
- H = Stepper

LIMIT SWITCH

- 0 = No Limit Switch
- 1 = Limit Switches
- 2 = Dual Limit Switches
(1 for motor shut-off, 1 for PLC control)

SENSOR

- 0 = No Sensor
- 1 = Reed Switch
- 2 = Hall Effect Sensor
- 3 = 10K Potentiometer
- 4 = Encoder (Specify PPR)

CLUTCH

- 0 = No Clutch
- 1 = Clutch (Standard)

TUBE MOUNTING

- A = Trunnion
- B = Heavy Duty In-Line Bracket
- C = Standard Tube Clamp
- D = Heavy Duty Tube Clamp
- E = Heavy Duty Long CS Clamp
- H = Heavy Duty Long Clamp
- J = Light Duty In-Line Bracket
- K = Heavy Duty In-Line Clamp
- L = Trunnion Clamp
- M = Trunnion Bracket
- N = Long Trunnion Bracket
- O = Side Trunnion Bracket

END MOUNTING

- A = 1/2" Flat
- B = 1/2" Swivel
- C = 3/4" Swivel
- D = 3/4"-10 Tapped Hole
- E = 1/2"-20 Tapped Hole
- H = 3/8"-16 Tapped Hole
- J = 5/8"-18 Tapped Hole

TRAVEL

In Inches.
Anything over 36", contact factory

MODIFIER LIST

- B = Bellows Boot
- Z = Motor Boot
- W = Wiper
- K = Keyed Tube
- S = Standard
- M = Modified

DIMENSIONS AND PERFORMANCE

BALL SCREW SERIES

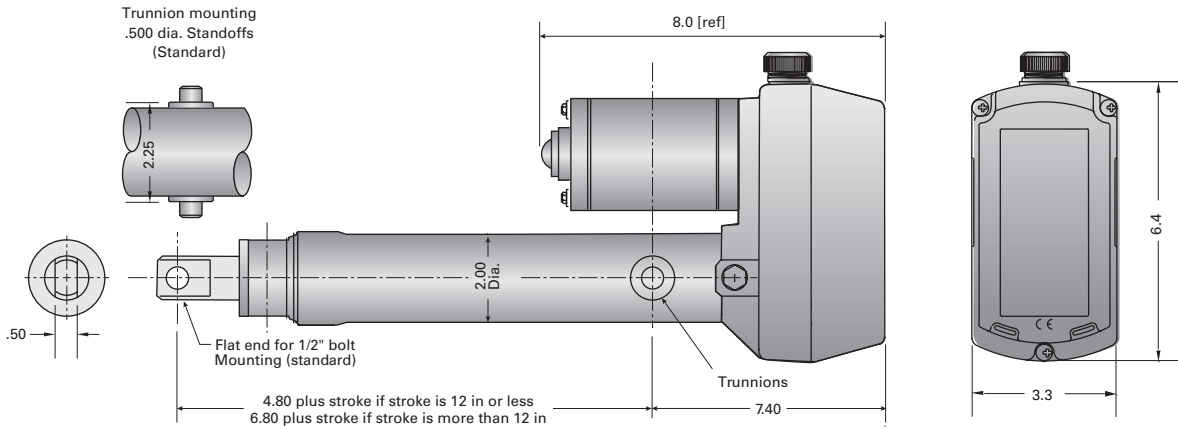

12VDC SPEED AMPS

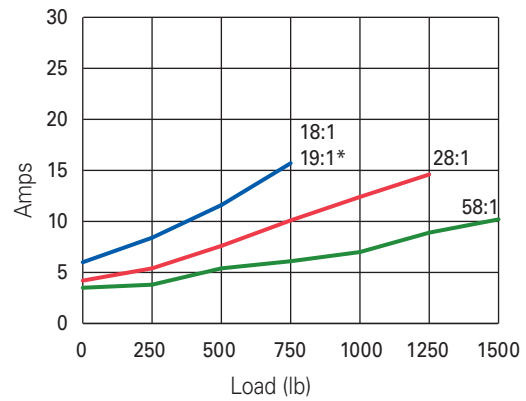
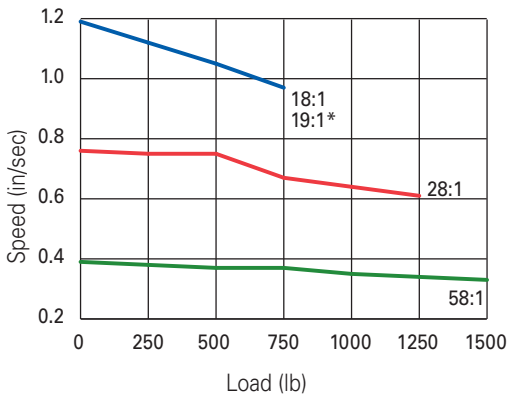

12VDC HI SPEED SPEED AMPS

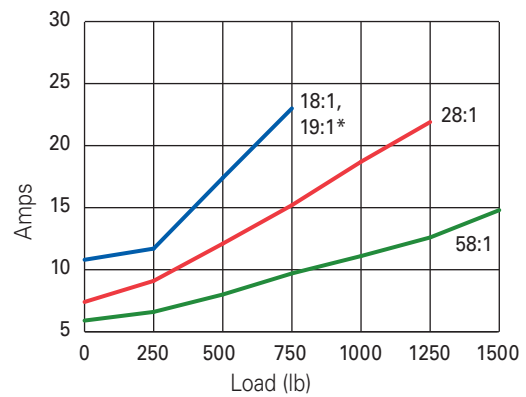
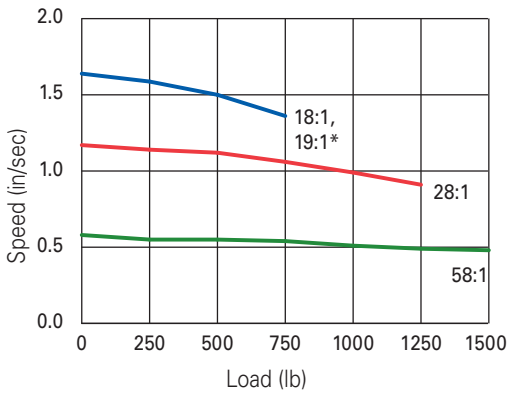

* Belt-driven

24VDC SPEED AMPS

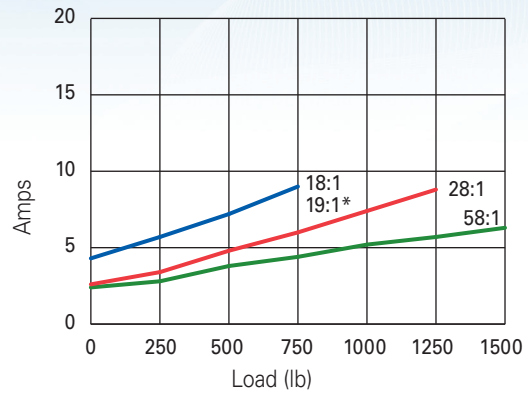
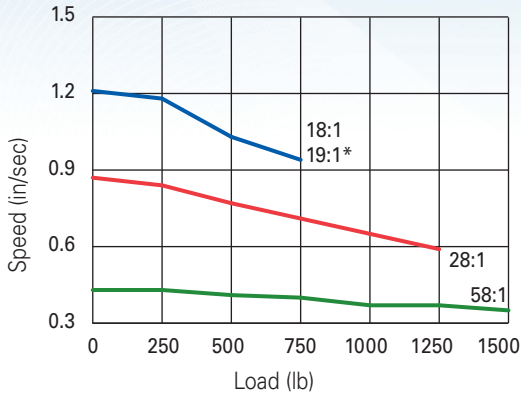

36VDC SPEED AMPS

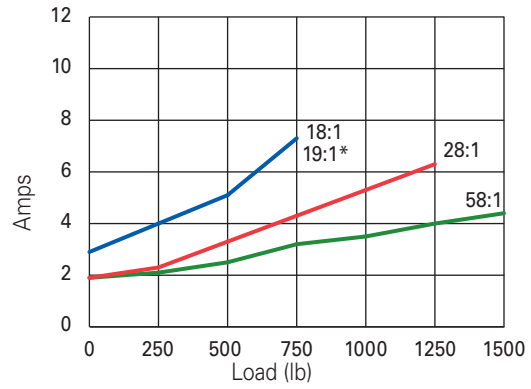
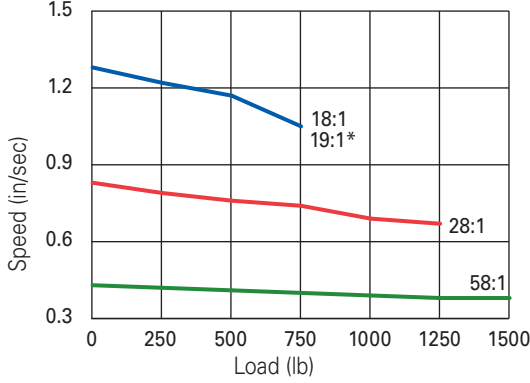

90VDC SPEED AMPS

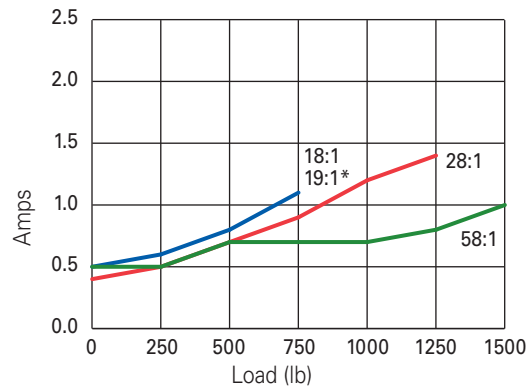
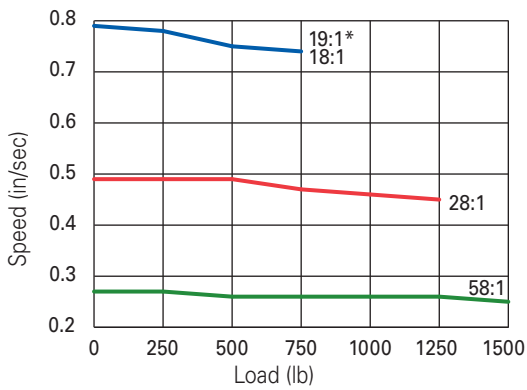

110VAC SPEED AMPS

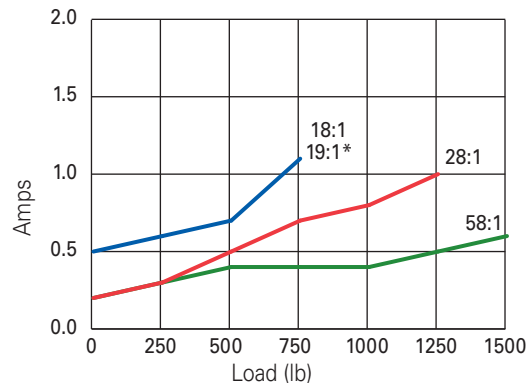
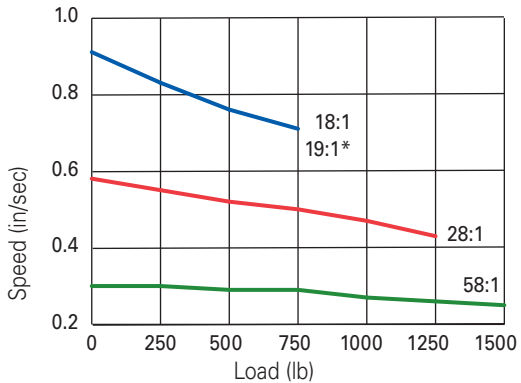

CC™ CYLINDER

DIMENSIONS AND PERFORMANCE

ACME SCREW SERIES

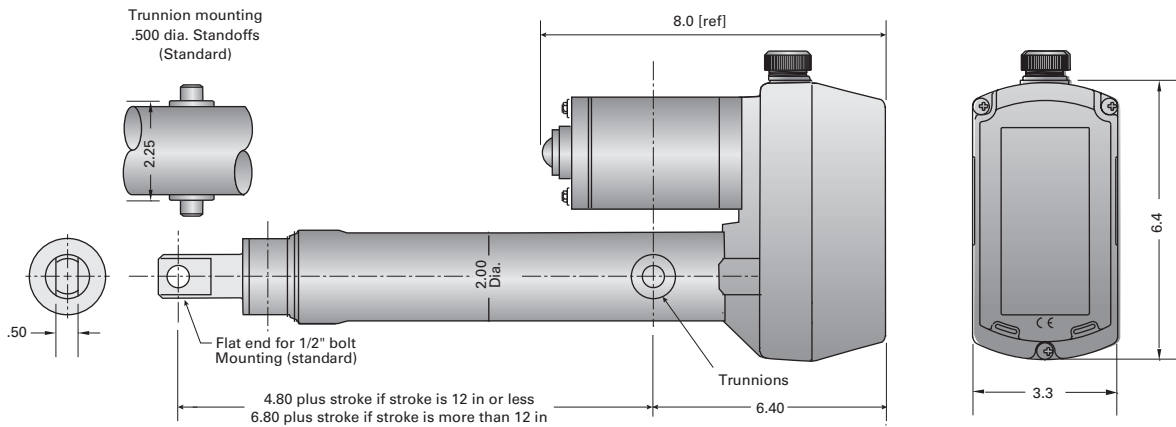
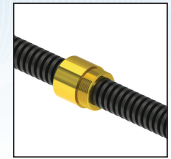

12VDC SPEED AMPS

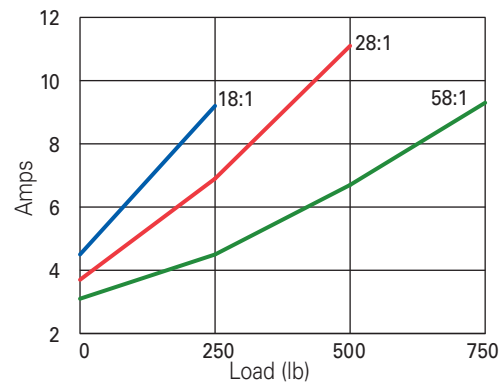
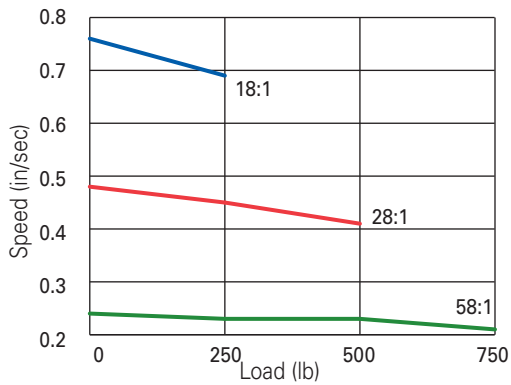

12VDC HI SPEED SPEED AMPS

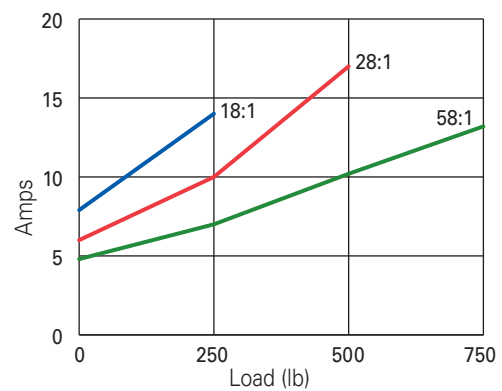
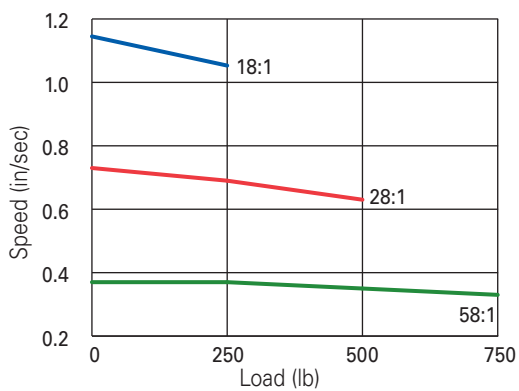

24VDC SPEED AMPS

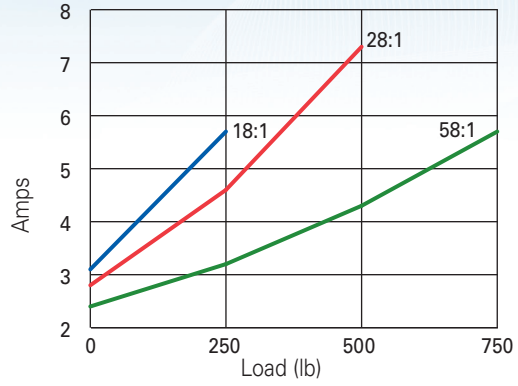
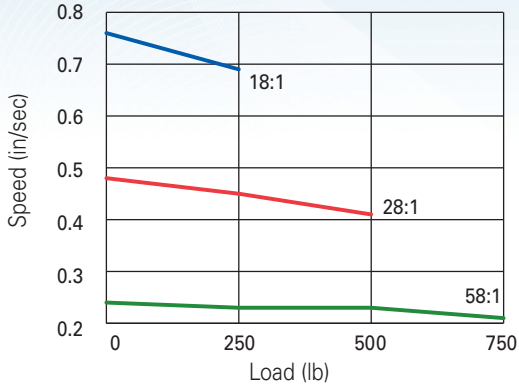

36VDC SPEED AMPS

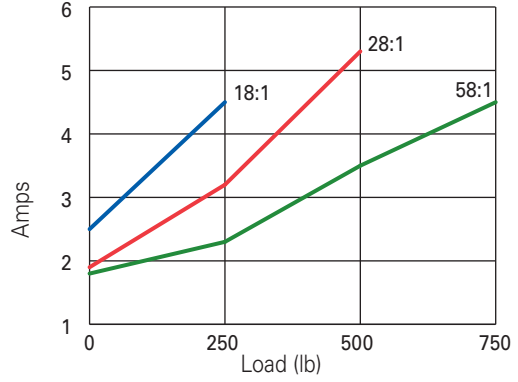
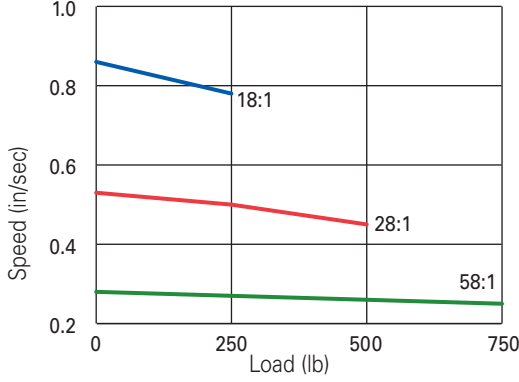

90VDC SPEED AMPS

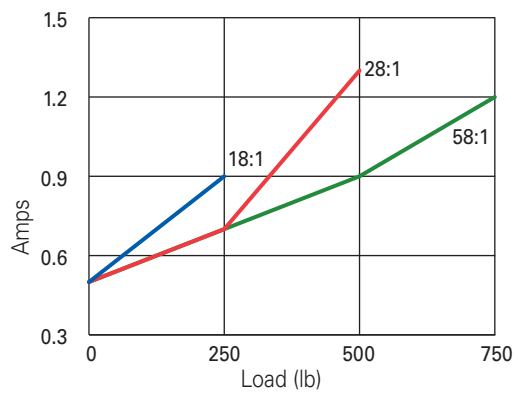
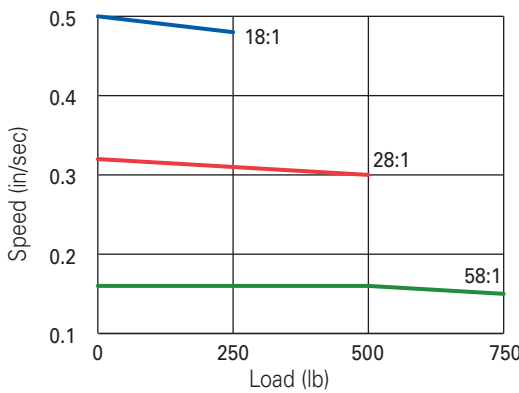

110VAC* SPEED AMPS

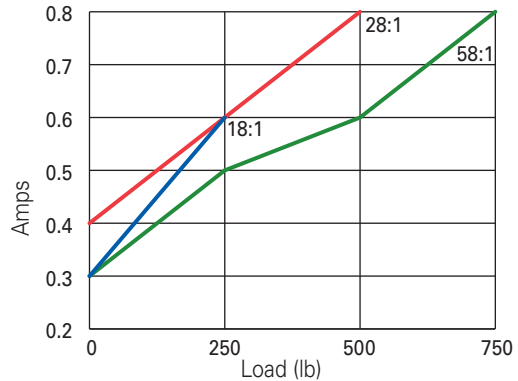
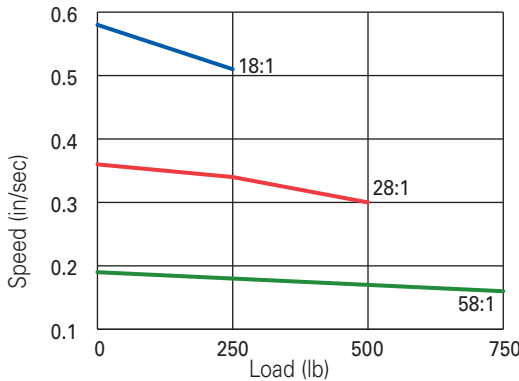

* 110Vac options is supplied with a 110Vdc motor and rectifier.

ACCESSORIES

Nook/Thomson offers a variety of accessories that are specifically designed for the CC™ Actuators. There are several mounting options to choose from, including two tandem configurations. Limit switch and sensor options, as well as control devices are also available. The CC™ Actuator can be provided with boot covers for environmental protection for both the extension tube and for the motor gear box.

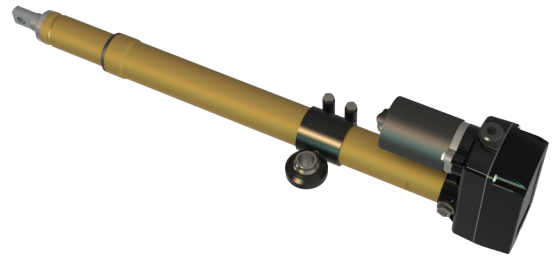

CLAMPS
Page 116

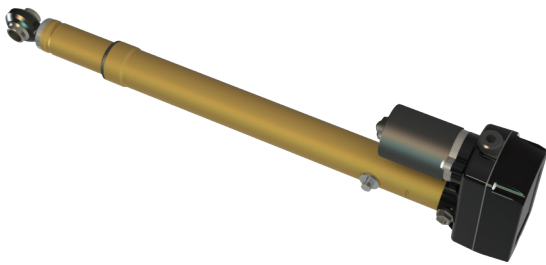

ROD ENDS
Page 119



U MOUNT
Page 120

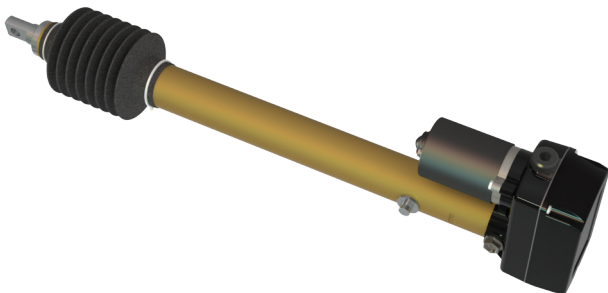

BELLOWS BOOTS AND MOTOR BOOTS
Page 121

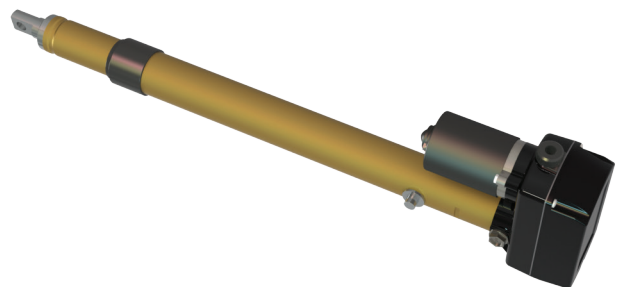

WIPERS
Page 121

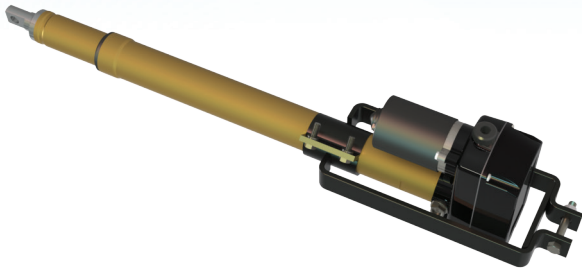

BRACKETS

Page 117

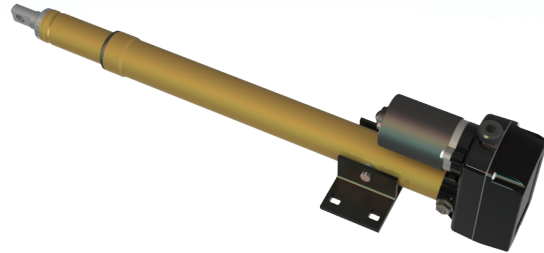

TRUNNION BRACKETS

page 118

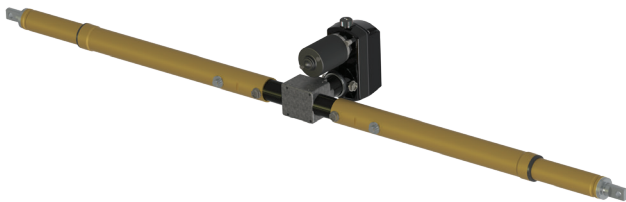

T MOUNT

Page 120

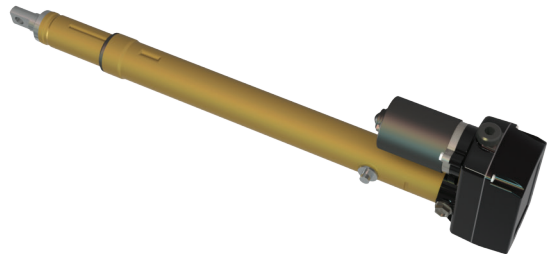

KEYED ACTUATORS

Page 121

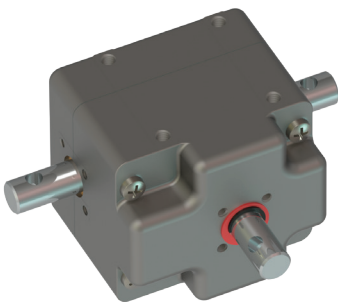

GEARBOXES

Page 121



SENSOR AND CONTROL OPTIONS

Page 122

CLAMPS

STANDARD CLAMP

Part Number: 818-20

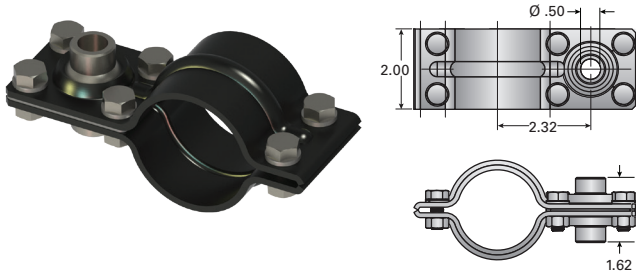

HEAVY DUTY LONG CLAMP

Part Number: 818-51

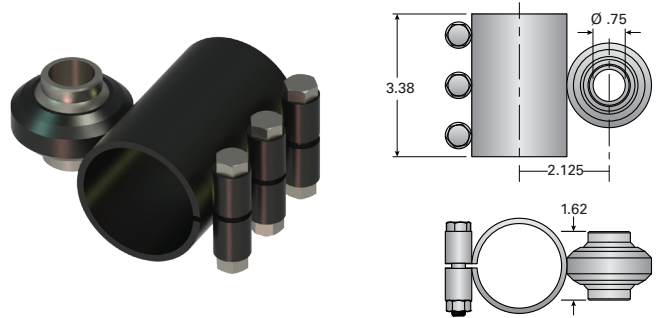

HEAVY DUTY CLAMP

Part Number: 818-50

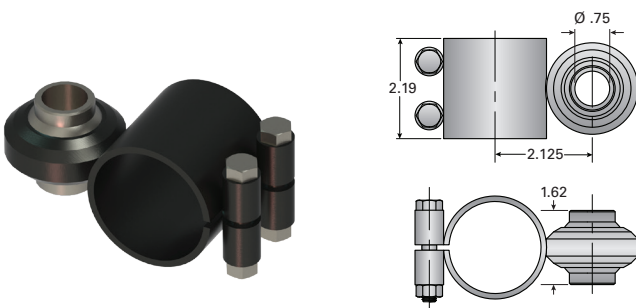

TRUNNION CLAMP

Part Number: 818-55

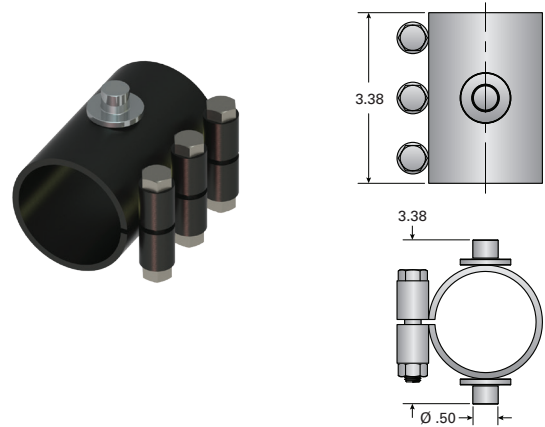

HEAVY DUTY LONG CS CLAMP

Part Number: 818-51CS

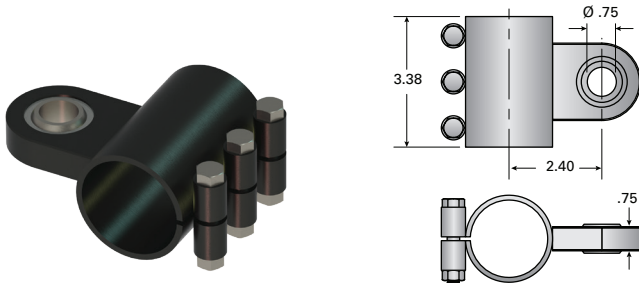

HEAVY DUTY IN-LINE CLAMP

Part Number: 818-52

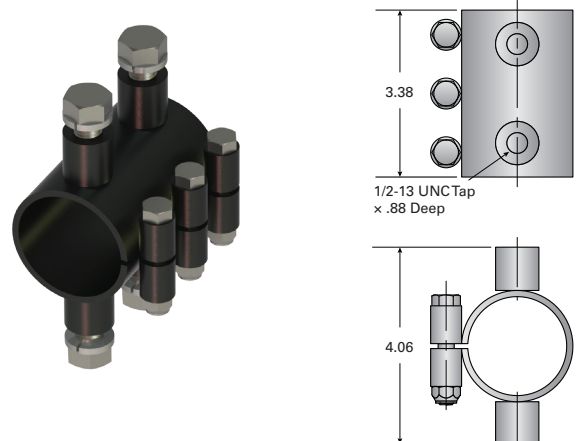

MOUNTING BRACKETS

HEAVY DUTY IN-LINE BRACKET

PART NUMBER: 844-52

For use with 1500 lb capacity units

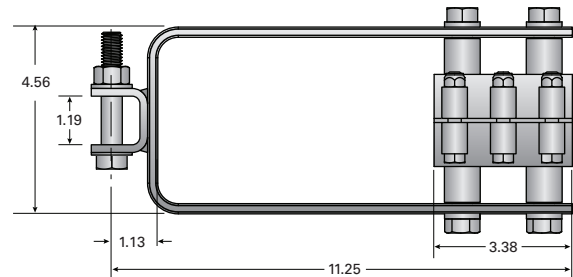
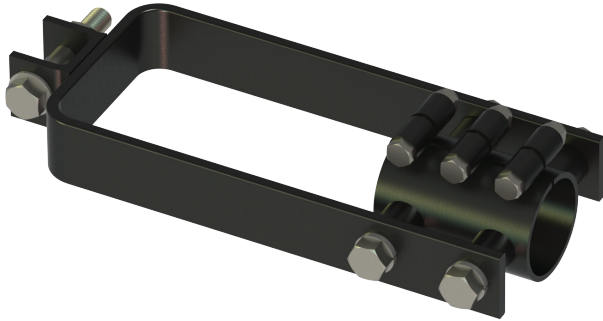

LIGHT DUTY IN-LINE BRACKET

PART NUMBER: 844-50

For use with 750 lb capacity units

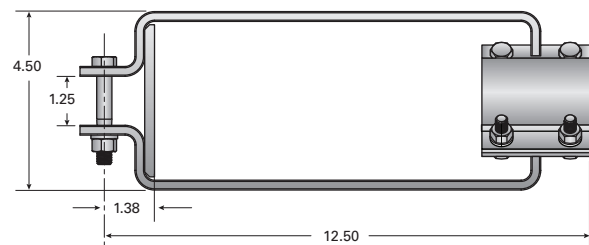

TRUNNION MOUNTING BRACKETS

TRUNNION BRACKET

Part Number: 846-20

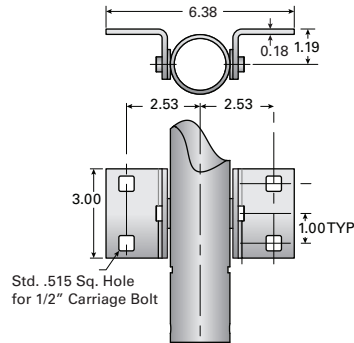
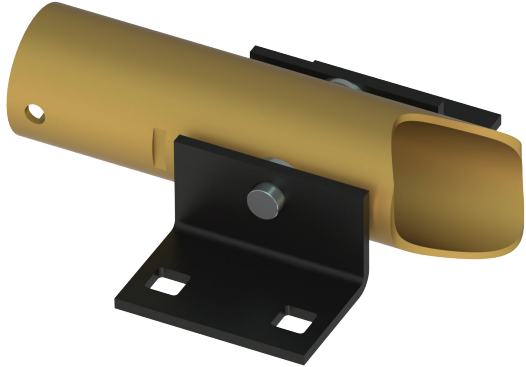

LONGTRUNNION BRACKET

Part Number: 846-21

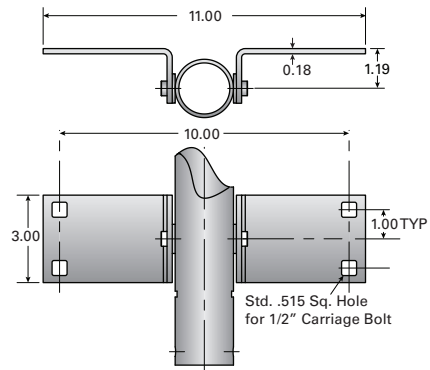
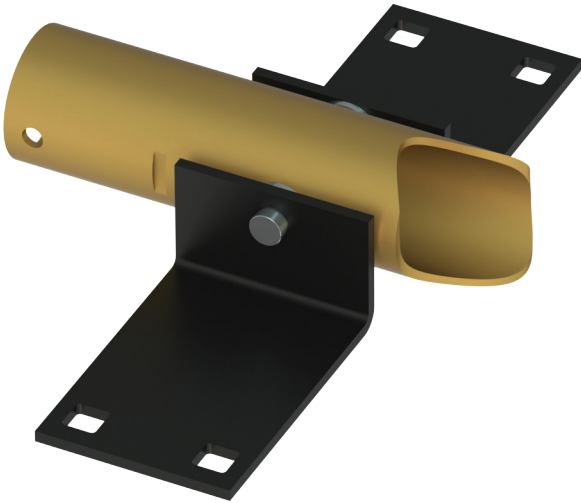

SIDETRUNNION BRACKET

Part Number: 846-22

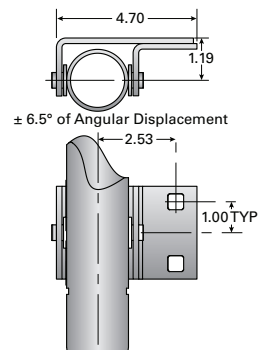
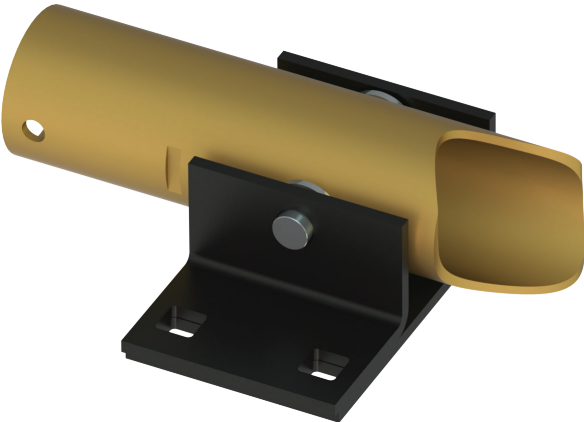

ROD END MOUNTING OPTIONS

CC Linear Actuators can be mounted with standard trunnions and clevis end. When double clevis mounting is required, an optional bracket is available.

MALE CLEVIS

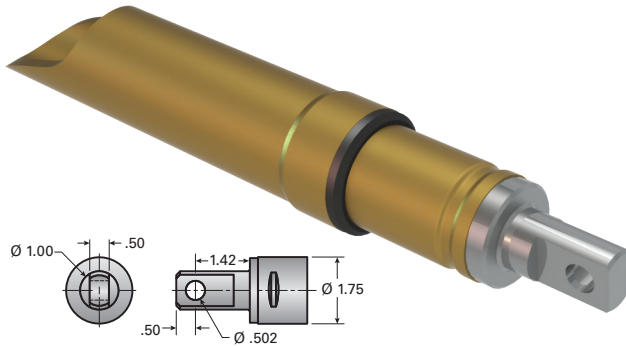

TAPPED HOLE

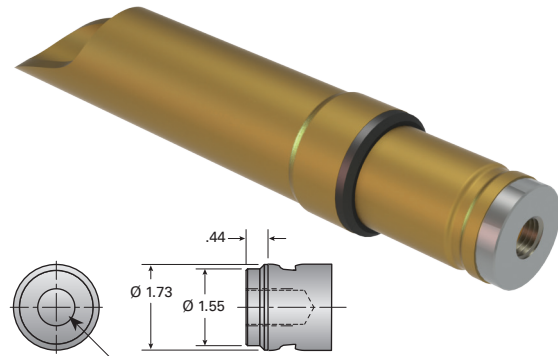

- 3/4-10 Tapped Hole
- 1/2-20 Tapped Hole
- 3/8-16 Tapped Hole
- 5/8-18 Tapped Hole

1/2" SWIVEL BALL END

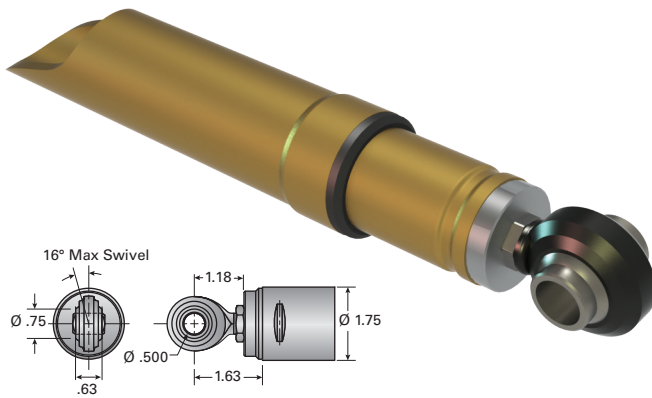

3/4" SWIVEL BALL END

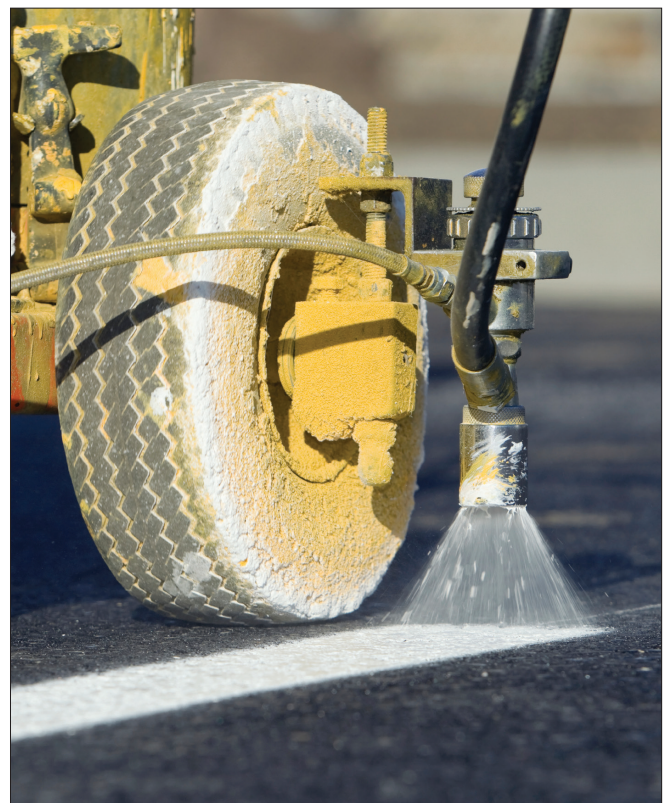
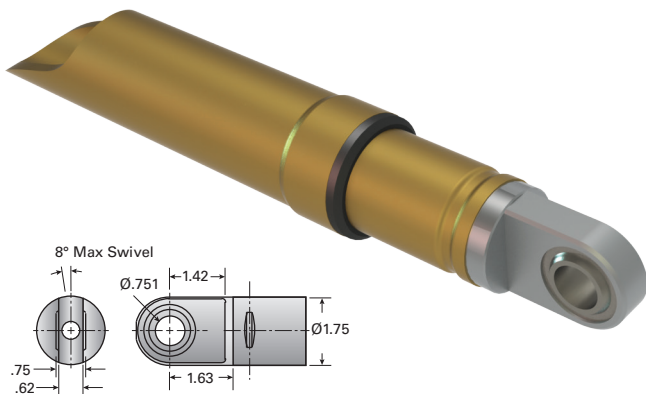

Nook Linear Actuators are used in many road maintenance applications.

U-MOUNT

U-Mount configuration is designed with two actuating cylinders that work in tandem providing a uniform synchronized motion in the same direction, with a single motor and gear box. The tandem mount can be field-adjusted to varying widths. Additional actuator rod can be added to accommodate longer arrangements.

The U-Mount comes with a standard width adjustment of 70" max to 48" min center to center of the actuator rods. An optional width adjustment can be provided giving an 82" max to 60" min from center to center of the actuator rods.

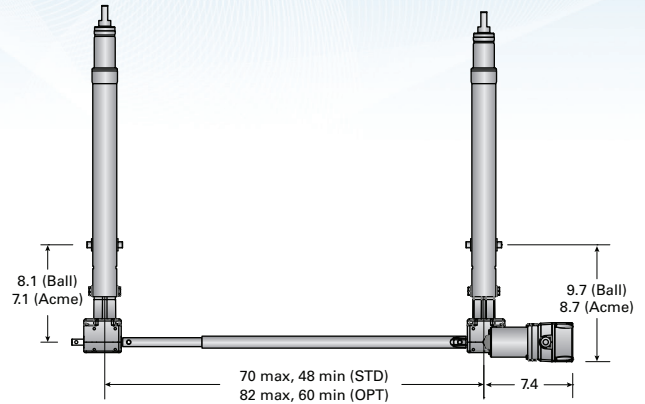
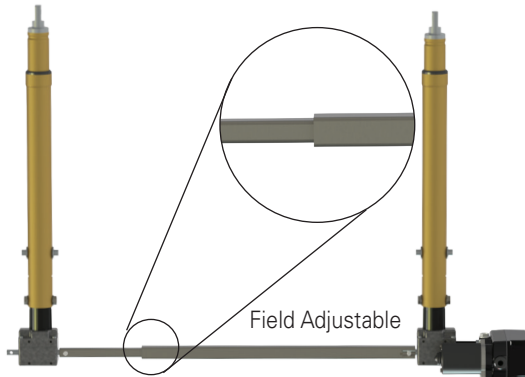

HOW TO ORDER A U-MOUNT CC™ CYLINDER

CCU18 - HD / C / 111 / AA / 24 / BS

U-Mount designation

T-MOUNT

T-Mount configuration is designed with two actuating cylinders that work in opposing directions. Both actuator rods are connected to the same motor and gear box providing a uniform synchronized motion in the opposite direction.

HOW TO ORDER A U-MOUNT CC™ CYLINDER

CCT18 - HD / C / 111 / AA / 24 / BS

T-Mount designation

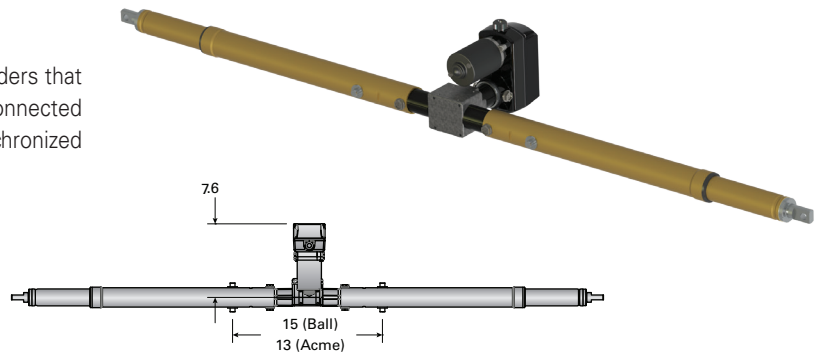

ALTERNATE GEARBOX ASSEMBLIES

CC Cylinders can also be fitted with a 1:1 Miter Gearbox, or a 5:1 or 20:1 Worm Screw Gear Box. Contact Nook/Thomson for alternate gearbox options.



Double Clevis, 5:1, 20:1

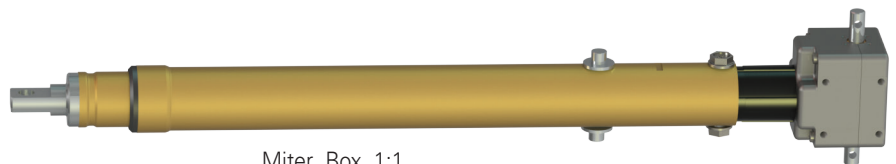

Miter Box, 1:1

KEYED ACTUATORS

The CC™ Actuator comes with a keyed option that allows an extension rod with an anti-rotation feature which will not allow the transmission of torque to the rod end mount. This is ideal for applications where load structures cannot accommodate torque loads.

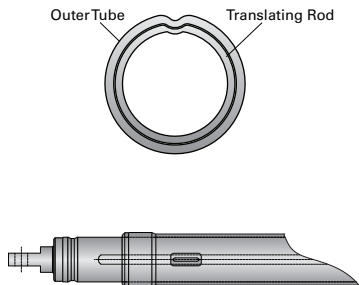

BOOTS

The CC™ Actuator can be fitted with a bellows boot to protect the extension tube from contamination.

Standard boots are molded for oil, water, and weather resistance and are furnished with tie straps. Tie straps are attached from convolution to convolution and help the boot extend uniformly.

A motor boot can be added to cover the gearbox and motor to protect them from the environment. The motor boot is made from a molded plastic that can be easily retrofitted in the field.



WIPERS

The CC™ Actuator can be provided with a custom fitted wiper to prevent moisture and debris from entering the rod end opening of the outer tube. It is ideal for dirty, harsh, and wet environments.

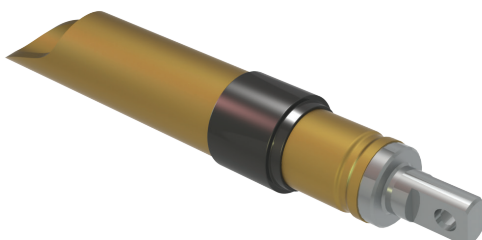

GEARBOXES

Part number CP-790-00

Right Angle Torque Capacity	150 in-lb
Thru Drive Torque Capacity	450 in-lb

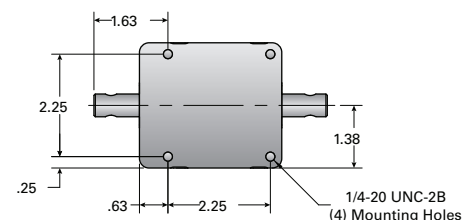
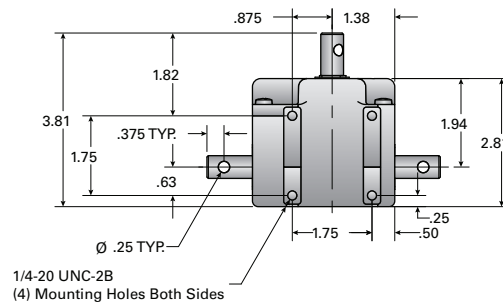
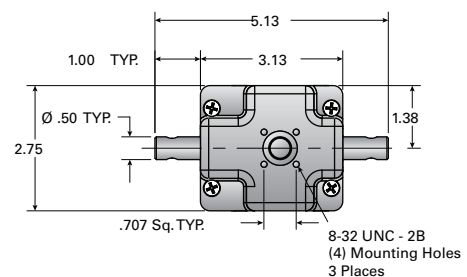
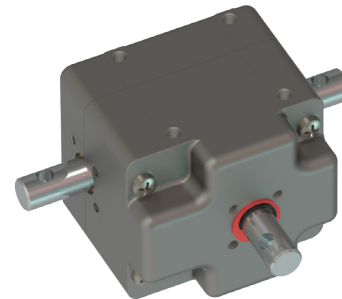

SENSOR OPTIONS

Nook/Thomson sensor options are used to provide input to counters, PLCs, or other control systems.

POTENTIOMETER

The 10K ohm potentiometer provides a varying resistance in proportion to the travel. Potentiometers offer absolute position feedback regardless of the loss of power.

HALL EFFECT

The hall effect sensor provides pulses at the rate of 40 per inch of travel.

REED SWITCH (OPTIONAL)

The reed switch provides contact closures at the rate of 40 per inch of travel. Contact Nook/Thomson Engineering for ordering details.

ENCODER

All resolutions stated are before quadrature decoding (example: 1,000 PPR \times 4 = 4,000 counts)

Pulses per Rev Options [PPR] : 48, 96, 100, 125, 196, 200, 250, 256, 384, 400, 500, 512, 800, 1,000, 1,024, 2,048.

Resolution: All resolutions stated are before quadrature decoding (example 1000 PPR \times 4 = 4000 counts)

3.6 VDC - 5.5 VDC; Max power consumption 10mA

Temp range: -40 - 100°C

Current consumption: 6mA (typ), 10mA max

10k Potentiometer

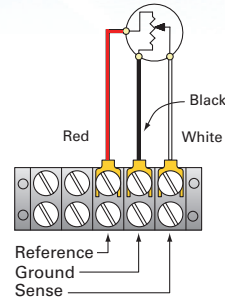

Hall Effect

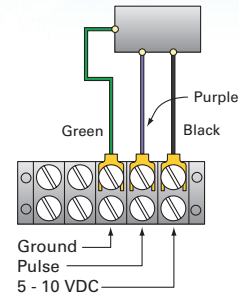

Reed Switch

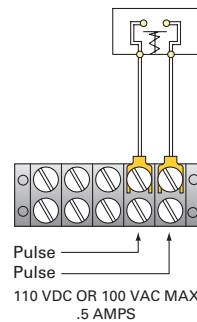

Encoder

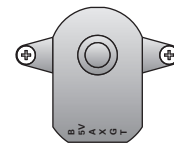

- B = B Channel
- 5V = +5 VDC Power
- A = A Channel
- X = Index Output
- G = Ground
- T = Unused

Actuators with 20" or less stroke, resolution is 500 ohms per inch of travel. Greater than 20" of stroke the resolution is 250 ohms per inch of travel.

MOTOR DIAGRAM

110 VAC ADAPTER

WITHOUT LIMIT SWITCH

WITH LIMIT SWITCH

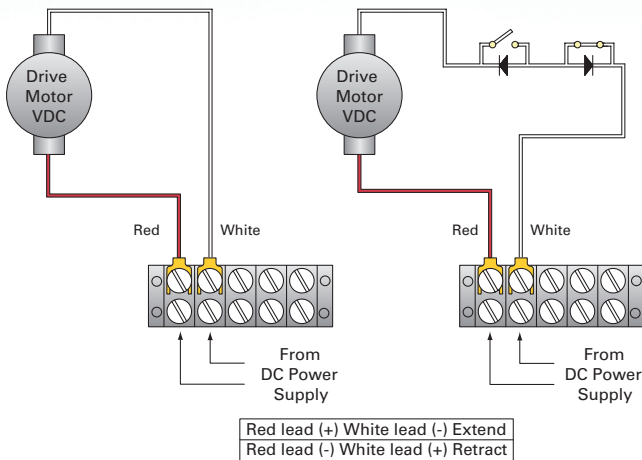

WITH RECTIFIER

When 110 VAC input voltage is required, a DC motor is supplied with a rectifier.

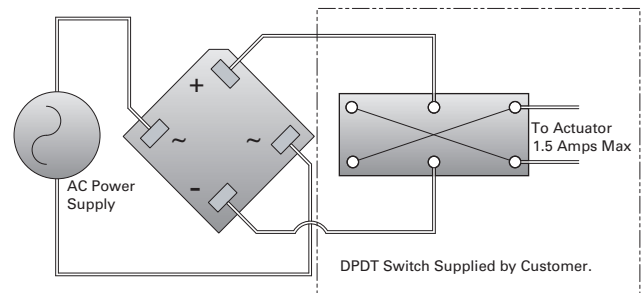

WITH DUAL LIMIT SWITCHES

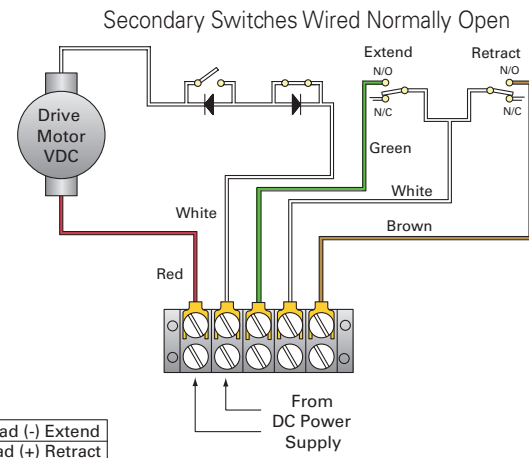
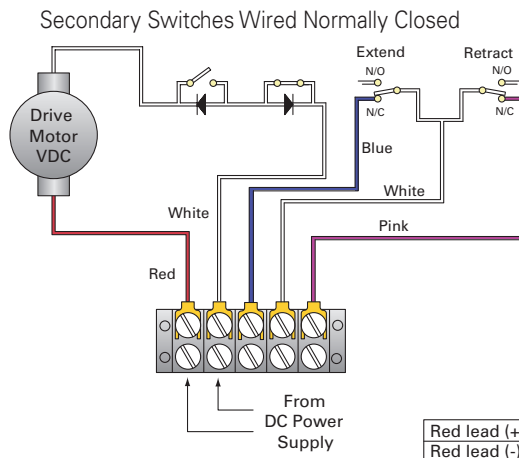

SETTING MOTOR LIMIT SWITCHES

Setting the Retracted Limit Switch

1. Drive the Actuator in the Retract direction with the lift rod unsecured from the load until the bottom limit switch is contacted.
2. Retract the lift rod by hand until it contacts the bottom stop.
3. Rotate one full rotation, allowing for approximately .200 over-travel.

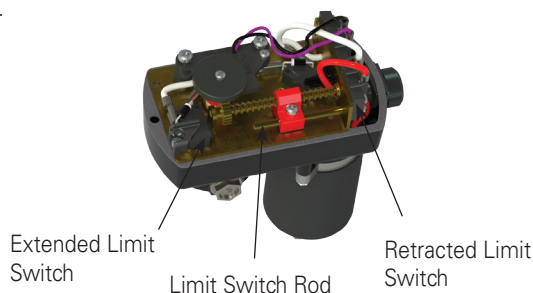

Setting the Extended Limit Switch

1. Drive the Actuator in the Extended direction until the desired limit is achieved.
2. Remove back cover.
3. Loosen the setscrew on the Limit Switch Rod.
4. Adjust the Limit Switch Rod until the Extended Switch is contacted.
5. Re-Tighten the setscrew.
6. Replace Cover.

PRECISION LINEAR ACTUATORS



Nook/Thomson Linear Actuators are used in many agricultural applications.



COMMERCIAL SERIES ACTUATORS

COMMERCIAL SERIES

ACTUATORS 124-141

VMD3 DC Actuaors 126-130

ND8 DC Actuators 131-135

NIA5 AC Actuators 136-141

VMD3 DC LINEAR ACTUATOR

The VMD3 Linear Actuator is completely self-contained and sealed for both indoor and outdoor use. It fits into small areas without sacrificing power or reliability. The load and length configurations of the VMD3 Linear Actuator cover a diverse range of intermittent applications requiring lifting, positioning, sorting, opening, clamping, and adjusting.

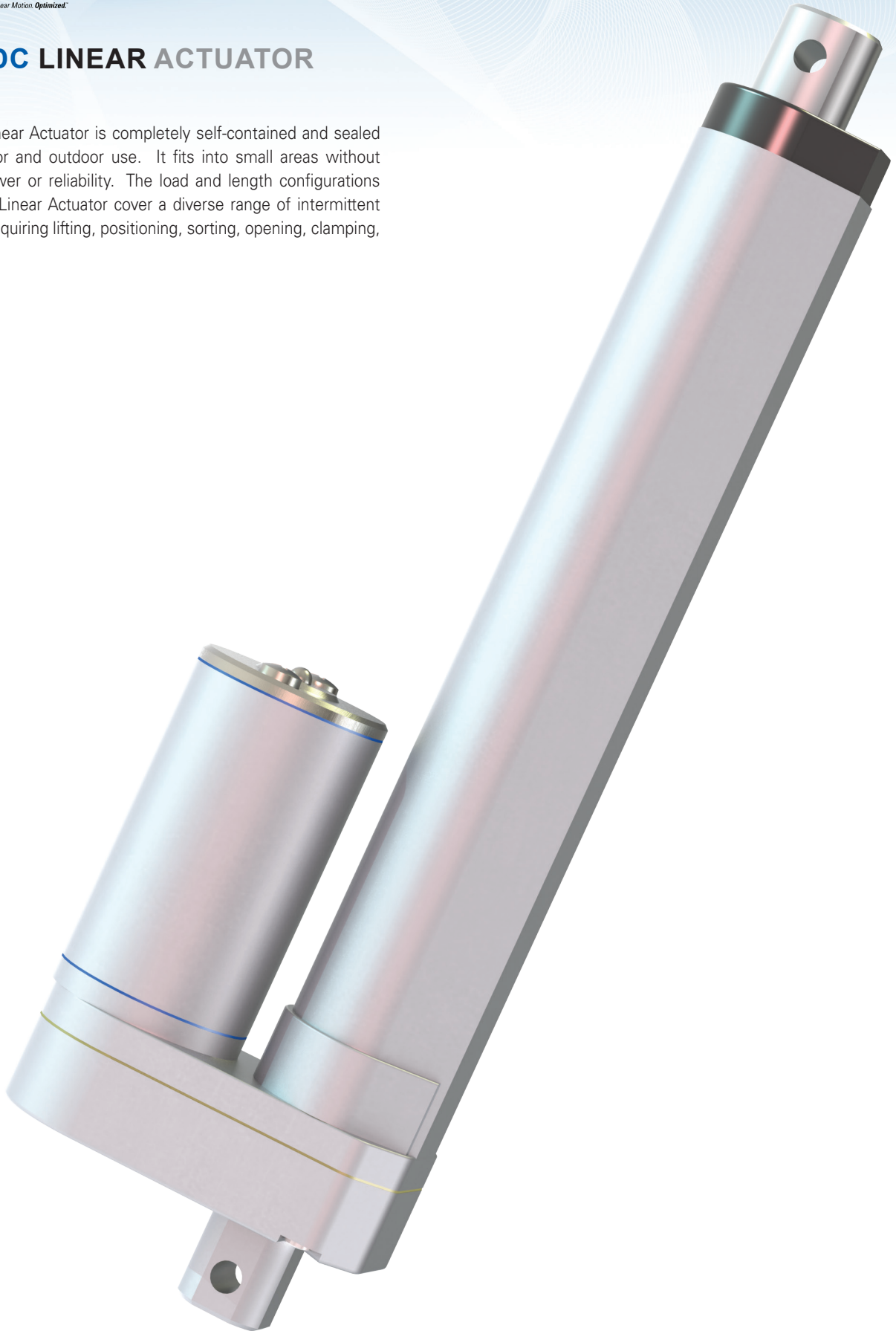

PART NUMBER SYSTEM

VMD3 - 12 - 20 - 200 - HS - IP65

SERIES VMD3 MODEL

VOLTAGE

- 12 = 12V DC
- 24 = 24V DC

GEAR RATIO

- 5 = 5:1
- 10 = 10:1
- 20 = 20:1
- 30 = 30:1
- 40 = 40:1

TRAVEL

- 50 = 50mm
- 100 = 100mm
- 150 = 150mm
- 200 = 200mm
- 250 = 250mm
- 300 = 300mm

OPTION

- HS = Hall Effect Sensor
- HS2 = Dual Hall Effect Sensors
- POT = Potentiometer

IP

- IP65 = IP65

TECHNICAL DATA

FEATURES:

- Aluminum Extension & Outer Tubes
- Clevis to Clevis mounting
- Travel: 50, 100, 150, 200, 250, 300mm
- Duty Cycle: 25%
- Environment: -26°C to + 65°C
- Preset Limit Switches
- Gear Ratios: 5:1, 10:1, 20:1, 30:1, 40:1
- IP65

OPTIONS:

- Potentiometer
- Hall Effect Sensor

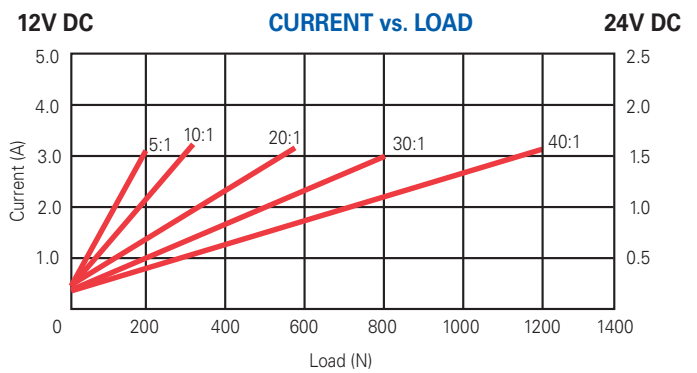
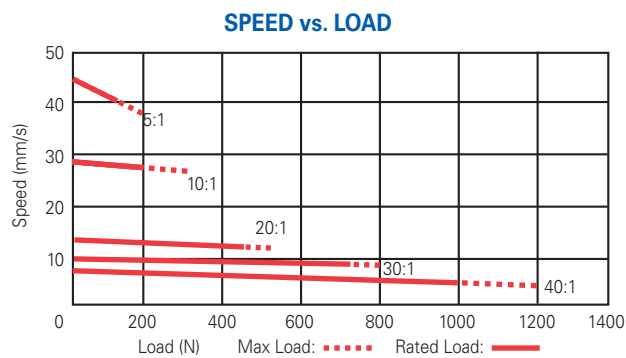

Nook/Thomson Linear Actuators are widely used in the medical industry.

COMMERCIAL SERIES ACTUATORS

VMD3 DC LINEAR ACTUATORS

STANDARD (REF)	2"	4"	6"	8"	10"	12"
Travel (mm)	50	100	150	200	250	300
Retracted Length (A)	158	209	260	311	362	413
Extended Length (A + stroke)	208	309	410	511	612	713

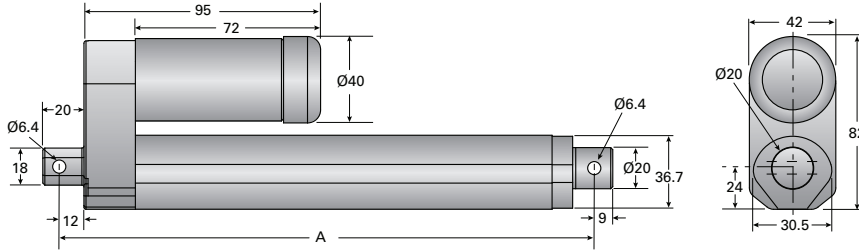

WITH POTENTIOMETER (REF)	2"	4"	6"	8"	10"	12"
Travel (mm)	50	100	150	200	250	300
Retracted Length (A)	195	246	297	348	399	450
Extended Length (A + stroke)	245	346	445	548	649	750

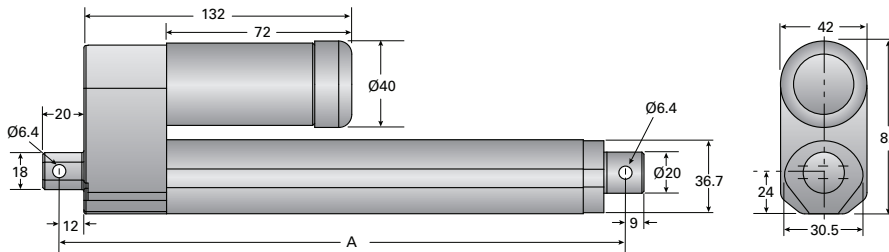

WITH HALL EFFECT (REF)	2"	4"	6"	8"	10"	12"
Travel (mm)	50	100	150	200	250	300
Retracted Length (A)	158	209	260	311	362	413
Extended Length (A + stroke)	208	309	410	511	612	713

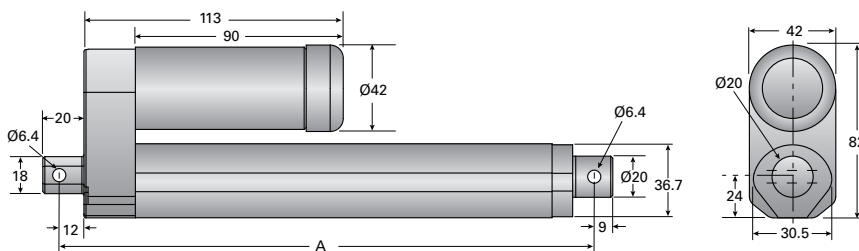

ND8 DC LINEAR ACTUATOR

The ND8 Linear Actuator is an economical, general purpose DC actuator designed for relatively light load applications. It comes equipped with either a ball screw or an acme screw. The ball screw version is equipped with a brake to prevent backdriving. Options are available including potentiometer and adjustable limit switches.



PART NUMBER SYSTEM

ND8 - 24 - 20 - A - 102 - POT - IP65

SERIES ND8 MODEL

VOLTAGE

12 = 12V DC
 24 = 24V DC

GEAR RATIO

Acme Screw Models

10 = 10:1
 20 = 20:1
 40 = 40:1

Ball Screw Models

5 = 5:1
 10 = 10:1
 20 = 20:1
 30 = 30:1
 40 = 40:1

SCREW

A = Acme Screw Model
 B = Ball Screw Model

TRAVEL

102 = 102mm
 153 = 153mm
 203 = 203mm
 254 = 254mm
 305 = 305mm
 457 = 457mm
 610 = 610mm

OPTION

LT = Limit Switch
 POT = Potentiometer
 Optional modified clevis angles. C0 is standard.

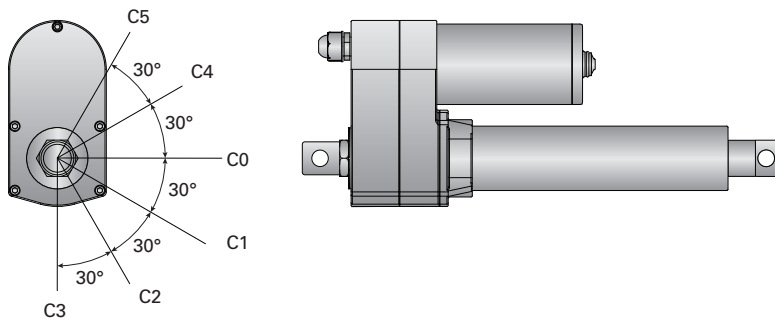

IP RATING

IP65 = IP65

SAMPLE PART NUMBERS

- ND8-12-5-B-152-LT-IP65
- ND8-24-20-A-158-LT-POT-IP65

TECHNICAL DATA

BALL SCREW SERIES



FEATURES:

- Stainless steel extension tube
- High efficiency ball screw
- Working temperature: -25° C to +65° C
- Static load capacity: 13600N
- Powder metallurgy gears
- No back driving
- Gear ratios: 5:1, 10:1, 20:1, 30:1, 40:1
- Overload protection by clutch
- Travel length: 100 - 600 mm
- Duty cycle: 25%
- IP65

OPTIONS:

- Potentiometer
- Adjustable limit switches
- Manual drive by hand crank
- Optional or customized front/rear mounting bracket

Note:

Manual Drive not available with Limit Switch or Potentiometer, only available with IP54, and 5:1, 10:1, or 20:1 ratios.

SPEED VS. LOAD

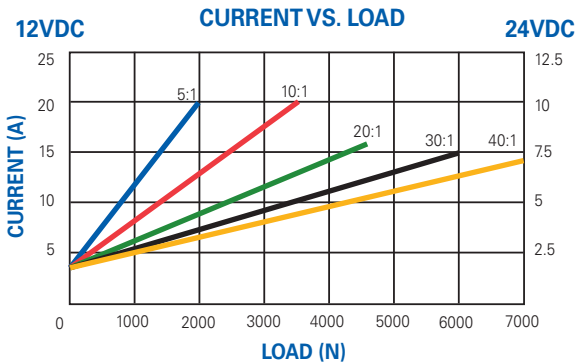
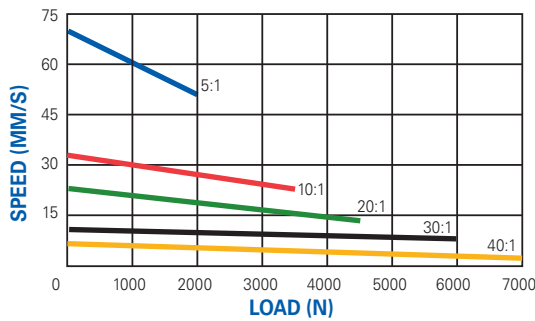

GEAR RATIO	MAX PUSH (N)	MAX PULL (N)	SPEED AT NO LOAD (mm/s)	SPEED AT FULL LOAD (mm/s)	STROKE (mm)	VOLTAGE (VDC)
5:1	2500	2500	67	47	102-610	12/24
10:1	3500	3500	33.5	26.7	102-610	12/24
20:1	4500	4500	17	14.3	102-610	12/24
30:1	6000	6000	11	10	102-610	12/24
40:1	7000	7000	8.4	7.4	102-610	12/24

COMMERCIAL SERIES ACTUATORS

NDS DC LINEAR ACTUATORS

STANDARD	4"	6"	8"	10"	12"	18"	24"
Travel (± 2.5 mm)	102	153	203	254	305	457	610
Retracted Length A (± 3.8 mm)	302	353	404	455	506	735	888

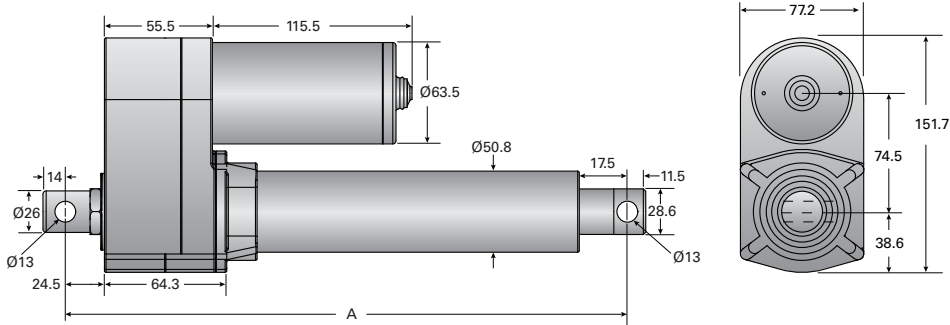

WITH POTENTIOMETER	4"	6"	8"	10"	12"	18"	24"
Travel (± 2.5 mm)	102	153	203	254	305	457	610
Retracted Length A (± 3.8 mm)	342	393	444	495	546	775	928

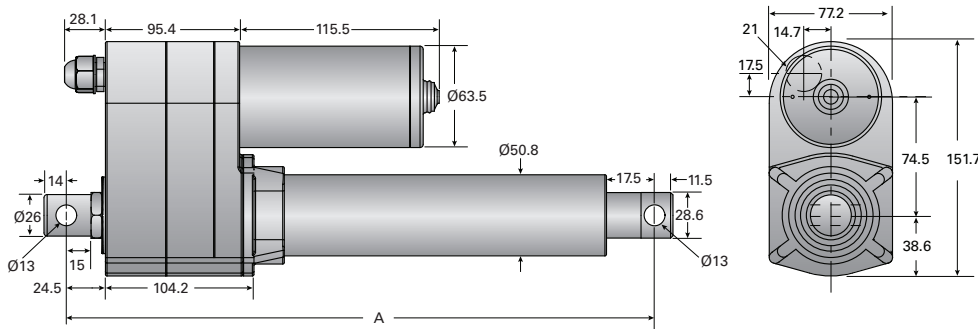

WITH LIMIT SWITCH*	4"	6"	8"	10"	12"	18"	24"
Travel (± 5 mm)	102	153	203	254	305	457	610
Retracted Length A (± 5 mm)	399	450	501	552	680	832	985

* with or without potentiometer

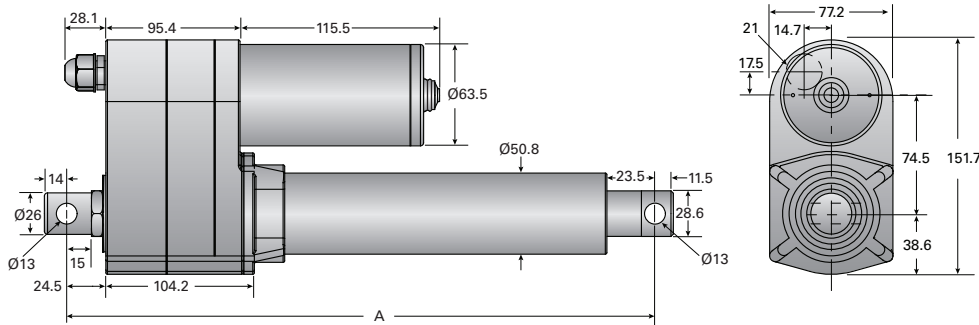

TECHNICAL DATA

ACME SCREW SERIES

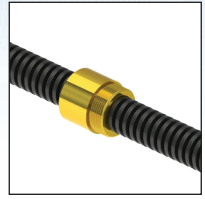

FEATURES:

- Steel Extension Tube
- Acme screw
- Working temperature: -25° C to +65° C
- Static load capacity: 4500N
- Powder metallurgy gears
- No back driving
- Gear Ratios: 10:1, 20:1, 40:1
- Overload protection by clutch
- Standard strokes: 102, 152, 203, 254, 305, 457, 610 mm
- Duty cycle: 25%
- IP65

OPTIONS:

- Potentiometer
- Adjustable limit switches
- Manual drive by hand crank
- Optional or customized front/rear mounting bracket

Note:

Manual Drive not available with Limit Switch or Potentiometer, only available with IP54, and 5:1, 10:1, or 20:1 ratios.

SPEED VS. LOAD

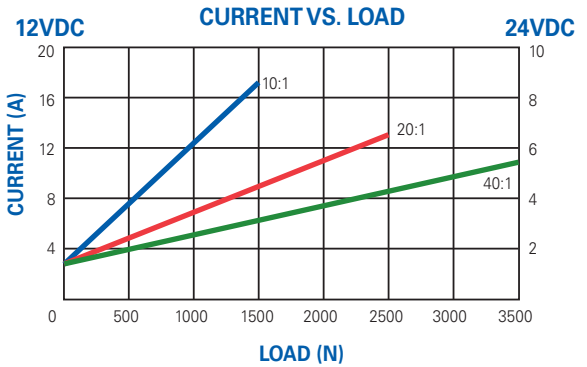
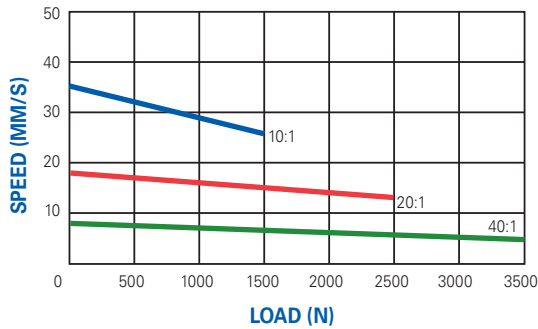

GEAR RATIO	MAX PUSH (N)	MAX PULL (N)	SPEED AT NO LOAD (mm/s)	SPEED AT FULL LOAD (mm/s)	STROKE (mm)	VOLTAGE (VDC)
10:1	1500	1500	33.5	26.7	102-610	12/24
20:1	2500	2500	17	14.3	102-610	12/24
40:1	3500	3500	8.4	7.4	102-610	12/24

COMMERCIAL SERIES ACTUATORS

NDS DC LINEAR ACTUATORS

STANDARD	4"	6"	8"	10"	12"	18"	24"
Travel (± 5 mm)	102	153	203	254	305	457	610
Retracted Length A (± 3.8 mm)	262	313	364	415	465	668	821

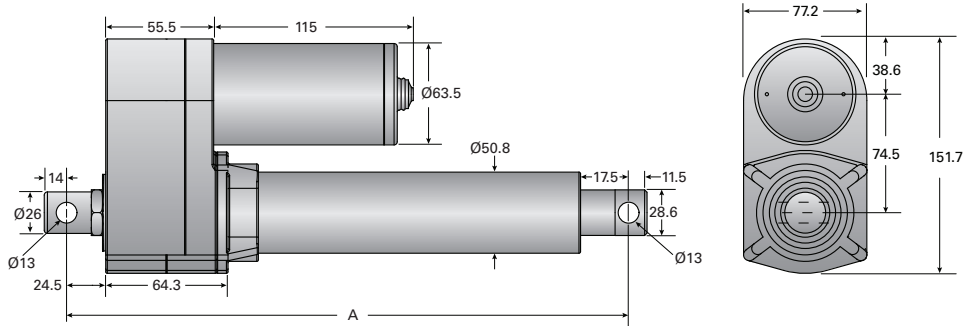

WITH POTENTIOMETER	4"	6"	8"	10"	12"	18"	24"
Travel (± 5 mm)	102	153	203	254	305	457	610
Retracted Length A (± 3.8 mm)	302	353	404	454	505	708	861

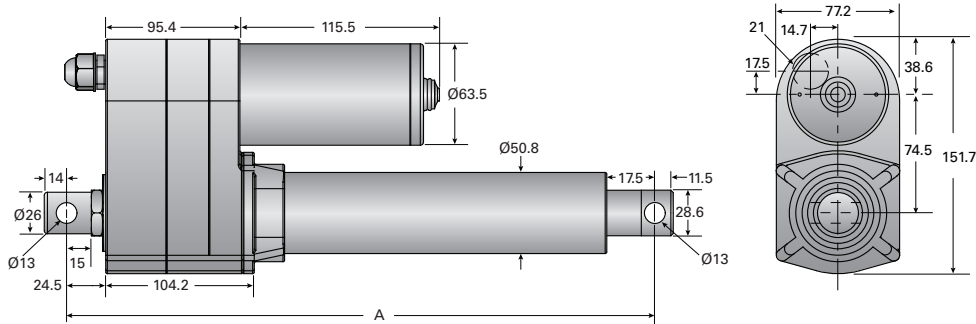

WITH LIMIT SWITCHES*	4"	6"	8"	10"	12"	18"	24"
Travel (± 5 mm)	102	153	203	254	305	457	610
Retracted Length A (± 3.8 mm)	359	410	460	511	613	765	918

* with or without potentiometer

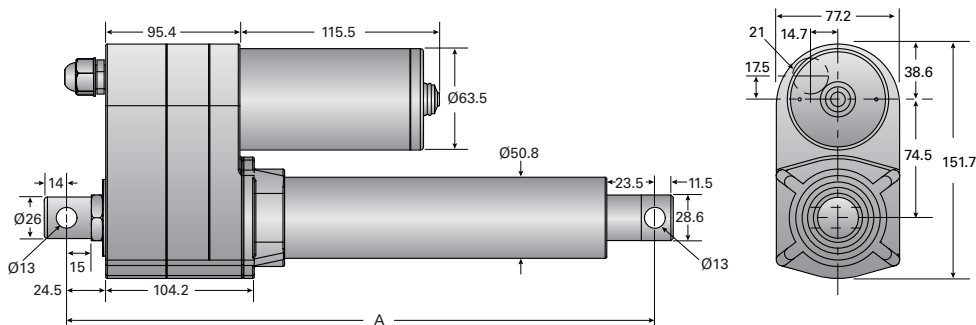

NIA5 AC LINEAR ACTUATOR

The NIA5 Linear Actuator is an economical, general purpose AC actuator designed for relatively light load applications. It is designed for intermittent duty applications and has a maximum load of 3500N. It comes equipped with either a ball screw or an acme screw. The ball screw version is equipped with a brake to prevent backdriving. Options are available including potentiometer and adjustable limit switches.



PART NUMBER SYSTEM

NIA5 - 230 - 20 - A - 102 - POT - IP65

SERIES NIA5 MODEL

VOLTAGE

230 = 230 VAC / 50 Hz
 115 = 115 VAC / 60 Hz

GEAR RATIO

Acme Screw Models

10 = 10:1
 20 = 20:1
 40 = 40:1

Ball Screw Models

5 = 5:1
 10 = 10:1
 20 = 20:1
 30 = 30:1
 40 = 40:1

SCREW

A = Acme Screw Model
 B = Ball Screw Model

TRAVEL

102 = 102mm
 153 = 153mm
 203 = 203mm
 305 = 305mm
 457 = 457mm
 610 = 610mm

OPTION

LT = Limit Switch
 POT = Potentiometer

Optional modified clevis angles. C0 is standard

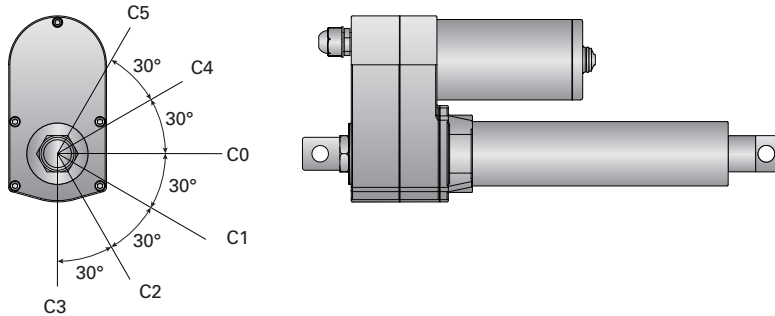

IP RATING

IP65 = IP65

SAMPLE PART NUMBERS

- NIA5-230-5-B-153-LT-IP65
- ND8-115-20-A-203-LT-POT-IP65

TECHNICAL DATA

BALL SCREW SERIES



FEATURES:

- Stainless Steel Extension Tube
- Working temperature: -25° C to +65° C
- Static load capacity: 13,600N
- Ball screw
- Powder metallurgy gears
- Aluminum alloy housing
- Overload protection by clutch
- Self-locking
- Thermal overload protection in the motor
- Gear Ratios: 5:1, 10:1, 20:1, 30:1, 40:1
- Duty cycle: 25%
- IP65

OPTIONS:

- Potentiometer
- Adjustable limit switches
- Optional or customized front/rear mounting bracket

115/230 VAC MOTOR

- Max Load: 7000N
- Max Speed: 56 mm/sec

Note:

Manual Drive not available.

115 VAC

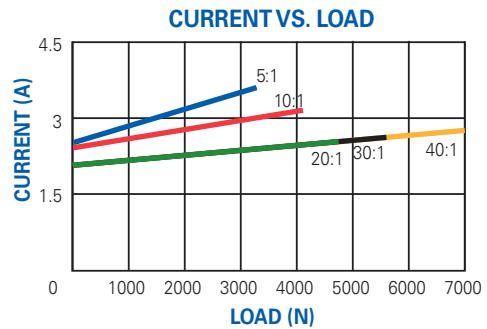
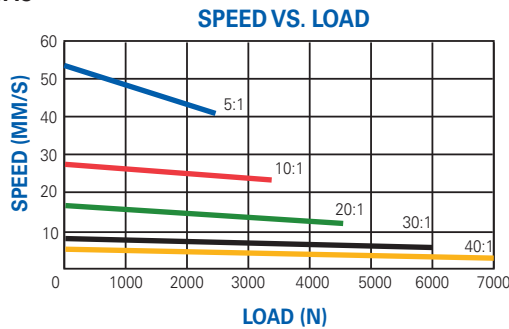

230 VAC

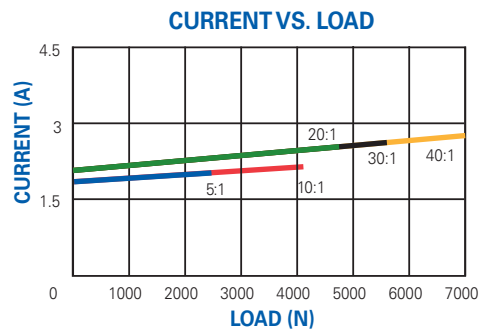
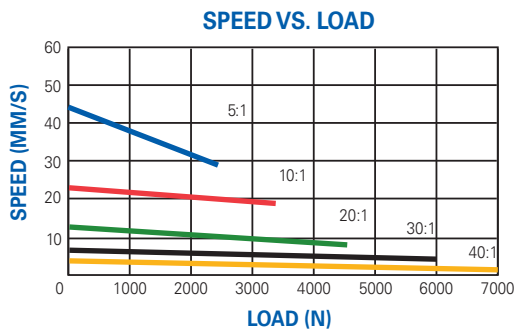

GEAR RATIO	MAX PUSH (N)	MAX PULL (N)	SPEED AT NO LOAD (mm/s)	SPEED AT FULL LOAD (mm/s)	STROKE (mm)	VOLTAGE (VAC)
5:1	2500	2500	52.8/43.5	40.8/29.0	102-610	115/230
10:1	3500	3500	26.5/21.8	22.9/17.5	102-610	115/230
20:1	4500	4500	13.1/10.8	11.8/9.3	102-610	115/230
30:1	6000	6000	8.7/7.2	7.9/3.6	102-610	115/230
40:1	7000	7000	6.6/5.4	6.0/4.9	102-610	115/230

COMMERCIAL SERIES ACTUATORS

NIA5 AC LINEAR ACTUATORS

STANDARD	4"	6"	8"	12"	18"	24"
Stroke (± 5 mm)	102	153	203	305	457	610
Retracted Length A (± 3.8 mm)	302	353	404	506	735	888

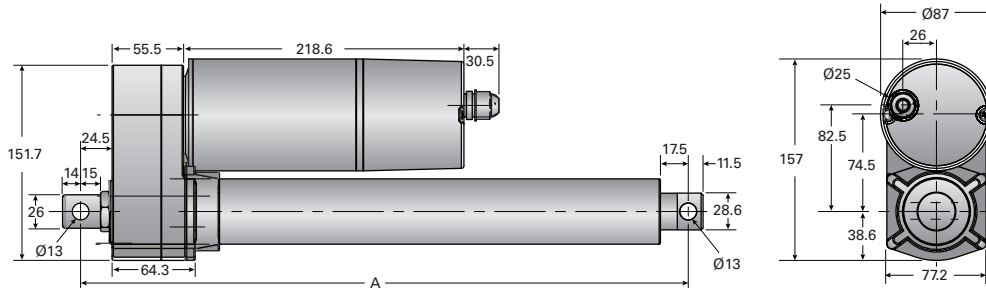

WITH POTENTIOMETER	4"	6"	8"	12"	18"	24"
Stroke (± 5 mm)	102	153	203	305	457	610
Retracted Length A (± 3.8 mm)	342	393	444	546	775	928

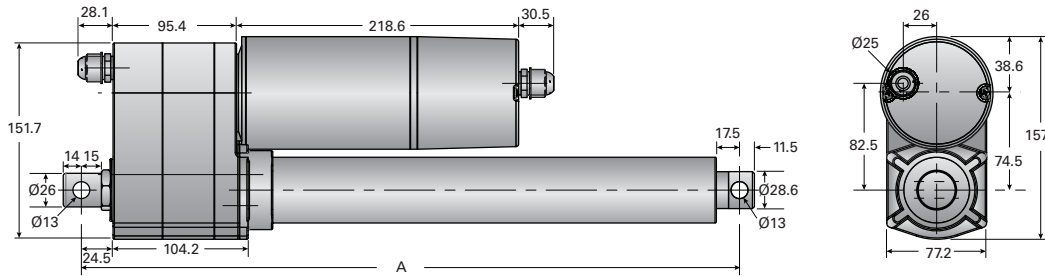

WITH LIMIT SWITCHES*	4"	6"	8"	12"	18"	24"
Stroke (± 5 mm)	102	153	203	305	457	610
Retracted Length A (± 3.8 mm)	399	450	501	680	832	985

* with or without potentiometer

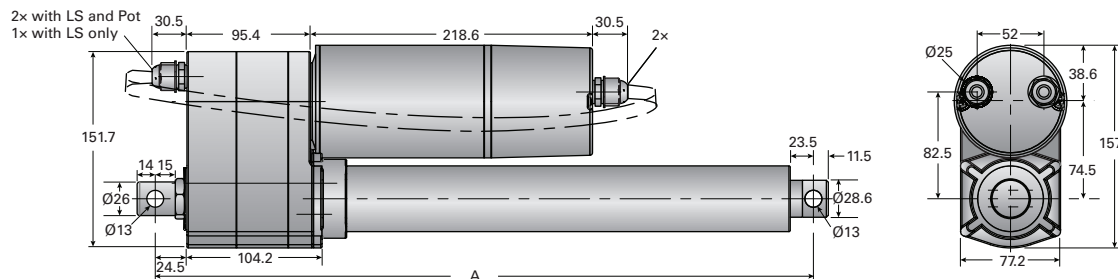

TECHNICAL DATA

ACME SCREW SERIES

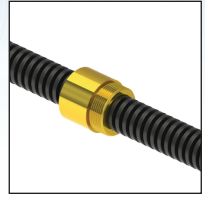

FEATURES:

- Steel Extension Tube
- Acme screw
- Working temperature: -25° C to +65° C
- Static load capacity: 4500N
- Powder metallurgy gears
- No back driving
- Gear Ratios: 10:1, 20:1, 40:1
- Overload protection by clutch
- Standard strokes: 102, 152, 203, 254, 305, 457, 610 mm
- Duty cycle: 25%
- IP65

OPTIONS:

- Potentiometer
- Adjustable limit switches
- Optional or customized front/rear mounting bracket

115/230 VAC MOTOR

- Max Load: 3500N
- Max Speed: 28 mm/sec

Note:

Manual Drive not available.

115 VAC

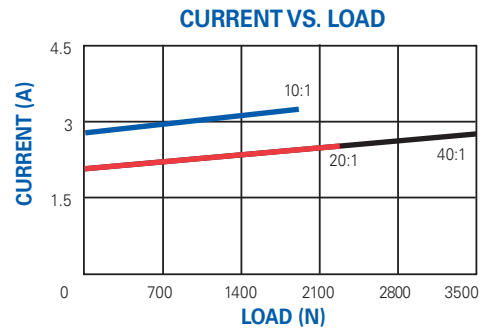
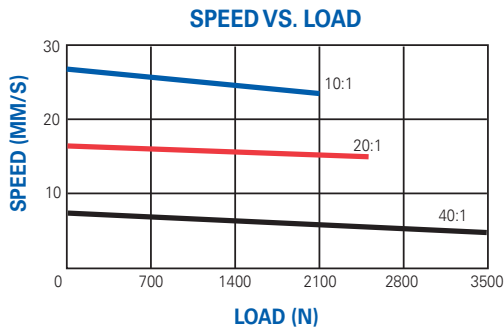

230 VAC

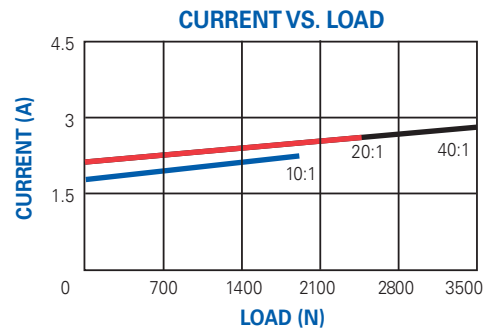
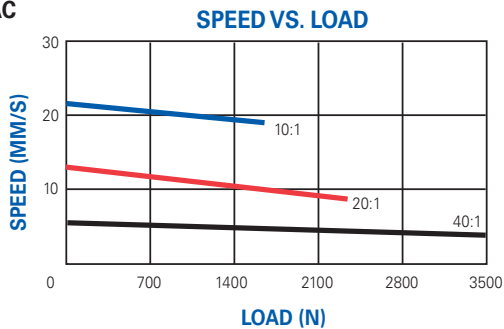

GEAR RATIO	MAX PUSH (N)	MAX PULL (N)	SPEED AT NO LOAD (mm/s)	SPEED AT FULL LOAD (mm/s)	STROKE (mm)	VOLTAGE (VAC)
10:1	1500	1500	26.5/21.8	22.9/17.5	102-610	115/230
20:1	2500	2500	13.1/10.8	11.8/9.3	102-610	115/230
40:1	3500	3500	6.6/5.4	6.0/4.9	102-610	115/230

COMMERCIAL SERIES ACTUATORS

NIA5 AC LINEAR ACTUATORS

STANDARD	4"	6"	8"	12"	18"	24"
Stroke ($\pm 5\text{mm}$)	102	153	203	305	457	610
Retracted Length A ($\pm 3.8\text{ mm}$)	262	313	364	465	668	821

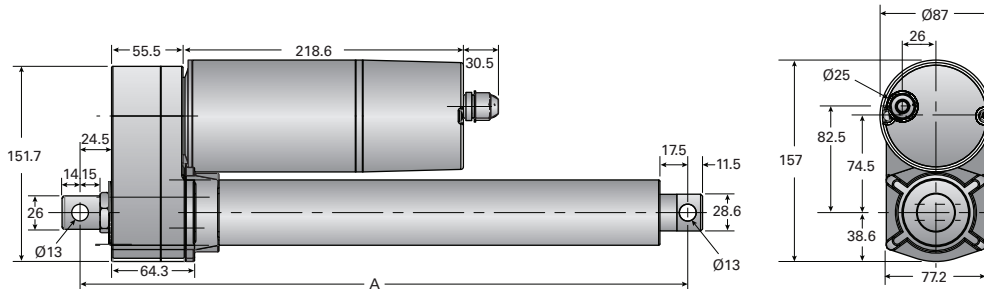

WITH POTENTIOMETER	4"	6"	8"	12"	18"	24"
Stroke ($\pm 5\text{mm}$)	102	153	203	305	457	610
Retracted Length A ($\pm 3.8\text{ mm}$)	302	353	404	505	708	861

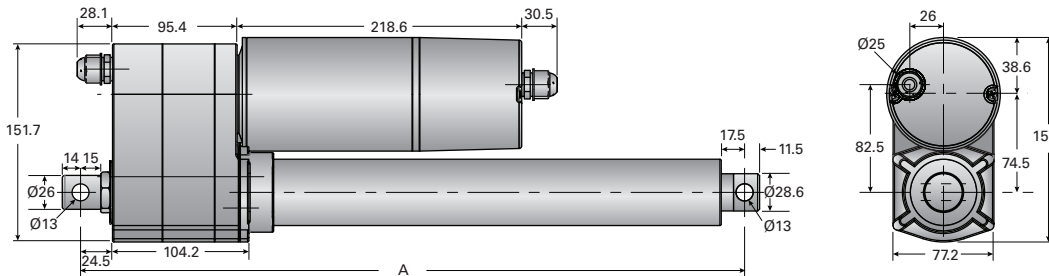

WITH LIMIT SWITCHES*	4"	6"	8"	12"	18"	24"
Stroke ($\pm 5\text{mm}$)	102	153	203	305	457	610
Retracted Length A ($\pm 3.8\text{ mm}$)	359	410	460	613	765	918

* with or without potentiometer

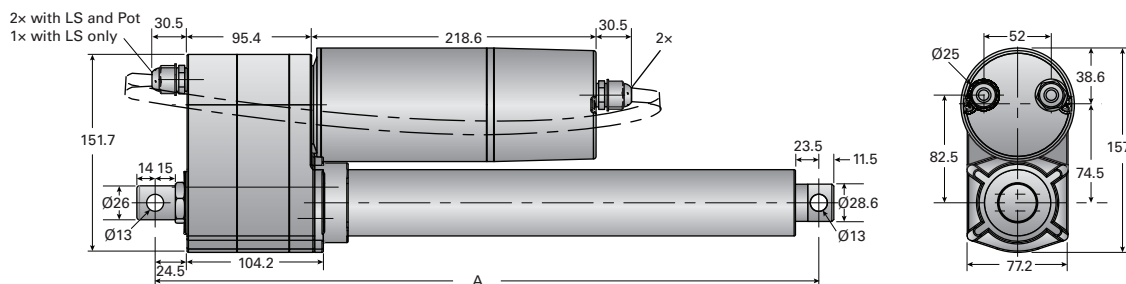

QUALITY

HISTORY

Since 1969, Nook Industries, Inc. has relentlessly and continuously developed the capabilities and skills to deliver products of the highest quality. Knowledge of testing and design, coupled with this experience working with stringent customer requirements in aerospace, medical, energy and military applications has provided the background to be a reliable partner.

HIGH TECH QUALITY EXPERIENCE

When you select Nook/Thomson as a supplier, you can be assured that your product will be designed and tested to rigorous product planning. Pre-design activity includes understanding of customer requirements applied to predictive models, engineering calculations and linear modeling through prototype development, stereo-lithography samples of form, fit, and function that verify design criteria.

VALIDATION AND VERIFICATION

Through many years of rigorous development, Nook/Thomson has proven its designs and manufacturing processes against the most stringent standards and specifications. Design and process verification and validation tools are employed throughout the product life cycle.

CERTIFICATIONS

Nook Industries, Inc. is certified to ISO-9001-2008 Internationally Recognized Quality System. Nook/Thomson also serves many customers in the Aerospace and Medical device markets and has complied with those Quality System Requirements as well.

ITAR

Nook/Thomson is registered with the Department Of State For International Traffic In Arms Compliance.



INSPECTION CAPABILITY

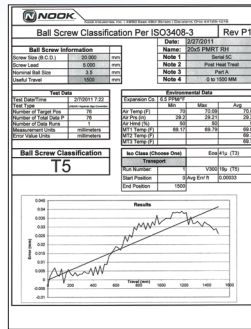

Laser Lead Measurement - Precise lead error gauging is utilized to validate processes to conform to Nook/Thomson internal specifications and customer requirements.

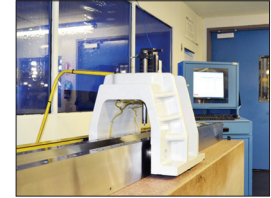

Zeiss Roundness Measurement - Critical to quality, characteristics such as roundness are monitored throughout the screw manufacturing process.

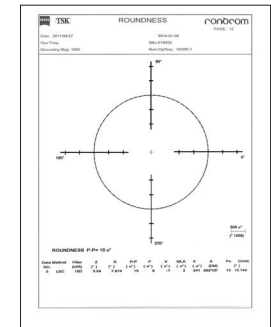

Zeiss Contour Readers - Prior to the start of any production run, thread form geometry is precisely measured to stringent engineering specifications.

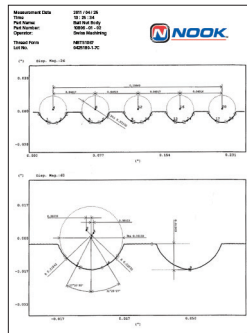
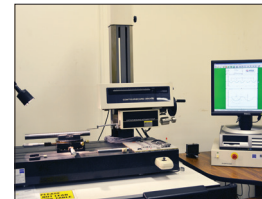

Metallurgical Lab - The metallurgical lab is capable of determining material composition from raw materials to final product. A micro hardness and case depth inspection is a routine check that validates the heat treat process.

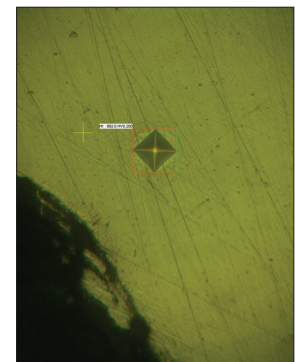

NOOK/THOMSON QUALITY EVOLUTION

DEVELOPED
MANUFACTURING
SYSTEMS

QUALITY SYSTEMS AND
ACCREDITATIONS

SUPPLY CHAIN APPROVAL
PROCESS

STATE OF THE ART
MANAGEMENT SYSTEMS

APQP LAUNCH
PROTOCOLS

SYSTEM AND PROCESS
PROTOCOLS

ENGINEERING ANALYSIS
AND PREDICTIVE TOOLS

CTQ/KPV ENGINEERING
SPECIFICATION
PROCESSES

RELIABILITY ENGINEERING
AND TESTING

DVP&R AND TEST
PLANNING

NOOK/THOMSON
DESIGNED AND BUILT
TEST MACHINES

CUSTOM ENGINEERED
AND BUILT TEST
INSTRUMENTATION

DESIGN AND TEST FOR
FAULT TOLERANCE AND
PROGNOSTICS

OVERLOAD/PROOF END OF
LINE TESTING

CERTIFICATION TESTING

QUALITY TOOLS:

- Design for Six Sigma manufacturing
- D.O.E. (Design of Experiments)
- APQP (Advanced Product Quality Planning)
- DFMEA, PFEMA
- FEA (Finite Element Analysis)
- DVP&R (Design Verification Plan & Report)
- Reliability Testing
- Process validation to 21 CFR Part 82 (Medical Device)

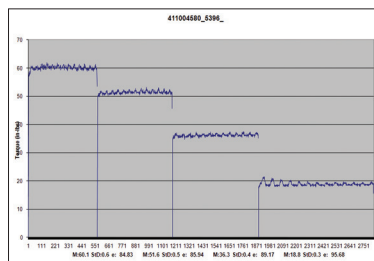

TESTING

Efficiency Measurement

Nook/Thomson Engineering has designed test machines to measure and validate screw assembly efficiency.

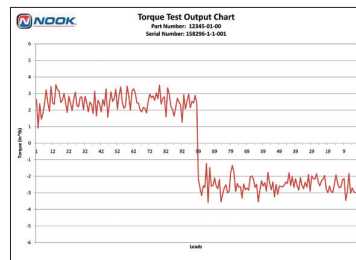
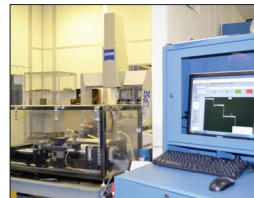

Torque Measurement - Preloaded ball screw assemblies are evaluated to determine compliance with engineering specifications utilizing a Dynamic Torque Testing Machine.



FUNCTIONAL TESTING

Nook/Thomson test systems and engineered testing processes perform analysis, verification, and solidification of life, durability, and performance. The functional testing defines operating limits in specifications and helps set defined targets in Product Launch Process and Assurance Plans.

The engineered testing provides predictive tools, generates data for prognostics, and validates performance wear models. Life tests help determine performance in multiple operating conditions as well. Nook/Thomson offers proof testing for customers developing new systems and actuators to help accelerate product release dates.



High Load Modular Test System
40,000 lb load - 100" CC



Convertible Test System
20,000 lb load - 100" CC



Also find us at:



Nook_Precision Linear_Actuators_CTEN-0014-01 | 20221028KB
Specifications are subject to change without notice. It is the responsibility of the product user to determine the suitability of this product for a specific application. All trademarks property of their respective owners. ©2022 Thomson Industries, Inc.

4950 East 49th Street | Cleveland, OH 44125-1016 USA | 216.271.7900 | toll-free: 800.321.7800 | f: 216.271.7020 | email: nook@nookind.com