

LINEAR MOTION PRODUCT GUIDE

ACME Screws



- Manufactured by thread rolling, milling, or grinding
- Centralizing thread forms for long lasting smooth, no-wedging performance

Ball Screws

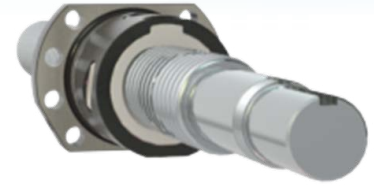

- Standard rolled, precision rolled, and ground screw accuracies
- Efficiently converts rotary motion to linear motion while maintaining high accuracy and repeatability

Precision Metric Ball Screws PMBS™



- Linear lead accuracy classes of T10, T7, T5, and T3
- Comply with ISO 3408 ball screw standard
- Precision ground preloaded and non-preloaded ball nuts
- Flanged, V-Threaded, and Cylindrical Keyed mounting options

Miniature Metric Ball Screws



- Designed for light load applications that deliver fast speed and close tolerance positioning

Roller Screws



- Used in the most demanding and precise linear motion applications
- Greater number of contact points a roller screw provides stiffness and higher load ratings compared to a ball screw

Bearing Supports



- Precision supports can be assembled to precision machined screws to provide a complete solution for any linear motion application

Ball Splines

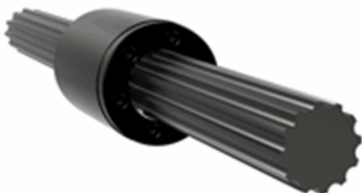

- Efficient, frictionless linear motion while transmitting torque
- Replace conventional splines due to reliability and high efficiency
- Recirculating bearing balls carry load between rotating (inner race) and rotating/sliding (outer race)



Linear Actuator Product Line

Worm Gear Screw Jacks



- Complete line of standard and custom ball and acme screw jacks from 1/4 to 100 tons
- Use individually or in multiple arrangements for a larger mechanical system

Modular Actuators



- Flexible positioning systems made of self-supporting and wear resistant aluminum profiles
- Used as single axis solution or assembled for a multitude of gantry XY and XYZ duties including inspection, pick-and-place, assembly or dispensing

NIA5 & ND8 DC Actuators



- Economical, general purpose DC actuators for light loads (Ball or Acme Screw) with intermittent duty and max. 7,000N load
- Ball screw version has ant-backlash brake, options include potentiometer and adjustable limit switches

CCTM Actuators



- High performance Ball or Acme screw linear actuators

Electric Cylinders

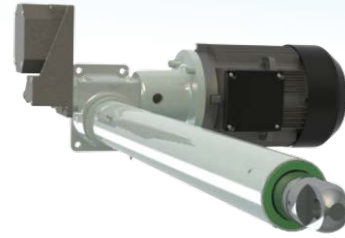

- Ruggedly designed in standard models with thrust capacities from 500 lbs. to 40,000 lbs.
- Single Reduction, Double Reduction, or In-Line Configurations
- Acme or ball screw drive (available for outdoor applications)

Programmable Actuators

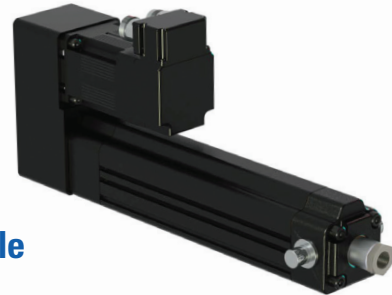

- Expanded range of performance, higher loads, longer life, increased duty cycles, higher speed and programmability
- Parallel and In-Line versions

VDM3™ Actuators



- Light duty 12/24V DC electric actuators for a wide variety of applications. 200N to 1,000N load capacity

Food Grade Actuators



- IP69K rated for hygienic washdown
- Smooth, stainless steel exterior
- Contamination resistant



Linear Actuator Product Line



Linear Motors

- NEMA 17 & 23 options
- Base and captive (enclosed) models
- Multiple sizes available



Drives & Controls

- Automation Technology and Controls (ATC) featuring integrated stepper motors, drives, controls, and power supplies. ATC also features servo motors.

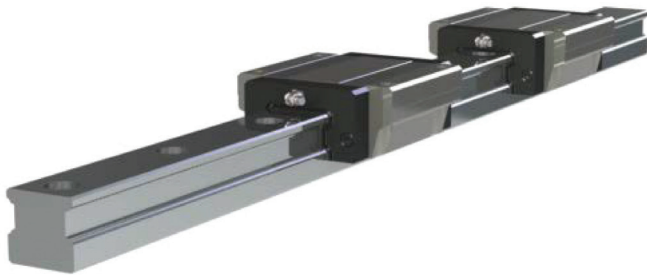

Profile Rails & Guides

- Stable and efficient linear guidance under variable speeds and high load conditions
- Offered in many sizes as well as Caged Ball Technology

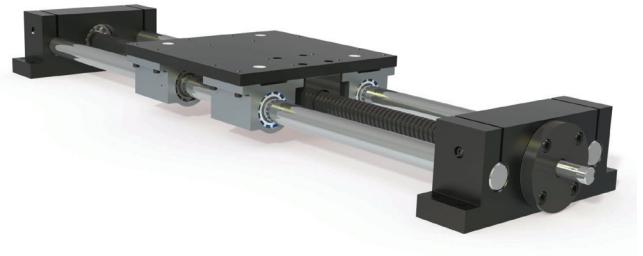

Linear Slides

- Matched components result in better system performance
- When used as sub-assemblies, set-up and alignment is reduced

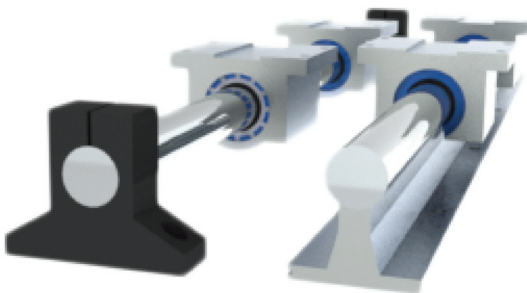

Linear Shafting, Bearings, & Pillow Blocks

- Hardened and ground shafting used for accurate, round hardened shaft and guide rod (Nook/Thomson can machine shafting)
- Full line of systems and components including solid shell LBB and self-aligning linear bearings, Pillow Blocks

Configurable Screw Assemblies

- Turn key solutions requiring only a power source (hand operation or motor).
- CAD drawings can easily be configured online.

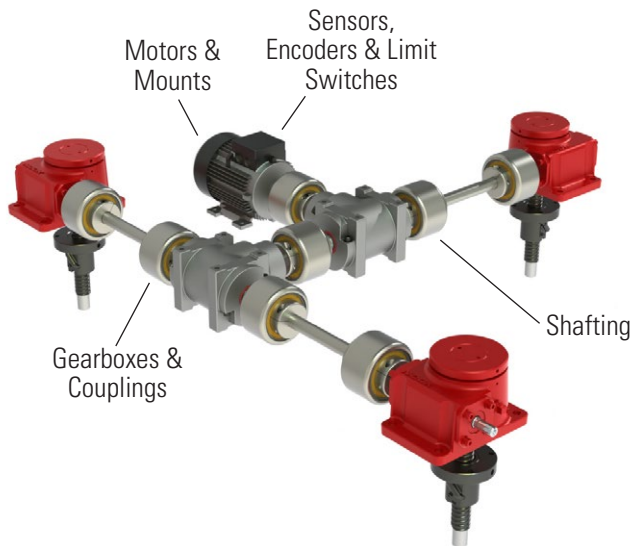
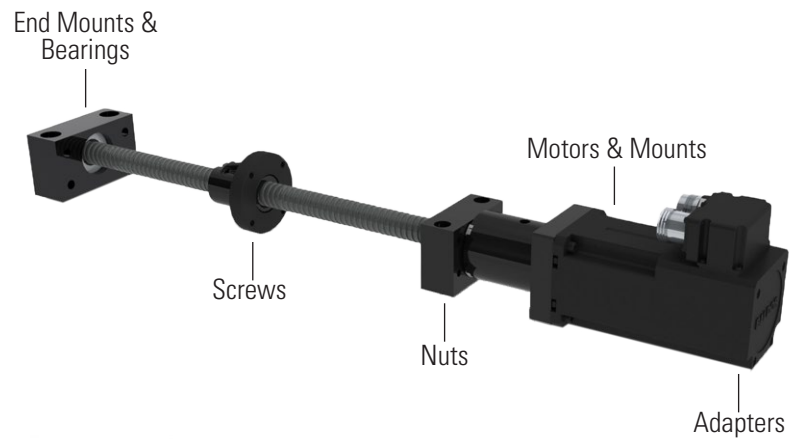

Configurable Actuator System

Nook/Thomson high-quality, high-performance actuator products can easily be configured into a multitude of different system arrangements.

Modular Linear Actuator Gantry Systems

- **Fit.** Can be manufactured in virtually any length.
- **Simplicity.** Pre-engineered to provide bidirectional movement across two or more planes.

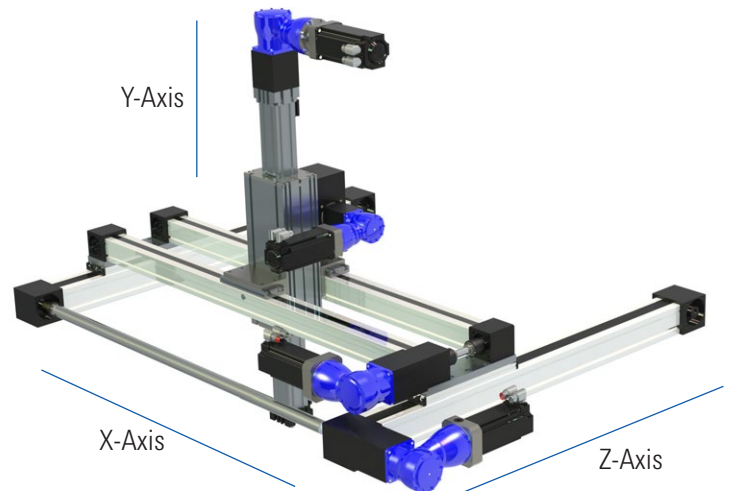

Design Support

Nook/Thomson provides outstanding technical support with dedicated subject matter experts and a variety of online tools to lower your development costs by simplifying the design process. We collaborate with customers to put your unique designs into motion by providing engineering expertise and state-of-the-art technology.



Applications Support

Collaborate with one of our technical experts on the specifics of your application for the ideal product fit that best meets your performance requirements and budget.



Design Support

Our team of proven, highly experienced design and application engineers can tailor a perfect solution to best fit your specifications, budget, and schedule.

Testing Services

We can help you design better products by simulating many real world scenarios to speed design, improve reliability, determine life cycle, and predict performance.

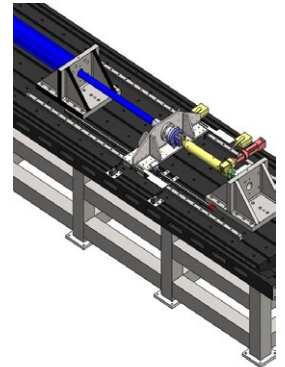

Industry Solutions

- Medical & Diagnostics
- Military & Defense
- Manufacturing
- Agriculture
- Food & Beverage
- Factory Automation
- Entertainment
- Machine Tool
- Aerospace
- Packaging
- Communications
- Transportation

And Many More...



Also find us at:



Nook_Product_Guide_BREN-0042-01 | 20220803SK
Specifications are subject to change without notice. It is the responsibility of the product user to determine the suitability of this product for a specific application. All trademarks property of their respective owners.
©2022 Thomson Industries, Inc.